

INDEX

S. NO.	TOPIC	PAGE. NO.
PART 1: BUSINESS MATHS		
CHAPTER 1	RATIO AND PROPORTION INDICES, LOGARITHMS	1.1 – 1.54
CHAPTER 2	EQUATION	2.1 – 2.28
CHAPTER 3	LINEAR INEQUALITIES	3.1 - 3.13
CHAPTER 4	TIME VALUE OF MONEY	4.1 – 4.57
CHAPTER 5	BASIC CONCEPTS OF PERMUTATIONS AND COMBINATIONS	5.1 – 5.31
CHAPTER 6	SEQUENCE AND SERIES – ARITHMETIC AND GEOMETRIC PROGRESSIONS	6.1 – 6.37
CHAPTER 7	SETS FUNCTIONS AND RELATIONS	7.1 – 7.28
CHAPTER 8	BASIC COMPONENTS OF DIFFERENTIAL AND INTEGRAL CALCULUS A- DIFFERENTIAL CALCULUS B- INTEGRAL CALCULUS	8.1 – 8.34

PART 2: LOGICAL REASONING

CHAPTER 9	NUMBER SERIES, CODING AND DECODING AND ODD MAN OUT	9.1 - 9.26
CHAPTER 10	DIRECTIONS TESTS	10.1 – 10.40
CHAPTER 11	SEATING ARRANGEMENTS	11.1 – 11.62
CHAPTER 12	BLOOD RELATIONS	12.1 – 12.30
PART 3 STATISTICS		
CHAPTER 13	STATISTICAL DESCRIPTIONS OF DATA	13.1 – 13.36
CHAPTER 14	MEASURES OF CENTRAL TENDENCY AND DISPERSION UNIT 1: MEASURES OF CENTRAL TENDENCY UNIT 2: DISPERSIONS	14.1 – 14.77
CHAPTER 15	PROBABILITY	15.1 – 15.41
CHAPTER 16	THEORETICAL DISTRIBUTIONS	16.1-16.32
CHAPTER 17	CORRELATIONS AND REGRESSION	17.1 – 17.35
CHAPTER 18	INDEXES NUMBER	18.1 – 18.31

CHAPTER - 1 RATIO AND PROPORTION, INDICES, LOGARITHMS



UNIT I: RATIO

TYPES OF RATIO

Continued ratio is the relation (or compass) between the magnitude of three or more Quantities of the same kind. The continued ratio of three similar quantities a, b, c is written as $a : b : c$

Similarly the triplicate ratio $a : b$ is $a^3 : b^3$.

The sub-duplicate ratio of $a : b$ is $a : b$ and the sub-triplicate ratio of $a : b$ is $a^{1/3} : b^{1/3}$

A ratio compounded of itself is called duplicate ratio $a^2 : b^2$ is the duplicate ratio of $a : b$

Continued ratio is the relation (or compass) between the magnitudes of three or more. Quantities of the same kind. the continued ratio of three similar quantities a, b, c is written as $a : b : c$

RATIO

A ratio is a comparison of the sizes of two or more

If a and b are two quantities of the same kind (in same units). Then the fraction a/b is called the ratio of a to b . it is written as $a : b$. Thus, the ratio of a to $b = a/b$ or $a : b$. The quantities a and b are called the terms of the ratio, a is called the first term or antecedent and b is called the second term or consequent

UNIT II: PROPORTIONS

MEANING	An equality of two ratios is called a proportion. Four quantities a, b, c, d are said to be in proportion if $a : b = c : d$.
TERMS OF PROPORTION	The quantities a, b, c, d are called terms of the proportion a, b, c, and d are called its first, second, third and fourth terms respectively. First and fourth terms are called extremes (or terms), second and third terms are called means (or middle term).

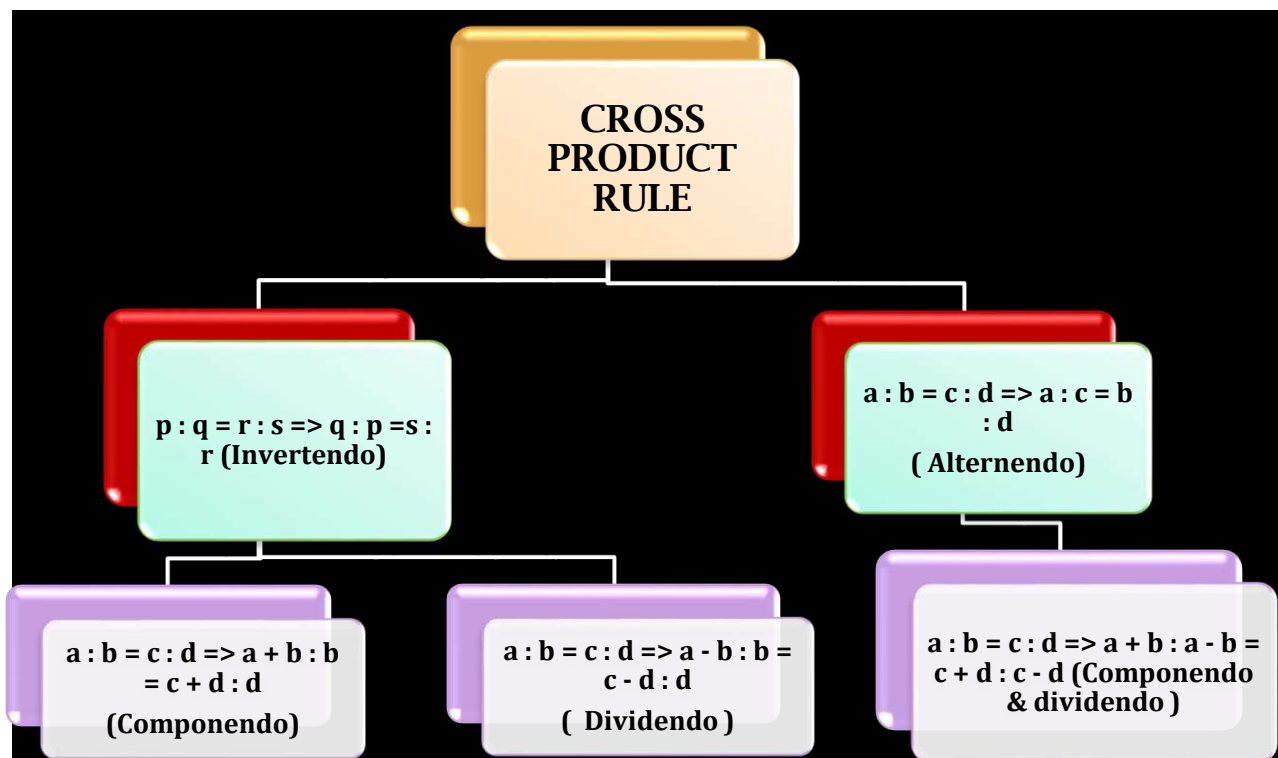

UNIT III : INDICES

PROPERTIES

This is called product rule.

Three quantities a, b, c of the same kind (in same units) are said to be in continuous proportion if $a : b = b : c$, i.e. $a/b = b/c$ i.e. $b^2 = ac$

If a, b, c is in continuous proportion, then the middle term b is called the mean proportion between a and c, a is the first proportional and c is the third proportion.

Thus, if b is mean proportional between a and c, then $b^2 = ac$ i.e. \sqrt{ac}

If $a : b = c : d$ then d is called fourth proportional.

If $a : b = c : d$ is in proportion then $a/b = c/d$ i.e. $ad = bc$

i.e. product of extreme = product of means.

Laws and Properties.

1.	$a^m \times a^n = a^{m+n}$, when m and n are positive integers (base must be same)
2.	$a^m/a^n = a^{m-n}$ when m and n are positive integers and $m > n$
3.	$(a^m)^n = a^{mn}$ where m and n are positive integers
4.	$(ab)^n = a^n \cdot b^n$ when n can take all of the values.
5.	$a^0 = 1$
6.	$a^{-m} = 1/a^m$ and $1/a^{-m} = a^m$

UNIT IV: LOGARITH

LOGARITHM.

- The two equations $ax = n$ and $x = \log_a n$ are only transformations of each other and should be remembered to change one form of the relation into the other.
- The logarithm of 1 to any base is zero. This is because any number raised to the power zero is one.
 - Since $a^0 = 1$, $\log_a 1 = 0$
- The logarithm of any quantity to the same base is unity. This is because any quantity raised to the power 1 is that quantity.
 - Since $a^1 = a$, $\log_a a = 1$

FUNDAMENTAL LAWS OF LOGARITHM

1.	$\log_a mn = \log_a m + \log_a n$
2.	$\log_a m/n = \log_a m - \log_a n$
3.	$\log_a m^n = n \log_a m$
4.	$\log_a a = 1, a = 1$
5.	$\log_a 1 = 0$

For more Info Visit - www.KITest.in

6.	$\log_b a \times \log_a b = 1$
7.	$\log_b a \times \log_c b = \log_c a$
8.	$\log_b a = \log a / \log b$
9.	$\log_b a = 1 / \log_a b$

**Question 1**

Ratio between 150 gm and 2 kg

- (a) 3: 40
 (b) 3: 41
 (c) 6: 12
 (d) None of these

Answer: A

Explanation:

Ratio between 150 gm and 2000 gm = $150/2000 = 3/40 = 3:40$

Question 2

a: b = c: d, then b: a = d: c

- (a) Alternendo
 (b) Dividend
 (c) Invertendo
 (d) Componendo

Answer: C

Explanation:

Invertendo properties of proportion is a: b = c: d then b: a = d: c

Question 3

The monthly incomes of two persons are in the ratio 4:5 and their monthly expenditure are in the ratio 7:9. If each save Rs. 50 per month, find their monthly incomes.

- (a) 600 and 100
 (b) 500 and 400
 (c) 900 and 700
 (d) 400 and 500

Answer: D

Explanation:

Let the monthly incomes of one person be Rs. 4x and that of the other be Rs. 5x

Let the monthly expenses of one person be 7y and that of other be 9y

According to the question,

$$4x - 7y = 50 \quad \dots\dots\dots (1)$$

$$5x - 9y = 50 \quad \dots\dots\dots (2)$$

On solving both equations, we get

$$Y = 50$$

$$X = 100$$

Therefore,

Monthly income of one person

$$= 4 \times 100 = 400$$

Monthly income for the other person

$$= 5 \times 100 = 500$$

So, the sum of their monthly incomes

$$= 400 + 500 = 900$$

Hence, the monthly incomes of the two persons are Rs. 4×100 and Rs. 5×100 i.e. Rs. 400 and Rs. 500.

Question 4

Shivani weighs 56.7 kg. If he reduces his weight in the ratio 7: 6, find his new weight.

(a) 486.96kg

(b) 48.6kg

(c) 486kg

(d) 4.86kg

Answer: B

Explanation:

Original weight of Shivani = 56.7 kg He reduces his weight in the ratio 7 : 6

$$\text{His new weight} = (6 \times 56.7) / 7 = 6 \times 8.1 = 48.6 \text{ kg}$$

Question 5

Find the value of x if 10/3: x = 5/2: 5/4

(a) 5/3

(b) 3/5

(c) 9/5

(d) 5/9

Answer: A

Explanation:

$$10/3 : x = 5/2 : 5/4$$

$$\text{Using cross product rule, } x \times 5/2 = (10/3) \times 5/4$$

$$\text{Or, } x = (10/3) \times (5/4) \times (2/5) = 5/3$$

Question 6

Find the third proportion to 2.4 kg, 9.6 kg.

(a) 384kg

(b) 38.4 kg

(c) 3804kg

(d) 3.84 kg

Answer: B

Explanation:

Let the third proportion to 2.4 kg, 9.6 kg be x kg. Then 2.4 kg, 9.6 kg and x kg are in continued proportion since

$$b^2 = ac \text{ so, } 2.4/9.6 = 9.6/x \text{ or, } x = (9.6 \times 9.6)/2.4 = 38.4$$

Question7

The inverse ratio of 11:15 is:

(a) 15: 11

(b) 11: 11

(c) 15: 15

(d) $\sqrt{11} : \sqrt{15}$

Answer: A

Explanation:

One ratio is the inverse of another if their product is 1. Thus a: b is the inverse of b: a and vice – versa.

Question8

If a: b = c: d = e: f =, then each of these ratios is equal

(a) $(a + c + e + \dots): (b + d + f + \dots)$ is equal to each ratio

(b) $(a + c + e + \dots): (b + d + f + \dots)$ is greater to each ratio

(c) $(a + c + e + \dots): (b + d + f + \dots)$ is zero ratio

(d) None

Answer: A

Explanation:

Due to addendo property.

Question9

If a: b = c: d = 2.5: 1.5, what are the values of ad: b c and a + c: b + d?

(a) ad: b c and a + c: b + d are 2:1 and 8:3

(b) ad: b c and a + c: b + d are 1: 1 and 5: 3

(c) ad: b c and a + c: b + d are 1:1 and 5: 5

(d) None.

Answer: B

Explanation:

In the given proportion a: b and c: d, applying cross product rule, we get
ad = bc

Dividing by bc on both sides, we get

$$\frac{ad}{bc} = 1$$

$$\frac{ad}{bc} = \frac{1}{1}$$

$$ad: bc = 1: 1$$

Given: a: b = c: d = 2.5: 1.5 ----- (1)

In the given proportion a: b and c: d applying the property addendo, we get

$$a : b = c : d = (a+b) : (c+d) \text{ ----- (2)}$$

From (1) and (2) we get

$$(a+b) : (c+d) = 2.5 : 1.5$$

$$(a+b) : (c+d) = (2.5 \times 10) : (1.5 \times 10)$$

$$(a+b) : (c+d) = 25 : 15$$

$$(a+b) : (c+d) = (25/5) : (15/5)$$

$$(a+b) : (c+d) = 5 : 3$$

Question10

Simplify $2x^{1/2} 3x^{-1}$ if $x = 4$

(a) 3

(b) 6

(c) 0.3

(d) 30

Answer: A

Explanation:

$$\text{We have } 2x^{1/2} 3x^{-1}$$

$$= 6x^{1/2} x^{-1} = 6x^{1/2-1}$$

$$= 6x^{-1/2}$$

$$= 3$$

Question11

Find the value of k form $(\sqrt{9})^{-7} \times (\sqrt{3})^{-5} = 3^k$

(a) 19/2

(b) 19/3

(c) -19/3

(d) -19/2

Answer: d

Explanation:

$$(\sqrt{9})^{-7} \times (\sqrt{3})^{-5} = 3^k$$

$$\Rightarrow \left\{ (3^2)^{1/2} \right\}^{-7} \left\{ (3)^{1/2} \right\}^{-5} = 3^k$$

$$\Rightarrow 3^{-7} \times 3^{-5/2} = 3^k$$

$$\Rightarrow 3^{-7\frac{-5}{2}} = 3^k$$

$$\Rightarrow 3^{\frac{-14-5}{2}} = 3^k$$

$$\Rightarrow 3^{\frac{-19}{2}} = 3^k$$

$$\Rightarrow k = \frac{-19}{2}$$

Question12

$\log_2 1 = ?$

(a) 0

(b) 1

(c) x

(d) m

Answer: A

Explanation:

According to properties of logarithm $\log_a 1 = 0$

Question13

log 6 +log 8 is expressed as

- (a) log 11 (b) log 48
(c) either a or b (d) log 14

Answer: B

Explanation:

According to properties of logarithm i.e., $\log_a m + \log_a n = \log_a mn$

Question14

A and B together have Rs. 1210. If $\frac{4}{15}$ of A's amount is equal to $\frac{2}{5}$ of B's amount, how much amount does B have?

- (a) Rs. 460 (b) Rs. 484
(c) Rs. 550 (d) Rs. 664

Answer: B

Explanation:

Rs484.

The logarithm of 16 to the base 2 is equal to 4

$$\frac{4}{15}A = \frac{2}{5}B$$

$$\rightarrow A = \left(\frac{2}{5} \times \frac{15}{4}\right)B$$

$$\rightarrow A = \frac{3}{2}B$$

$$\rightarrow \frac{A}{B} = \frac{3}{2}$$

$$A : B = 3 : 2$$

$$B's \text{ share} = Rs. \left[1210 \times \frac{2}{5}\right]$$

Question15

A sum of Rs. 312 was divided among 100 boys and girls in such a way that the boy gets Rs. 3.60 and each girl Rs. 2.40 the number of girls is

- (a) 35 (b) 40
(c) 45 (d) 50

Answer: B

Explanation:

Step (I): Let x be the numbers of boys and y be the number of girls.

Given total number of boys and girls = 100

$$X + y = 100 \text{ ----- (I)}$$

Step (ii): A boy gets Rs. 3.60 and a girl gets Rs. 2.40

The amount given to 100 boys and girls = Rs. 312

$$3.60x + 2.40y = 312 \text{ ----- (ii)}$$

Step (iii):

Solving (i) and (ii)

$$3.60x + 3.60y = 360 \text{ -----Multiply (I) by 3.60}$$

$$3.60x + 2.40y = 312 \text{ ----- (ii)}$$

$$1.20y = 48$$

$$Y = 48 / 1.20$$

$$= 40$$

→ Number of girls = 40

Question16

Two numbers are respectively 20% and 50% more than a third number. The ratio of the two numbers is:

(a) 2 : 5

(b) 3 : 5

(c) 4 : 5

(d) 6 : 7

Answer: C

Explanation:

Let the third number be x.

$$\text{Then, first number} = 120\% \text{ of } x = \frac{120x}{100} = \frac{6x}{5}$$

$$\text{Second number} = 150\% \text{ of } x = \frac{150x}{100} = \frac{3x}{2}$$

$$\text{Ratio of first two numbers} = \left(\frac{6x}{5} : \frac{3x}{2} \right) = 12x : 15x = 4 : 5.$$

Question17

Seats for mathematics, physics and biology in a school are in the ratio 5:7:8, There is a proposal to increase these seats by 40%, 50% and 75% respectively. What will be the ratio of increased seats?

(a) 2:3:4

(b) 6:7:8

(c) 6:8:9

(d) None of these

Answer: A

Explanation:

Originally, let the number of seats for mathematics, Physics and biology be 5x, 7x and 8x respectively.

Number of increased seats are (140% of 5x), (150% of 7x) and (175% of 8x)

$$\left(\frac{140}{100}x \times 5x \right), \left(\frac{150}{100}x \times 7x \right) \text{ and } \left(\frac{175}{100}x \times 8x \right)$$

$$7x, \frac{21x}{2} \text{ and } 14x$$

∴ The required ratio = $7x, \frac{21x}{2} : 14x$

→ $14x : 21x : 28x$

→ $2 : 3 : 4$

Question18

A sum of money is to be distributed among A, B, C and D in the proportion of 5: 2: 4: 3. If c gets Rs. 1000 more than D, what is B's share?

(a) Rs. 500

(b) Rs. 1500

(c) Rs. 2000

(d) None of these

Answer: C

Explanation:

Let the shares of A, B, C and D be Rs. $4x$ and $RS.3X$ Respectively.

Then, $4x - 3x = 1000$

→ $x = 1000.$

→ B's share = Rs. $2x = Rs. (2 \times 1000) = Rs. 2000.$

$\left(\frac{140}{100} \times \frac{x}{5x}\right), \left(\frac{150}{100} \times \frac{x}{7x}\right), \left(\frac{175}{100} \times \frac{x}{8x}\right)$

$7x, \frac{21x}{2}$ and $14x$

$14x : 21x : 28x$

$2:3:4$

Question19

Salaries of Ravi and Sumit are in the ratio 2:3. If the salary of each is increased by Rs. 4000, the new ratio between 40: 57. What is Sumit's salary?

(a) Rs. 17,000

(b) Rs. 20,000

(c) Rs. 25,500

(d) Rs. 38,000

Answer: D

Explanation:

Let the original salaries of Ravi and Sumit be Rs. $2x$ and Rs. $3x$ respectively.

Then $\frac{2x+4000}{3x+4000} = \frac{40}{57}$

→ $57(2x + 4000) = 40(3x + 4000)$

→ $6x = 68,000$

→ $3x = 34,000$

Sumit's present salary = $(3x + 4000) = Rs. (34000 + 4000) = Rs. 38,000.$

Question20

The ratio of the number of boys and girls in a college is 7:8. If the percentage increase in the number of boys and girls be 20% and 10% respectively, what will be the new ratio?

(a) 8: 9

(b) 17: 18

(c) 21: 22

(d) None

Answer: C**Explanation:**

Their increased number is (120% of 7x) and (110% of 8x).

Originally, let the number of boys and girls in the college be 7x and 8x respectively.

$$\left(\frac{120}{100} \times 7x\right) \text{ and } \left(\frac{110}{100} \times 8x\right)$$

$$\frac{42x}{5} \text{ and } \frac{44x}{5}$$

$$\text{The required ratio} = \left(\frac{42x}{5} : \frac{44x}{5}\right) = 21:22$$

Question21**If 0.75: x=5: 8, then x is equal to:**

(a) 1.12

(b) 1.2

(c) 1.25

(d) 1.30

Answer: B**Explanation:**

$$0.75: x :: 5: 8$$

$$\Rightarrow \frac{0.75}{x} = \frac{5}{8}$$

$$\Rightarrow x = 0.75 \times \frac{8}{5}$$

$$\Rightarrow 1.2$$

Question22**The sum of three numbers is 98. If the ratio of the first to second is 2:3 and that of the second to the third is 5:8, then the second number is:**

(a) 20

(b) 30

(c) 48

(d) 58

Answer: B**Explanation:**

Let the three parts be A, B, C, Then,

$$A: B = 2: 3 \text{ and } B: C = 5: 8 = \left[5 \times \frac{3}{5}\right] : \left[8 \times \frac{3}{5}\right] 3: \frac{24}{5}$$

$$\Rightarrow A: B: C = 2:3: \frac{24}{5} = 10: 15: 24$$

$$\Rightarrow B = \left[98 \times \frac{15}{49}\right] = 30$$

Question23**If Rs. 782 be divided into three parts, proportional to $\frac{1}{2} : \frac{2}{3} : \frac{3}{4}$, then the first part is:**

a) Rs. 182

b) Rs. 190

c) Rs. 196

d) Rs. 204

Answer: D

Explanation:

Given ratio = $\frac{1}{2} : \frac{2}{3} : \frac{3}{4}$, = 6:8: 9 Multiplying by 12

$$1^{\text{st}} \text{ part} = \text{Rs.} \left[782 \times \frac{6}{23} \right]$$

$$= \text{Rs.} 204$$

Question24

The salaries A, B, C are in the ratio 2:3:5. If the increments of 15%, 10% and 20% are allowed respectively in their salaries, then what will be new ratio of their salaries?

- (a) 3:3: 10 (b) 10:11: 20
 (c) 23:33: 60 (d) None of these

Answer: C**Explanation:**

Let A = 2k, B = 3k and C = 5k.

$$A's \text{ new } \frac{115}{100} \text{ of } 2k = \left(\frac{115}{100} \times 2k \right) = \frac{23k}{10}$$

$$B's \text{ new } \frac{110}{100} \text{ of } 3k = \left(\frac{110}{100} \times 3k \right) = \frac{33k}{10}$$

$$\left(\frac{110}{100} \times 5k \right) \frac{120}{100} \text{ of } 5k = \left(\frac{120}{100} \times 5k \right) = 6K$$

$$\text{New ratio } \left(\frac{23k}{10} : \frac{33k}{10} : 6k \right)$$

$$= 23: 33: 60$$

Question25

If 40% of a number is equal to two-third of another number, what is the ratio of first number the second number?

- (a) 2: 5 (b) 3:4
 (c) 5: 3 (d) 7: 3

Answer: C**Explanation:**

$$\text{Let } 40\% \text{ of } A = \frac{2}{3} B$$

$$\text{Then, } \frac{40A}{100} = \frac{2B}{3}$$

$$\rightarrow \frac{2A}{5} = \frac{2B}{3}$$

$$\rightarrow \frac{A}{B} = \left(\frac{2}{3} \times \frac{5}{2} \right) = \frac{5}{3}$$

$$A: B = 5: 3$$

Question26**The fourth proportional to 5, 8, 15 is:**

- (a) 18 (b) 24
(c) 19 (d) 20

Answer: b**Explanation:**

Let the fourth proportional to 5, 8, 15 be x.

Then, 5:8:15: x

$$\rightarrow 5x = (8 \times 15)$$

$$X = \frac{(8 \times 15)}{5} = 24$$

View Answer Discuss in forum workspace Report

Question27**Two number are in the ratio 3: 5. If 9 is subtracted from each, the new numbers are in the ratio 12:23. The smaller number is:**

- (a) 27 (b) 33
(c) 49 (d) 55

Answer: B**Explanation:**

Let the numbers be 3x and 5x.

$$\text{Then, } \frac{3x-9}{5x-9} = \frac{12}{23}$$

$$\rightarrow 23(3x-9) = 12(5x-9)$$

$$\rightarrow 9x = 99$$

$$\rightarrow x = 11$$

The smaller number = $(3 \times 11) = 33$ **Question28****In a bag, there are coins of 25 p, 10 p and 5 p in the ratio of 1:2: 3. If there is Rs. 30 in all, how many 5 p coins are there?**

- (a) 50 (b) 100
(c) 150 (d) 200

Answer: C**Explanation:**

Let the number of 25 p, 10 p and 5 p coins be x, 2x, 3x respectively.

$$\text{Then, sum of their values} = \text{Rs. } \left[\frac{25x}{100} + \frac{10 \times 2x}{100} + \frac{5 \times 3x}{100} \right]$$

$$\therefore \frac{60x}{100} = 30 \rightarrow \frac{30 \times 100}{60} = 50$$

Hence, the number of 5 p coins = $(3 \times 50) = 150$ **Question29**

$a^{\log b - \log c} \cdot b^{\log c - \log a} \cdot c^{\log a - \log b}$ has a value of

- (a) 1 (b) 0
(c) -1 (d) None

Answer: A

Explanation:

$$\text{Let } x = a^{\log b - \log c} \cdot b^{\log c - \log a} \cdot c^{\log a - \log b}$$

Taking log both the sides, we get

$$\log x = \log (a^{\log b - \log c} \cdot b^{\log c - \log a} \cdot c^{\log a - \log b})$$

$$= \log a^{\log b - \log c} + \log b^{\log c - \log a} + \log c^{\log a - \log b}$$

$$= (\log b - \log c) \log a + (\log c - \log a) \log b + (\log a - \log b) \log c$$

$$= 0$$

$$\log x = 0$$

$$\Rightarrow x = e^0$$

$$\Rightarrow 1$$

Question30

If $\log a = \frac{1}{2} \log b = \frac{1}{5} \log c$, the value of $a^4 b^3 c^{-2}$ is

- (a) 1 (b) 0
(c) -1 (d) None

Answer: A

Explanation:

$$\text{Let } \log a = \frac{1}{2} \log b = \frac{1}{5} \log c = k$$

$$\text{Then } \log a = k \Rightarrow a = e^k$$

$$\frac{1}{2} \log b = k \Rightarrow \log b = 2k$$

$$\Rightarrow b = e^{2k}$$

$$\frac{1}{5} \log c = k \Rightarrow \log c = 5k$$

$$\Rightarrow c = e^{5k}$$

$$a^4 b^3 c^{-2} = e^{4k} \cdot e^{6k} \cdot e^{-10k}$$

$$= e^0 = 1$$

Question31

The ratio of market prices of wheat and paddy is 2:3 and the ratio of quantities consumed in a family is 5:4. Find the ratio expenditure of wheat and paddy.

- (a) 6:5 (b) 5:6
(c) 1:1 (d) 8:15

Answer: B

Explanation:

$$\text{Expenditure} = \text{Price} \times \text{Quantity}$$

$$\frac{\text{Wheat price}}{\text{paddy price}} = \frac{2}{3} \text{ and } \frac{\text{Wheat quantity consumed}}{\text{paddy quantity consumed}} = \frac{5}{4}$$

Multiplying both ratios

$$\text{Wheat price} \times \text{Wheat quantity consumed} = 2 \times 5$$

$$\text{Paddy price} \times \text{paddy quantity consumed} = 3 \times 4$$

$$\frac{\text{Wheat Expenditure}}{\text{paddy Expenditure}} = \frac{5}{6}$$

Question32

If A: B = 2:3, B:C = 4:5 and C: D = 6:7, then find the value of A: B:C:D

(a) 15:24:30:35

(b) 16:24:30:35

(c) 17:24:30:35

(d) 18:24:30:35

Answer: B

Explanation:

Given a: b = 2: 3, b: c = 4: 5, c: d = 6: 7

$$a: b = 2 \times 8: 3 \times 8 = 16: 24$$

$$b: c = 4 \times 6: 5 \times 6 = 24: 30$$

$$c: d = 6 \times 5: 7 \times 5 = 30: 35$$

So, a: b: c: d = 16: 24: 30: 35

Question33

The value of $\log_2 (\log_5 625)$ is:

(a) 2

b) 5

(c) 10

(d) 15

Answer: A

Explanation:

Let $\log_5 625 = x$.

Then, $5^x = 625 = 5^4$ or $x = 4$

Let $\log_2 4 = y$ or $2^y = 4 = 2^2$ or $y = 2$

$\log_2 (\log_5 625) = 2$

Question34

In a library, the ratio of number of story books to that of non - story books was 4:3 and total number of story books was 1248. When some more story books were bought, the ratio became 5:3. Find the number of story books bought.

(a) 312

(b) 321

(c) 936

(d) 1560

Answer: A

Explanation:

Given

The total number of story books in a library is 1248 when the ratio of the number of story books of that of non-story books was 4 : 3

To find:

The number of story books bought.

Solution:

The given ratio of the number of story books to that of non-story books was 4 : 3 when the total number of story books in a library is 1248.

Let $4x$ be the total number of storybooks.

$$\Rightarrow 4x = 1248$$

$$\Rightarrow X = \frac{1248}{4} = 312$$

The number of non-story books = $3x = 3 \times 312 = 936$

When some more story books were bought the ratio becomes 5 : 3

Let y no of storybooks added to the library

$$\Rightarrow \frac{(1248+y)}{936} = \frac{5}{3}$$

$$\Rightarrow 1248+y = \frac{(5 \times 936)}{3}$$

$$\Rightarrow 1248 + y = 1560$$

$$\Rightarrow Y = 1560 - 1248$$

$$\Rightarrow Y = 312$$

\therefore 312 more books were bought and added to the library.

Question35

Log144 is equal to:

(a) $2\log 4 + 2\log 2$

(b) $4 \log 2 + 2\log 3$

(c) $3\log 2 + 4\log 3$

(d) $3 \log 2 \times 4\log 3$

Answer: B

Explanation:

Log 144

$\log (2^4 \times 3^2)$

$\log 2^4 + \log 3^2$

$4 \log 2 + 2\log 3$

Question36

Price of each article of type P, Q AND R is Rs. 300, Rs. 180 and Rs. 12

Respectively. Suresh buys articles of each type in the ratio 3:2:3 in Rs. 6480.

How many articles of type Q did he purchase?

(a) 8

(b) 14

(c) 20

(d) None of the above

Answer: A

Explanation:

Let the common factor be k.

Hence, the number of articles of type P, Q and R will be 3k, 2k and 3k respectively

Also,

Unit price of article x Number of articles = Total amount for the articles

$$300 \times 3k + 180 \times 2k + 120 \times 3k = 6480$$

$$K = 4$$

$$\text{Number of articles of type Q} = 2k = 8$$

Question37

Ajay and Raj together have Rs. 1050. On taking Rs. 150 from Ajay will have same amount as what Raj had earlier. Find the ratio of amounts with Ajay and Raj initially.

(a) 3:4

(b) 7:1

(c) 1:3

(d) 4:3

Answer: D

Explanation:

Let initially money with Ajay be A and with Raj be R

$$\text{So, } A + R = 1050 \quad \dots\dots\dots (1)$$

Also, money is taken from Ajay, so

$$A - 150 = R$$

$$A - R = 150 \quad \dots\dots\dots (2)$$

Adding both equations

$$2A = 1200$$

$$A = \text{Rs. } 600 = \text{Initial money with Ajay}$$

$$R = 1050 - 600 = \text{Rs. } 450 = \text{Initial money with Raj}$$

$$\frac{\text{Amount with Ajay}}{\text{Amount with Raj}} = \frac{600}{450} = \frac{4}{3}$$

Question38

The three numbers are in the ratio $\frac{1}{2} : \frac{2}{3} : \frac{3}{4}$. The difference between greatest and smallest numbers is 36. Find the numbers.

(a) 72, 84, 108

(b) 60, 72, 96

(c) 72, 84, 96

(d) 72, 96, 108

Answer: A

Explanation:

Let the common factor be k

$$\text{So the three numbers are } \frac{k}{2}, \frac{2k}{3}, \frac{3k}{4}$$

Also, we know that, greatest - smallest = 36

$$\frac{3k}{4} - \frac{k}{2} = 36$$

$$K = 144$$

$$\text{The numbers are } \frac{k}{2} = \frac{144}{2} = 72$$

$$\frac{2k}{2} = \frac{2 \times 144}{2} = 84 : \frac{3k}{4} = \frac{3 \times 144}{4} = 108$$

Question39

If $\log_3 y = 100$ and $\log_3 x = 10$, then the value of y is:

- (a) 3^{10} (b) 3^{100}
 (c) 3^{1000} (d) 3^{10000}

Answer:C

Explanation:

$$\log_3 x = 10$$

$$\text{Hence, } x = 3^{10}$$

$$\log_x y = 100$$

$$y = x^{100} = (3^{10})^{100} = y = 3^{1000}$$

Question40

The third proportional between $a^2 - b^2$ and $(a + b)^2$ is

- (a) $\frac{a+b}{a-b}$ (b) $\frac{a-b}{a+b}$
 (c) $\frac{(a+b)^3}{a-b}$ (d) $\frac{(a+b)^3}{(a-b)^3}$

Answer: C

Explanation:

Let x be required third proportional, then

$$(a^2 - b^2):(a + b)^2 :: (a + b)^2 : x$$

$$\rightarrow \frac{a^2 - b^2}{(a+b)^2} = \frac{(a+b)^2}{x}$$

$$\rightarrow x(a^2 - b^2) = (a + b)^4 \text{ i.e. } x(a - b)(a + b) = (a + b)^4$$

$$\rightarrow x = \frac{(a+b)^3}{a-b}$$

Question41

A sum of Rs. 53 is divided in such a way that A gets Rs. 7 more than what b gets and b gets Rs. 8 more than what C gets. The ratio of their share is.

- (a) 25:18:10 (b) 25:18:1
 (c) 2:18:10 (d) 25:8:10

Answer: A

Explanation:

Let the share of c = Rs. X.

Then share of B = Rs. $(x+8)$ and share of A = Rs. $(x + 8 +7)$

Therefore $x + (x+8) + (x+15) = 53$

→ $3x = 30$ i.e. $x = 10$

Hence ratio

A: B: C = 25:18: 10

Question42

Fourth proportion to 4, 6, 8 is:

(a) 12

(b) 32

(c) 48

(d) None

Answer: A

Explanation:

Let x be the required fourth proportional. Then 4,6,8, x are in proportion.

$4: 6 :: 8:x$ or $4/6, 8/x$

$= 4x = 48$

$X = 12$

Question43

The mean proportion between 64 and 81 is

(a) 72

b) 62

(c) 48

d) None

Answer: A

Explanation:

Let x be the mean proportional then $64:x:: x: 81$

→ $\frac{64}{x} = \frac{x}{81}$

→ $x^2 = 5184$

→ $x = 72$

Question44

The ratio of numbers of girls and boys participating in sports of a school is 4:5. If the number of girls is 212, determine the number of boys participating in the sports.

(a) 256

(b) 265

(c) 251

(d) 263

Answer: b

Explanation:

Let the number of girls $4x$

But number of girls 212

So,

$4x = 212$

$x = \frac{212}{4}$

$x = 53 \dots (1)$
 number of boys = $5x$
 put the value of x
 $= 5 \times 53 = 265$

Question45

Income ratio of Ramesh and Suresh is 5:6. Their spending ratio is 7:9, Ramesh saves 4000 and Suresh saves 3000. Income and spending respectively of Ramesh and Suresh are

- (a) Ramesh – 25000, 21000, Suresh – 30000, 27000
 (b) Ramesh – 36000, 32000; Suresh - 30000,27000
 (c) Ramesh – 30000, 27000;
 (d) None of the above

Answer: A**Explanation:**

Income ratio = Ramesh: Suresh = $5:6 = \frac{5}{6}$;

Common factor helps in finding actual values easily

So, Take 'A' as common factor

Income of Ramesh = $5A$: Income of Suresh = $6A$

$\frac{\text{Spending of ramesh}}{\text{spending of Suresh}} = \frac{\text{Ramesh income}}{\text{Suresh income}} = \frac{7}{9}$

$\frac{5A - 4000}{6A - 3000} = \frac{7}{9}$

$\frac{5A - 4000}{6A - 3000} = \frac{7}{9}$

$9(5A - 4000) = 7(6A - 3000)$

$A = 5000$

Income of Ramesh = $5A = 25000$;

Income of Suresh = $6A = 30000$

Spending of Ramesh = $25000 - 4000 = 21000$

Spending of Suresh = $30000 - 3000 = 27000$

Ramesh – 25000, 21000; Suresh – 30000, 27000

Question46

Find A: B: C: D when A: B = 2:3; B:C = 7:9; C:D = 5:7

- (a) 70:105:135: 189
 (b) 105:115:236: 189
 (c) 70:124:155: 201
 (d) 12:78:256: 189

Answer: A**Explanation:**

A: B = 2:3; B:C = 7:9; C:D = 5:7

$a = 2$

$b = 3$

$c = 7$

$$d = 9$$

$$e = 5$$

$$f = 7$$

$$A : B : C : D = [2 \times 7 \times 5] : [3 \times 9 \times 5] : [3 \times 9 \times 7]$$

$$A : B : C : D = 70 : 105 : 135 : 189$$

Question47

Find the mean proportional between 7 and 63?

(a) 35

(b) 21

(c) 27

(d) 30

Answer: B**Explanation:**

In a : b : c, mean proportion = b

a : b : c can be written as a : b :: b : c

$$a : b :: b : c = \frac{a}{b} = \frac{b}{c} = b^2 = ac$$

Here, a = 7; c = 63

$$b = \sqrt{7 \times 63} = 21$$

Question48

It was intended that Rs. 585 be divided among P, Q and R in the ratio of 4:3:2 , but by mistake the distribution was made in the proportion of 1/4 : 1/3 : 1/2. How much does 'R' gain by the error?

(a) Rs. 99

(b) Rs. 126

(c) Rs. 140

(d) Rs. 152

Answer: C**Explanation:**

Total amount = Rs. 585

On dividing it in the ratio of 4:3: 2

$$\text{Share of P} = \frac{4}{9} * 585 = \text{Rs. 260}$$

$$\text{Share of Q} = \frac{3}{9} * 585 = \text{Rs. 195}$$

$$\text{Share of R} = \frac{2}{9} * 585 = \text{Rs. 130}$$

But the amount has been divided in the proportion of 1/4: 1/3: 1/2 i.e. 3: 4: 6

$$\text{Share of P} = \frac{3}{13} * 585 = \text{Rs. 135}$$

$$\text{Share of Q} = \frac{4}{13} * 585 = \text{Rs. 180}$$

$$\text{Share of R} = \frac{6}{13} * 585 = \text{Rs. 270}$$

Therefore, gain for R By Virtue of error = Rs. 270 – Rs. 130 = Rs. 140

Question49

By giving Rs. 50 to M, A would have the amount equal to what M had earlier. If the sum of the amounts with A and M is Rs. 650. What is the ratio of the amount with A to that with M earlier?

- (a) 7 : 4 (b) 5 : 3
(c) 2 : 1 (d) 7 : 6

Answer: D

Explanation:

Let the amounts with A and M be Rs. "x" and Rs. "y" respectively.

Thus, we have, $x + y = 650$

$$X - 50 = y$$

$$X - y = 50.$$

Hence, $x = 350$ & $y = 300$

Thus the required ratio is $350: 300 = 7: 6$

Question50

A housewife wishes to purchase three articles A, B and C from a sum of Rs. 200. The unit prices of the articles A, B and C are Rs.20 Rs. 35 and Rs. 25 respectively. If she spends the entire amount by purchasing 5 numbers of articles of type C, what is the ratio of the number of articles purchased of type A to that of type, B?

- (a) 1 : 2 (b) 2 : 1
(c) 1 : 1 (d) None of these

Answer: B

Explanation:

After spending Rs. 125 ($25 * 5$) for article of type C, the housewife is left with Rs. 75($200-125$). Since this amount has to be spent in totality, she must have purchased 2 articles of type A equivalent to Rs. 40) and 1 article of type B (equivalent to Rs. 35) Thus, the required ratio is 2: 1.

Question51

In what ratio should the profit be divided if M, N, O invests capital in ratio 2:3:5 and their timing of their investments are in the ratio 4:5:6.

- (a) 8:15:30 (b) 5:18:28
(c) 4:5:6 (d) 2:3:5

Answer: A

Explanation:

$$P1:P2: P3 = (2*4): (3*5): (5*6) \\ = 8:15: 30$$

Question52

If a flat costs Rs. 4500per sq. ft., and a commercial space costs Rs. 9500 per sq. ft., then what is the ratio of their areas if the total cost of both are the same?

- (a) 9:19 (b) 19:9
(c) 15:28 (d) 28:15

Answer: B

Explanation:

Let A_1 be the area of flat and A_2 be that of the commercial space

Total cost = area * rate

Therefore, cost of flat = $A_1 * 4500$; cost of commercial space = $A_2 * 9500$

Both the above costs are same

$$A_1 * 4500 = A_2 * 9500$$

$$A_1 : A_2 = 9500 : 4500 = 19 : 9$$

Question53

In what ratio should the profit of Rs. 8000 be divided if x starts a business with an investment of Rs. 20000, y invests Rs. 7500 for 4 months and z invests Rs. 15000 after 3 months from the start of the business?

(a) 16:2:3

(b) 8:3:6

(c) 16:2:9

(d) 6:9:1

Answer: C

Explanation:

Let the profit of x be P_1 , that of Y be P_2 and of Z be P_3 .

$$P_1 : P_2 : P_3 = 20000 * 12 : 7500 * 4 : 15000 * 9 = 240 : 30 : 135 = 80 : 10 : 45$$

$$= 16 : 2 : 9$$

Question54

The third proportional to $x^2 - y^2$, $x - y$ is?

(a) $x + y$

(b) $x - y$

(c) $x - y / (x + y)$

(d) 1

Answer: C

Explanation:

A simple problem involving geometric progression (G.P)

In each term, a term of $(x + y)$ is divided.

Hence the third term becomes $x - y / (x + y)$

Question55

If the ratio of present ages of jeet and jay is 5:7 and after 6 years the ratio will be 3:4, what is the present age of jay?

(a) 42

(b) 30

(c) 36

(d) None of these

Answer: A

Explanation:

As the present age of jeet and jay are in the ratio 5: 7, let their ages be $5x$ and $7x$ respectively.

Therefore, their ages after 6 years will be $(5x + 6)$ and $(7x + 6)$ respectively.

Now, it is given that $\frac{(5x+6)}{(7x+6)} = \frac{3}{4}$

$$4 \times (5x + 6) = 3 \times (7x + 6)$$

$$20x + 24 = 21x + 18$$

$$\Rightarrow 6 = x$$

$$\Rightarrow x = 6$$

$$\text{Present age of jay} = 7x = 7 \times 6 = 42$$

Question56

What is the fourth proportional to the numbers 2, 5, 8?

- (a) 40 (b) 20
(c) 15 (d) 10

Answer: B

Explanation:

$$2/5 = 8/x: x = 40/2 = 20$$

Question57

The ratio between the speeds of two trains is 7:8. If the second train runs 400kms. In 5 hours, the speed of the first train is:

- (a) 10 km/hr. (b) 50 km/hr.
(c) 70 km/hr. (d) None of these

Answer: C

Explanation:

Speed = Distance/Time

$$2^{\text{ND}} \text{ train: speed} = 400 / 5$$

$$= 80 \text{ km/hr.}$$

$$1^{\text{st}} \text{ train speed} = (80/8) \times 7 \text{ km/hr.}$$

$$= 70 \text{ km/hr.}$$

Question58

If $(5x-3y)/(5y-3x) = 3/4$, the value of x: y is:

- (a) 2:9 (b) 7:2
(c) 27:29 (d) none of these

Answer: C

Explanation:

$$(5x - 3y) / (5y - 3x) = 3/4$$

Cross multiplying the numbers in the left and right,

$$4(5x - 3y) = 3(5y - 3x)$$

Opening the brackets,

$$20x - 12y = 15y - 9x$$

Grouping like terms to one side,

$$20x + 9x = 15y + 12y$$

$$29x = 27y$$

$$\rightarrow 29 * x = 27 * y$$

$$\rightarrow X/y = 27 / 29$$

$$\rightarrow X: y = 27:29$$

Question59

A number consist of three digits of which the middle one is zero and the sum of the other digit is 9. The number formed by interchanging the first and third digit is more than the original number by 297. Find the number:

(a) 405

(b) 306

(c) 504

(d) 103

Answer: B

Explanation:

Let "x0y" be the required three-digit number. (As per the given information, middle digit is zero)

"The sum of the other digits is 9" ---> $x + y = 9$ ---- (1)

"Interchanging the first and third digits " -----> y0x

From the information given in the question we can have

$$Y0x - x0y = 207$$

$$(100y + x) - (100x + y) = 297$$

$$100y + x - 100x - y = 297$$

$$-99x + 99y = 297$$

$$-x + y = 3 \text{ ----- (2)}$$

Solving (1) & (2), we get $x = 3$ and $y = 6$

So,

$$X0y = 306$$

Hence the required number is 306.

Question60

Show that $\left(\frac{x^a}{x^b}\right)^{1/ab} \times \left(\frac{x^b}{x^c}\right)^{1/bc} \times \left(\frac{x^c}{x^a}\right)^{1/ca}$ reduce to:

(a) 1

(b) 3

(c) 0

(d) 2

Answer: A

Explanation:

$$\left(\frac{x^a}{x^b}\right)^{1/ab} \times \left(\frac{x^b}{x^c}\right)^{1/bc} \times \left(\frac{x^c}{x^a}\right)^{1/ca}$$

$$\frac{x^a \times \frac{1}{ab}}{x^b \times \frac{1}{ab}} \times \frac{x^b \times \frac{1}{bc}}{x^c \times \frac{1}{bc}} \times \frac{x^c \times \frac{1}{ca}}{x^a \times \frac{1}{ca}}$$

$$\frac{x^{\frac{1}{b}}}{x^{\frac{1}{a}}} \times \frac{x^{\frac{1}{c}}}{x^{\frac{1}{b}}} \times \frac{x^{\frac{1}{a}}}{x^{\frac{1}{c}}}$$

For more Info Visit - www.KITest.in

of producing each unit is Rs. 30, while each floppy could be sold at Rs. 45.

Find:

(i) The total cost function for producing x floppies; and

(ii) The break - even point

(a) $C(x) = 45x + 200000, 198000$

(b) $C(x) = 30x + 200000, 19200$

(c) $C(x) = 30x + 288000, 19200$

(d) None of these

Answer: C

Explanation:

(i) Cost of floppy + cost on technical information + Cost of setting up

$$30x + 200000 + 88000$$

$$30x + 288000$$

(ii) By the option Method

$$45 = 864000 = 19200$$

$$30 + 288000, 19200$$

So, if the owner sells 19200 units of floppy, then only, he will be on BEP

Question 65

Division of Rs. 324 between x and y is in the ratio 11:7. X and y would get

Rupees:

(a) (208,120)

(b) (200,124)

(c) (180,144)

(d) (198,126)

Answer: D

Explanation:

Ratio of division is 11:7 so,

X share = 11a and y is 7a

$$\text{Total } 11a + 7a = 18a$$

$$18a = 324$$

$$a = 18$$

$$\text{x share} = 11a = \text{Rs. } 198$$

$$\text{y share} = 7a = \text{Rs. } 126$$

Question 66

If $\frac{a}{4} = \frac{b}{5}$ then:

(a) $\frac{a+4}{a-4} = \frac{b+4}{b-4}$

(b) $\frac{a+4}{a-4} = \frac{b+5}{b-5}$

(c) $\frac{a-4}{a+4} = \frac{b+5}{b-5}$

(d) None of these

Answer: B

Explanation:

By Componendo Dividendo: -

$$a/4 = b/5 \Rightarrow a/4 + 1 \Rightarrow (a + 4) / (b + 5) = 4/5$$

$$a/4 = b/5 \Rightarrow a/4 - 1 = b/5 - 1 \Rightarrow (a - 4) / (b - 5) = 4/5$$

For more Info Visit - www.KITest.in

$$\frac{a+4}{a-4} = \frac{b+5}{b-5}$$

PREPARE FOR WORST

Question 1

$(1331)^{-(2/3)}$ B

- | | |
|----------------------|-----------------------|
| (a) $-\frac{1}{11}$ | (b) $-\frac{11}{121}$ |
| (c) $-\frac{1}{121}$ | (d) $-\frac{121}{11}$ |

Question 2

$(32)^{(n/5)} \times 2^{2n+}$

$$\frac{4^n \times 2^{n-1}}$$

- | | |
|-----------|---------------|
| (a) 4 | (b) 8 |
| (c) 2^n | (d) 2^{n+1} |

Question 3

[.]”

- | | |
|---------|---------|
| (a) 132 | (b) 177 |
| (c) 185 | (d) 225 |

Question 4

If $2 \times 8^{(1/4)} = 2^{(1/4)}$ then find the value of x

- | | |
|--------------------|--------------------|
| (a) $-\frac{1}{2}$ | (b) $\frac{1}{2}$ |
| (c) $\frac{1}{4}$ | (d) $-\frac{1}{4}$ |

Question 5

If $9^x - 9^{x-1} = 648$, then find the value of x^x

- | | |
|--------|--------|
| (a) 4 | (b) 9 |
| (c) 27 | (d) 64 |

Question 6

If $4^{(x-y)} = 64$ and $4^{(x+y)} = 1024$, then find the value of x.

- | | |
|-------|-------|
| (a) 3 | (b) 1 |
| (c) 6 | (d) 4 |

Question 7

If a and b are whole numbers such that $a^b = 121$, then find the value of $(a-1)^{b+1}$

- | | |
|------------|------------|
| (a) 0 | (b) 10 |
| (c) 10^2 | (d) 10^3 |

Question 8

$\log_2 64$

- | | |
|--------|--------|
| (a) 6 | (b) 8 |
| (c) 16 | (d) 32 |

Question 9

$$\log_7 \left[\frac{1}{2401} \right]$$

- (a) 7 (b) -3
(c) -4 (d) 9

Question 10

$$49 \log_7 4$$

- (a) 7 (b) 14
(c) 16 (d) 18

Question 11

$$\text{Simplify } \left[\frac{1}{\log_{ab}(abc)} + \frac{1}{\log_{bc}(abc)} + \frac{1}{\log_{ac}(abc)} \right]$$

- (a) 0 (b) 1
(c) 2 (d) abc

Question 12

$$\text{Simplify: } \log_4 3 \times \log_{243} 64$$

- (a) 3/5 (b) 2/5
(c) 3/4 (d) 1/3

Question 13

If $x^a = y^b$ then

- (a) $\frac{\log x}{\log y} = \frac{a}{y}$ (b) $\frac{\log x}{\log y} = \frac{b}{a}$
(c) $\frac{\log x}{\log y} = \frac{x}{y}$ (d) None of these

Question 14

Find the value of x which satisfies the given expression $[\log_{10} 2 + \log (4x + 1) = \log (x + 2) + 1]$

- (a) 6 (b) 7
(c) -6 (d) -9

Question 15

A bag contains 50 P, 25 P and 10 P coins in the ratio 5: 9: 4, amounting to Rs. 206. Find the number of coins of each type respectively

Question 16

Two numbers are respectively 20% and 50% more than a third number. The ratio of the two numbers is:

Question 17

Salaries of Ravi and Sumit are in the ratio 2:3. If the salary of each is increased by Rs. 4000, the new ratio becomes 40:57. What is Sumit's salary?

Question 18

A sum of Rs.312 was divided among 100 boys and girls in such a way that the boy gets Rs.3.60 and each girl Rs. 2.40 the number of girls is:

Question 19

If Rs. 782 be divided into three parts, proportional to 12:23:34, then the first part is?

Question 20

A mixture contains alcohol and water in the ratio 4 : 3. If 5 liters of water is added to the mixture, the ratio becomes 4: 5. Find the quantity of alcohol in the given mixture

Question 21

The compounded ratio of (2: 3), (6: 11) and (11 :2) is

Question 22

If $0.75: x:: 5:8$, then x is equal to:

Question 23

The third proportional to x^2-y^2 and x-y is:

Question 24

Seats for Mathematics, Physics and Biology in a school are in the ratio 5:7:8. There is a proposal to increase these seats by 40%, 50% and 75% respectively. What will be the ratio of increased seats?

Question 25

A sum of Rs. 427 is to be divided among A, B and C such that 3 times A's share, 4 times B's share and 7 times C's share are all equal. The share of C is:

Question 26

If 76 are divided into four parts proportional to 7, 5, 3, 4, then the smallest part is:

Question 27

Alloy A contains 40% gold and 60% silver. Alloy B contains 35% gold and 40% silver and 25% copper. Alloys A and B are mixed in the ratio of 1:4. What is the ratio of gold and silver in the newly formed alloy is?

Question 28

If the ratio of the ages of two friends A and B is in the ratio 3: 5 and that of B and C is 3: 5 and the sum of their ages is 147, then how old is B?

Question 29

The concentration of petrol in three different mixtures (petrol and kerosene) is $\frac{1}{2}$, $\frac{3}{5}$ and $\frac{4}{5}$ respectively. If 2 litres, 3 litres and 1 litre are taken from these three different vessels and mixed. What is the ratio of petrol and kerosene in the new mixture?

Question 30

The wages of labourers in a factory increases in the ratio 22:25 and there was a reduction in

the number of labourers in the ratio 15:11. Find the original wage bill if the present bill is Rs. 5000?

Question 31

Vinod have 20 rupees. He bought 1, 2, 5 rupee stamps. They are different in numbers by the reason of no change; the shop keeper gives 3 one rupee stamps. So how many stamps Vinod have?

Question 32

A and B invests Rs.8000 and Rs.9000 in a business. After 4 months, A withdraws half of his capital and 2 months later, B withdraws one-third of his capital. In what ratio should they share the profits at the end of the year?

Question 33

The incomes of two persons A and B are in the ratio 3: 4. If each saves Rs.100 per month, the ratio of their expenditures is Rs. 1: 2. Find their incomes.

Question 34

Three cats are roaming in a zoo in such a way that when cat A takes 5 steps, B takes 6 steps and C takes 7 steps. But the 6 steps of A are equal to the 7 steps of B and 8 steps of C. what is the ratio of their speeds?

Question 35

In a competitive exam, the number of passed students was four times the number of failed students. If there had been 35 fewer appeared students and 9 more had failed, the ratio of passed and failed students would have been 2: 1, then the total number of students appeared for the exam?

Question 36

In MaaYatri Temple every devotee offers fruits to the orphans. Thus every orphan receives bananas, oranges and grapes in the ratio of 3:2:7 in terms of dozens. But the weight of a grape is 24 gm and weight of a banana and an orange are in the ratio of 4:5, while the weight of an orange is 150gm. Find the ratio of all the three fruits in terms of weight, that an orphan gets

Question 37

In a class of 39 students the ratio of boys and girls is 2: 1. Radhika ranks 15th among all the students from top and 8th among girls from bottom. How many boys are there below Radhika?

Question 38

The ratio of students in a coaching preparing for B. tech and MBA is 4: 5. The ratio of fees collected from each of B. tech and MBA students is 25: 16. If the total amount collected from all the students is 1.62 lakh, what is the total amount collected from only MBA aspirants?

Question 39

Two solutions have milk & water in the ratio 7:5 and 6:11. Find the proportion in which these two solutions should be mixed so that the resulting solution has 1 part milk and 2 parts waters?

Question 40

The ratio of the angles of a triangle is 3: 4: 5. The three angles of a quadrilateral is equal to three angles of this triangle. What is the sum of the largest angle and second smallest angle of the quadrilateral?

ANSWERS AVAILABLE ON:

- TELEGRAM CHANNEL: <https://t.me/kinshukInstitute>
- WEBSITE : WWW.KITest.IN
- KITest APP

PAST EXAMINATION QUESTIONS

2018 - MAY

Question 1

If p: q is the sub - duplicated ratio of $p-x^2$: $q-x^2$, then x^2 is:

- | | |
|----------------------|---------------------|
| (a) $\frac{p}{p+q}$ | (b) $\frac{q}{p+q}$ |
| (c) $\frac{pq}{p+q}$ | (d) None |

Answer: C

Explanation:

Sub duplicate ratio of $(p-x^2) : (q-x^2) = \sqrt{p-x^2} : \sqrt{q-x^2}$

$$p:q = \sqrt{p-x^2} : \sqrt{q-x^2}$$

$$\frac{p}{q} = \frac{\sqrt{p-x^2}}{\sqrt{q-x^2}}$$

An squaring both side

$$\frac{p^2}{q^2} = \frac{p-x^2}{q-x^2}$$

$$P^2(q-x^2) = q^2(p-x^2)$$

$$P^2q - q^2p = p^2x^2 - q^2x^2$$

$$X^2 = \frac{pq(p-q)}{(p+q)(p-q)}$$

$$X^2 = \frac{pq}{(p+q)}$$

Question 2

The value of the expression:

$$a^{\log_a^b \cdot \log_b^c \cdot \log_c^d \cdot \log_d^t}$$

- (a) t (b) abcdt
(c) (a+b+c+d+t) (d) None

Answer: A

Explanation:

$$a^{\log_a^b \cdot \log_b^c \cdot \log_c^d \cdot \log_d^t}$$

$$a^{\frac{\log^b}{\log^a} \cdot \frac{\log^c}{\log^b} \cdot \frac{\log^d}{\log^c} \cdot \frac{\log^t}{\log^d}}$$

$$a^{\frac{\log^t}{\log^a}}$$

$$a \log_a^t$$

$$= t$$

Question3

The mean proportional between 24 and 54 is:

- (a) 33 (b) 34
(c) 35 (d) 36

Answer: D

Explanation:

$$b^2 = ac$$

$$b^2 = 24 \times 54$$

$$b = \sqrt{1296}$$

$$b = 36$$

Question 4

$$\frac{2^n + 2^n - 1}{2^{n+1} - 2^n}$$

- (a) $\frac{1}{2}$ (b) $\frac{3}{2}$
(c) $\frac{2}{3}$ (d) $\frac{1}{3}$

Answer: B

Explanation:

$$\frac{2^n + 2^{n-1}}{2^{n+1} - 2^n} = \frac{2^n + 2^n \cdot 2^{-1}}{2^n \cdot 2^{+1} - 2^n}$$

$$\frac{2^n + (1 + 2^{-1})}{2^n \cdot (2 - 1)}$$

$$\frac{\left(1 + \frac{1}{2}\right)}{1}$$

$$\frac{3}{2}$$

$$1$$

$$= \frac{3}{2}$$

2018 – NOV

Question 5

$\frac{3X-2}{5X+6}$ is the duplicate ratio of $\frac{2}{3}$ then find the value of x:

- (a) 2 (b) 6
(c) 5 (d) 9

Answer: B

Explanation:

$\frac{3X-2}{5X+6}$ is the duplicate ratio of $\frac{2}{3}$

$$\text{i.e., } \frac{3X-2}{5X+6} = \frac{2^2}{3^2}$$

$$\frac{3X-2}{5X+6} = \frac{4}{9}$$

$$27x-18 = 20x+24$$

$$27x-20x = 24+18$$

$$7x = 42$$

$$X = 6$$

Question 6

If x: y: z = 7:4:11 then $\frac{x+y+z}{z}$ is:

- (a) 2 (b) 4
(c) 3 (d) 5

Answer: A

Explanation:

If x: y: z = 7:4:11

Let x=7k, y=4k, z=11k

$$\frac{x+y+z}{z} = \frac{7k+4k+11k}{11k} = \frac{22k}{11k} = 2$$

Question 7

$\log_2 \log_2 \log_2 16 = ?$

- (a) 0 (b) 3
(c) 1 (d) 2

Answer: C

Explanation:

$$\log_2 \log_2 \log_2 16$$

$$\log_2 \log_2 \left(\log_2 \frac{2^4}{2} \right)$$

$$\log_2 \log_2^4 \log_2^2$$

$$\log_2 \log_2^4$$

$$\log_2^2 \log_2^2$$

$$1 * 1$$

$$1$$

2019 - MAY

Question 1

If the ratio of two numbers is 7: 11. If 7 is added to each number, then the new ratio will be 2: 3 then the number are.

- (a) 49, 77 (b) 42, 45
(c) 43, 42 (d) 39, 40

Answer: A

Explanation:

$$\frac{7x+7}{11x+7} = \frac{2}{3}$$

$$3(7x+7) = 2(11x+7)$$

$$21x+21 = 22x+14$$

$$21-14 = 22x-21x$$

$$X = 7$$

$$7x = 7 \times 7 = 49$$

$$11x = 11 \times 7 = 77$$

Question 2

$\log_{2\sqrt{2}}(512): \log_{3\sqrt{2}} 324 =$

- (a) 128 : 81 (b) 2 : 3
(c) 3 : 2 (d) None

Answer: C

Explanation:

$$= \frac{\log_{2\sqrt{2}}(512)}{\log_{3\sqrt{2}} 324}$$

$$= \frac{\log 512}{\log^2 \sqrt{2}}$$

$$= \frac{\log 512}{\log^2 \sqrt{2}}$$

$$= \frac{\log 512}{\log^2 \sqrt{2}}$$

$$= \frac{0.4514}{2.5116}$$

$$= \frac{0.6275}{2.5116}$$

$$\frac{6}{4} = \frac{3}{2}$$

Question 3

If $2^{x^2} = 3^{y^2} = 12^{x^2}$ then

(a) $\frac{1}{x^2} + \frac{1}{y^2} = \frac{1}{z^2}$

(b) $\frac{1}{x^2} + \frac{2}{y^2} = \frac{1}{z^2}$

(c) $\frac{2}{x^2} + \frac{1}{y^2} = \frac{1}{z^2}$

(d) None

Answer: C**Explanation:**

$$2x^2 = k$$

$$\log 2x^2 = \log k$$

$$x^2 = \frac{\log k}{\log 2}, y^2 = \frac{\log k}{\log 3}, z^2 = \frac{\log k}{\log 12}$$

$$\frac{2}{x^2} + \frac{1}{y^2} = \frac{1}{z^2}$$

Question 4**Then value of $\log_5\left[1 + \frac{1}{5}\right] + \dots + \log_5\left[1 + \frac{1}{624}\right] =$**

(a) 2

(b) 3

(c) 5

(d) 0

Answer: B**Explanation:**

$$\log_5 \frac{6}{5} + \log_5 \frac{7}{6} + \log_5 \frac{8}{7} + \dots + \log_5 \frac{625}{624}$$

$$\log_5 5^a + \log_5 5^b + \log_5 5^c = \log_5 (a.b.c.d)$$

$$\Rightarrow \log_5 = \left(\frac{6}{5} \times \frac{7}{6} \times \frac{8}{7} \times \frac{625}{624}\right)$$

$$\Rightarrow \log_5 \left(\frac{625}{5}\right) = 125$$

$$\Rightarrow \log_5 (125)$$

$$\Rightarrow \log_5 5^3$$

$$\Rightarrow 3$$

Question 5**If $4x^3 + 8x^2 - x - 2 = 0$ then value of $2x - 3$**

(a) -4, 2, -7

(b) -4, -2, -7

(c) 4, 2, 7

(d) $\frac{1}{2}, \frac{1}{2}, -2$ **Answer: B****Explanation:**

$$4x^3 + 8x^2 - x - 2 = 0$$

$$4x^2(x+2) - 1(x+2) = 0$$

$$(x+2)(4x^2 - 1) = 0$$

$$x = -2, \frac{1}{2}, -\frac{1}{2}$$

Then the value of $2x + 3$ at $x = -2$

$$2 \times (-2) + 3 = -4 + 3 = -1$$

$$\text{at } x = \frac{1}{2}$$

$$2 \times (-1/2) + 3 - 1 + 3 = 2$$

2019 – NOV

Question 1

The ratio of two numbers are 3:4. The difference of their squares is 28 Greater no is:

- (a) 8 (b) 12
(c) 24 (d) 64

Answer: A

Explanation:

Let the two numbers be x and y

Greater no. y

Smaller no x

According to questions,

$$\frac{x}{y} = \frac{3}{4} \text{Eq1} \quad \text{and} \quad y^2 - x^2 = 28 \text{ ----Eq2}$$

Further solving Eq 1

$$X = \frac{3}{4}y \text{ -----Eq3}$$

Put Eq 3 in Eq 2

$$Y^2 - \left(\frac{3}{4}y\right)^2 = 28$$

$$\frac{y^2}{1} - \frac{9y^2}{16} = 28$$

$$\frac{7y^2}{16} = 28$$

$$Y^2 = \frac{28 \times 16}{7}$$

$$Y^2 = 64$$

$$\Rightarrow y = 8 \quad \text{(square root both sides)}$$

So, the greater number i.e. y is equal to 8.

Question 2

The price of scooter and moped are in the ratio 7:9. The price on moped is Rs. 1,600 more than that of scooter. Then the price of moped is:

- (a) 7,200 (b) 5,600
(c) 800 (d) 3700

Answer: A

Explanation:

$$\frac{\text{price of scooter}}{\text{price of moped}} = \frac{7}{9}$$

Let; the price of scooter = 7x and price of moped = 9x

According to question

$$9x = 7x + 1600$$

$$2x = 1600$$

$$x = \text{Rs}800$$

So; the price of moped = $9x = 9(800) = \text{Rs. } 7200$

Question 3

$\log_{0.01} 10,000 = ?$

- (a) 2 (b) -2
(c) 4 (d) -4

Answer: B

Explanation:

$$\log_{0.01}$$

$$= \log \left(\frac{1}{100} \right)$$

$$= \log \left(\frac{1}{10^2} \right)$$

$$= \log 10^{-2} \rightarrow \text{use property } x^{-n} = \frac{1}{x^n}$$

$$= -2 \log 10 \rightarrow \text{use property } \log_b x^n = n \log_b x$$

$$= -2(1) \rightarrow \log 10 = 1$$

$$= -2$$

Question 4

Value of $\left[9n^4 \frac{\sqrt{3 \cdot 3^n}}{3 \cdot \sqrt{3^n}} \right]^{\frac{1}{4}}$

- (a) 9 (b) 27
(c) 81 (d) 3

Answer: B

Explanation:

$$= \left[9n^4 \frac{\sqrt{3 \cdot 3^n}}{3 \cdot \sqrt{3^n}} \right]^{\frac{1}{4}}$$

$$= \left[\frac{(3^2)^{\frac{4n+1}{4}} \sqrt{3^{n+1}}}{3 \cdot \sqrt{3^{-n}}} \right]^{\frac{1}{n}}$$

$$\text{Since } \frac{a^m}{a^n} = a^{m-n}$$

$$\Rightarrow \left[\frac{3^{\frac{4n+1}{2}} \cdot (3^{n+1})^{\frac{1}{2}}}{3 \cdot (3^{-n})^{\frac{1}{2}}} \right]^{\frac{1}{n}}$$

$$\Rightarrow \left[(3)^{\frac{4n+1}{2}-1} \times (3)^{\frac{n+1}{2}-\frac{(-n)}{2}} \right]^{\frac{1}{n}}$$

$$\Rightarrow \left[3^{\frac{4n-1}{2}} \times (3)^{\frac{2n+1}{2}} \right]^{\frac{1}{n}}$$

$$\text{Since } a^m \times a^n = a^{m+n}$$

$$\Rightarrow \left[3^{\frac{4n-1}{2} + \frac{2n+1}{2}} \right]^{\frac{1}{n}}$$

$$\Rightarrow \left[(3)^{\frac{6n}{2}} \right]^{\frac{1}{n}}$$

$$\Rightarrow [3^{3n}]^{\frac{1}{n}}$$

$$\Rightarrow (3)^3$$

$$\Rightarrow 27$$

DEC - 2020

Question 1

Find the value of 'a' from the following

$$(\sqrt{9})^{-5} \times (\sqrt{3})^{-7} = (\sqrt{3})^{-a}$$

- (a) 13 (b) 11
(c) 15 (d) 17

Answer: D

Explanation:

$$(\sqrt{9})^{-5} \times (\sqrt{3})^{-7} = (\sqrt{3})^{-a}$$

$$(\sqrt{3^2})^{-5} \times (\sqrt{3})^{-7} = (\sqrt{3})^{-a}$$

$$(\sqrt{3})^{-10} \times (\sqrt{3})^{-7} = (\sqrt{3})^{-a}$$

$$(\sqrt{3})^{-10+(-7)} = (\sqrt{3})^{-a}$$

$$= -a = -17$$

$$= a = 17$$

Question 2

If $\log_a(\sqrt{3}) = \frac{1}{6}$ find the value of 'a'

- (a) 81 (b) 9
(c) 27 (d) 3

Answer: C

Explanation:

$$\log_{27} \sqrt{3} = \frac{1}{6}$$

$$\Rightarrow a^{\frac{1}{6}} = \sqrt{3}$$

$$\Rightarrow a = \left(3^{\frac{1}{2}}\right)^6$$

$$\Rightarrow a = 3^3$$

$$\Rightarrow a = 27$$

Question 3**Log 9 + log 5 is expressed as ___**

- (a) $\log (9/5)$ (b) $\log 4$
 (c) $\log (5/9)$ (d) $\log 45$

Answer: D**Explanation:**

$$\log 9 + \log 5 = \log 9 \times 5$$

$$\log = 45.$$

Question 4**The ratio of no. of boys and the no. of girls in a school is found to be 15: 32. How many boys and equal no. of girls should be added to bring the ratio to 2/3?**

- (a) 20 (b) 19
 (c) 23 (d) 27

Answer: B**Explanation:**

By option

$$\frac{15x + 19}{32x + 19} = \frac{2}{3}$$

$$45x + 57 = 64x + 38$$

$$19x = 19$$

$$x = 19$$

$$x = 19$$

Question 5**If a: b = 9:4 then $\sqrt{\frac{a}{b}} + \sqrt{\frac{b}{a}} = ?$**

- (a) $2/3$ (b) $3/2$
 (c) $6/13$ (d) $13/6$

Answer: D**Explanation:**

$$a: b = 9:4 \quad \frac{a}{b} = \frac{9}{4}$$

$$\frac{3}{2} + \frac{2}{3} = \frac{9+4}{6} = \frac{13}{6}$$

Question 6**If a: b = 3: 7 then 3a + 2b: 4a + 5b = ?**

- (a) 27 : 43 (b) 23 : 47
 (c) 24 : 51 (d) 29 : 53

Answer: B**Explanation:**

$$\frac{a}{b} = \frac{3}{7}$$

Let $a = 3x$ and $b = 7x$

$$\therefore 3a + 2b = 3 \times 3x + 2 \times 7x = 23x$$

$$4a + 5b = 4 \times 3x + 5 \times 7x = 47x$$

$$\therefore \frac{3a+2b}{4a+5b} = \frac{23x}{47x} = 23:47$$

IAN - 2021

Question 1

Find the value of $\frac{3t^{-1}}{t^{-1/3}}$

(a) $\frac{3}{t^{2/3}}$

(b) $\frac{3}{t^{32}}$

(c) $\frac{3}{t^{1/3}}$

(d) $\frac{3}{t^2}$

Answer: A

Question 2

If $\log_a(ab) = x$, then $\log_b(ab)$ is

(a) $\frac{1}{x}$

(b) $\frac{x}{1+x}$

(c) $\frac{x}{x-1}$

(d) None of these

Answer: C

Explanation:

We have,

$$\log_a(ab) = x$$

$$\log_a a + \log_a b = x \quad [\log_a mn = \log_a m + \log_a n]$$

$$1 + \log_a b = x \quad [\log_a a = 1]$$

$$\log_a b = x - 1 \quad \dots\dots(1)$$

Since,

$$= \log_b(ab)$$

$$= \log_b a + \log_b b$$

$$= \log_b a + 1$$

$$= \frac{1}{\log_a b} + 1 \left[\frac{1}{\log_n m} = \log_m n \right] = \frac{1}{x-1} + 1 \frac{1+x-1}{x-1}$$

$$= \frac{x}{x-1}$$

Question 3

In a certain business, A and B received Profit in a certain ratio; B and C received profits in the same ratio. If A gets Rs. 1,600 and C gets Rs. 2,500, then how much does B get?

(a) Rs. 2,000

(b) Rs. 2,500

(c) Rs. 1,000

(d) Rs. 1,500

Answer: A**Explanation:**

let the ratio of profit of A and B is a:b

∴ Ratio of profit of B and C = a:b

A:B B:C

 $a \times a : b \times a : a \times b : b \times b$

Note: Value of B would be same in both cases

A: B: C

 $a^2 : ab : b^2$

According to the question,

$$a^2 = 1,600$$

$$a = 40$$

Similarly

$$b^2 = 2,500$$

$$b = 50$$

$$\text{Amount received by B} = ab = 40 \times 50 = 2000$$

Question 4**The ratio of two quantities is 15:17. If the consequent of its inverse ratio is 15, then the antecedent is.**

(a) 15

(b) $\sqrt{15}$

(c) 17

(d) 14

Answer: C**Explanation:**

If consequent is 15

i.e., 15 so 17 will be answer

It's just a inverse

Question 5**The salaries of A, B and C are in the ratio 2:3:5. If increments of 15%, 10% and 20% are allowed respectively to their salaries, then what will be the new ratio of their salaries?**

(a) 3 : 3 : 10

(b) 10 : 11 : 20

(c) 23 : 33 : 60

(d) Cannot be determined

Answer: C**Explanation:**

Let A=2k, B=3k and C=5k.

A's new salary

$$\frac{115}{100} \text{ of } 2k$$

$$\left(\frac{115}{100} \times 2k\right) = \frac{23}{10}$$

B's new salary

$$\frac{110}{100} \text{ of } 3k$$

$$\left(\frac{110}{100} \times 3k\right) = \frac{33}{10}$$

C's new salary

$$\frac{120}{100} \text{ of } 5k$$

$$\left(\frac{120}{100} \times 5k\right) = 6k$$

\therefore New ratio

$$= \frac{23k}{10} : \frac{33k}{10} : 6k$$

$$= 23:33:60$$

JULY - 2021

Question 1

If $xy + yz + zx = -1$, the value of $\left(\frac{x+y}{1+xy} + \frac{y+z}{1+yz} + \frac{z+x}{1+zx}\right)$ is

(a) xyz

(b) $\frac{-1}{yz}$

(c) $\frac{1}{xyz}$

(d) $\frac{1}{x+y+z}$

Answer: Options (c)

Explanation:

$$xy + yz + zx = 1$$

$$Z(x + y) = 1 - xy$$

$$\frac{x+y}{1-xy} = \frac{1}{z} \quad \rightarrow \text{Equation (1)}$$

$$\frac{y+z}{1-yz} = \frac{1}{z} \quad \rightarrow \text{Equation (2)}$$

$$\rightarrow \frac{x+y}{1-xy} + \frac{y+z}{1-yz} + \frac{z+x}{1-zx}$$

$$= \frac{1}{z} + \frac{1}{x} + \frac{1}{y}$$

$$= \frac{xy+yz+zx}{xyz}$$

$$= \frac{1}{xyz}$$

Question 2

If $\log_4 x + \log_{16} x + \log_{64} x + \log_{256} x = 25/6$ then the value of x is

- (a) 64 (b) 4
(c) 16 (d) 2

Answer: Options (c)

Explanation:

$$\log_4 x + \log_{16} x + \log_{64} x + \log_{256} x = \frac{25}{6}$$

$$\rightarrow \frac{1}{\log_x 4} + \frac{1}{2 \log_x 4} + \frac{1}{3 \log_x 4} + \frac{1}{4 \log_x 4} = \frac{25}{6}$$

$$\rightarrow \frac{1}{\log_x 4} \left(1 + \frac{1}{2} + \frac{1}{3} + \frac{1}{4} \right) = \frac{25}{6}$$

$$\rightarrow \log_4 x \left(\frac{12+6+4+3}{12} \right) = \frac{25}{6}$$

$$\rightarrow \log_4 x \left(\frac{25}{12} \right) = \frac{25}{6}$$

Inverse the fraction both side

$$\rightarrow \log_4 x \frac{25}{25} = \frac{12}{6}$$

$$\rightarrow \text{Log } x = (4)^2$$

$$\rightarrow x = 16$$

Question 3

The salaries of A, B and C are of ratio 2:3:5. If the increments of 15%, 10% and 20% are done their respective salaries, then find the new ratio of the salaries.

- (a) 23:33:60 (b) 33:23:60
(c) 23:60:33 (d) 33:60:23

Answer: Options (a)

Explanation:

Let the constant be x

Then, Salaries of A, B, C are 2x, 3x, 5x respectively.

Increments in Salary of A = 15%

$$\text{Therefore A's new salary} = \text{Rs. } \left(2x + \frac{15}{100} \times 2x \right) = \text{Rs. } \frac{230x}{100}$$

Increment in B's new salary = Rs. 10%

$$\text{Therefore, B's new salary} = \text{Rs. } \left(3x + \frac{10}{100} \times 3x \right) = \text{Rs. } \frac{330x}{100}$$

Increment in C's salary = 20%

$$\text{Therefore C's new salary} = \text{Rs. } \left(5x + \frac{20}{100} \times 5x \right) = \text{Rs. } 6x$$

Therefore our ratio is 23: 33: 60

DEC – 2021**Question 1**

Let $a = (\sqrt{5} + \sqrt{3})(\sqrt{5} - \sqrt{3})$ and $b = (\sqrt{5} - \sqrt{3})(\sqrt{5} + \sqrt{3})$. What is the value of $a^2 + b^2$

- (a) 64 (b) 62
(c) 62 (d) 254

Answer: b

Explanation:

$$a = \frac{\sqrt{5} + \sqrt{3}}{\sqrt{5} - \sqrt{3}} = \frac{3.9681}{0.5040} = 7.8732$$

$$b = \frac{\sqrt{5} - \sqrt{3}}{\sqrt{5} + \sqrt{3}} = \frac{0.5040}{3.9681} = 0.1270$$

$$a^2 + b^2 = (7.8732)^2 + (0.1270)^2 = 62$$

Question 2

Income of R and S are in the ratio 7:9 and their expenditures are in the ratio 4:5. Their total expenditure is equal to income of R. What is the ratio of their savings?

- (a) 23:36 (b) 21:43
(c) 28:41 (d) 35:46

Answer: d

Explanation:

Let the incomes of R and S be $7x$ and $9x$ respectively, and their expenditures be $4y$ and $5y$ respectively.

Savings of R = $7x - 4y$

Savings of S = $9x - 5y$

Also, it is given that their total expenditure is equal to the income of R.

Therefore, $4y + 5y = 7x$

$$= 9y = 7x$$

$$x = \frac{9y}{7} \dots \text{Eq. (1)}$$

Ratio of their expenditures $\frac{7x - 4y}{9x - 5y}$

Putting the value of $x = \frac{9y}{7}$ from Eq 1

Above:

$$7 \left(\frac{9y}{7} \right) - 4y$$

$$9 \left(\frac{9y}{7} \right) - 5y$$

$$= \frac{81y - 35y}{7}$$

$$\frac{81y - 35y}{7}$$

$$\frac{81y - 35y}{7}$$

$$\begin{array}{r} 7 \times 5y \\ \hline 46y \\ 35 \\ \hline 46 \end{array}$$

Question 3

A bag contains 105 coins containing some 50 paise, and 25 paise coins. The ratio of the number of these coins is 4:3. The total value coins. The ratio of the number of these coins is 4:3. The total values (in Rs) in the bag id?

- (a) 43.25 (b) 41.25
(c) 39.25 (d) 35.25

Answer: b**Explanation:**

No. of 50 paise coins =

$$\frac{4}{7} \times 105 = 60$$

No. of 25 paise coins = $\frac{3}{7} \times 105 = 45$

Value of 1 50 paise coin = Rs.0.50

Therefore, value of 60-50 paise coins = $60 \times \text{Rs.}0.50 = \text{Rs } 30$

Value of 1 25-paise coin = Rs0.25

Therefore, value of 45-25 paise coins = $45 \times 0.25 = \text{Rs} = 11.25$

Therefore, total value = Rs 30+Rs 11.25 = Rs. 41.25

Question 4

If $\log_{10} 3 = x$ and $\log_{10} 4 = y$, then the value of $\log_{10} 120$ can be expressed as

- (a) $x-y+1$ (b) $x+y+1$
(c) $x+y-1$ (d) $2x+y-1$

Answer: b**Explanation:**

$$\log_{10} 120 = \log_{10} (3 \times 4 \times 10)$$

$$= \log_{10} 3 + \log_{10} 4 + \log_{10} 10$$

$$= x + y + 1$$

Question 5

Find the value of $\log(x^6)$, if $\log(x) + 2 \log(x^2) + 3 \log(x^3) = 14$

- (a) 3 (b) 4
(c) 5 (d) 6

Answer: d**Explanation:**

$$\log(x) + 2 \log(x^2) + 3 \log(x^3) = 14$$

$$\log x + (2 \times 2) \log x + (3 \times 3) \log x = 14$$

$$\log x + 4 \log x + 9 \log x = 14$$

$$14 \log x = 14$$

$$\log x \frac{14}{14} = 1$$

$$\log (x^6) = 6 \log x = 6 \times 1 = 6$$

Question 6

The value of $\frac{6^{n+4}3^{n+3} \times 2^{n+3}}{5 \times 6^n + 6^n}$ is

(a) 232

(b) 242

(c) 252

(d) 262

Answer: c

Explanation:

We can see that none of the option are in terms of n. This means that n is ultimately going to get cancelled out. Therefore, we can take any value and put it in place of n, and we'll get the same answer. For the sake of simplicity, let n=1.

Now,

$$\frac{6^{n+4}3^{n+3} \times 2^{n+3}}{5 \times 6^n + 6^n}$$

$$= \frac{6^{1+4}3^{1+3} \times 2^{1+3}}{5 \times 6^1 + 6^1}$$

$$= \frac{5 \times 6^1 + 1}{6^5 + 3^4 \times 2^4}$$

$$= \frac{5 \times 6 + 6}{7776 + 81 \times 16}$$

$$= \frac{30 + 6}{7776 + 1296}$$

$$= \frac{36}{9072}$$

$$= \frac{36}{36}$$

$$= 252$$

Question 7

In a department, the number of males and females are in the ratio 3:2. If 2 males and 5 females join the department, then the ratio becomes 1:1. Initially, the number of females in the department is

(a) 9

(b) 6

(c) 3

(d) 8

Answer: b

Explanation:

Let the initial number of males and females be 3x and 2x respectively.

$$\text{As per the question, } \frac{3x+2}{2x+5} = \frac{1}{1}$$

$$3x+2 = 2x+5$$

$$3x-2x=5-2$$

$$X=3$$

Therefore, initial number of females = $2 \times 3 = 6$

Question 8

If, $\left(\frac{3a}{2b}\right)^{2x-4} = \left(\frac{2b}{3a}\right)^{2x-4}$, for some a and b, then the value of x is

- (a) 8 (b) 6
(c) 4 (d) 2

Answer: d

Explanation:

Looking at the options, you'll find that if x is 2, then the powers of the LHS as well as RHS will become 0. Therefore, LHS and RHS both will be 1, and hence, be equal.

Question 9

The value of $\left(1 - \sqrt[3]{0.027} \left(\frac{5}{6}\right) \left(\frac{1}{2}\right)^2\right)$ is:

- (a) 11/16 (b) 13/16
(c) 15/16 (d) 1

Answer: c

Explanation:

$$\left(1 - \sqrt[3]{0.027} \left(\frac{5}{6}\right) \left(\frac{1}{2}\right)^2\right)$$

$$\left(1 - \sqrt[3]{\frac{27}{1000}} \left(\frac{5}{6}\right) \left(\frac{1}{2}\right)^2\right)$$

$$\left(1 - \left(\frac{3}{10}\right) \left(\frac{5}{24}\right)\right)$$

$$\left(1 - \left(\frac{1}{2} \times \frac{1}{8}\right)\right)$$

$$1 - \frac{1}{16}$$

$$\frac{16-1}{16} = \frac{15}{16}$$

Alternatively,

On calculator, calculate $\sqrt[3]{0.027}$, or $(0.027)^{\frac{1}{3}}$. Follow the following steps.

First, enter 0.027 on the calculator, then press the square root button 12 times. You'll get 0.99911857266

Then, from this, subtract 1 i.e., press -1

You'll get -0.00088142734.

Then, multiply this number with the power, i.e., $1/3$. Press $\times 1 \div 3 =$. You'll get -

0.00029380911.

Then add 1 to it, i.e., press +1. You'll get 0.99970619089.

Then press the button ($\times =$) 12 times. You'll get 0.30010617315.

This is $(0.027)^{\frac{1}{3}}$

Now, multiply this number with $\left\{\frac{5}{6}\left(\frac{1}{2}\right)^2\right\}$

You'll get 0.625221194. Then press M+

This will save this number in the memory of your calculator.

Then press 1-MRC =. You'll get 0.9374778806.

This is your final answer.

Now, try the options.

Option (a) = $11/16$

$11/16 = 0.8125$ not equal to 0.9375

Option (b) = $13/16$

$13/16 = 0.8125$ is not equal to 0.9375

Option c = $15/16$

$15/16 = 0.9375$

So answer is (c)

JUNE - 2022

Question 1

$\log\left(\frac{p^2}{qr}\right) + \log\left(\frac{q^2}{qr}\right) + \log\left(\frac{r^2}{pq}\right)$ is :

(a) pqr

(b) 0

(c) 1

(d) None

Answer: Options (b)

Explanation:

$\log\left(\frac{p^2}{qr}\right) + \log\left(\frac{q^2}{qr}\right) + \log\left(\frac{r^2}{pq}\right)$ is :

$$= \log\left(\frac{p^2}{qr} \times \frac{q^2}{pr} \times \frac{r^2}{pq}\right)$$

$$= \log\left(\frac{p^2 q^2 r^2}{p^2 q^2 r^2}\right)$$

$$= \log 1$$

$$= 0$$

Question 2

$\log \sqrt{3} = 6$ base a, then 'a' will be:

(a) 27

(b) 36

(c) 15

(d) 1

Answer: Options (a)

Explanation:

Here $\log \sqrt{3} a = 6$

$$\Rightarrow a = (\sqrt{3})^6$$

$$\Rightarrow a = (3^{1/2})^6$$

$$a = 3^3$$

$$a = 27$$

Question 3

A box contains 25 paise coins and '10' paise coins and 5 paise coins in ratios 3:2:1 and total money is ₹ 40. How many '5' paise coins are there?

(a) 65

(b) 55

(c) 40

(d) 50

Answer: Options (c)

Explanation:

The ratio of No. of 25p coins, 10p coins and 5p coins = 3:2:1

Let No. of 25p coins = $3x$

No. of 10p coins = $2x$

No. of 5p coins = x

Total value of all coins = 4000 paise

$$25p \times 3x + 10p \times 2x + 5p \times x = 4000p$$

$$(75x + 50x + 5x)p = 4000p$$

$$100x = 4000$$

$$x = \frac{4000}{100}$$

$$x = 40$$

No. of 5 paise coins = $x = 40$

Question 4

If $x:y = 4:6$ and $z:x = 4:6$ find y ?

(a) 4

(b) 6

(c) 16

(d) 1

Answer: Options (b)

Explanation:

If $x:y = 4:6$ and $z:x = 4:6$ find y

$$\Rightarrow z:x = 1:4$$

so, $y:x = 6:4$ and $x:z = 4:1$

$$y:x:z = 6:4:1$$

$$\text{so, } y = 6$$

Question 5

If $(\sqrt{3})^{18} = (\sqrt{9})^x$, find x ?

(a) 18

(b) 9

(c) 8

(d) 19

Answer: Options (b)**Explanation:**

$$\text{If } (\sqrt{3})^{18} = (\sqrt{9})^x$$

$$\left(3^{\frac{1}{2}}\right)^{18} = (3)^x$$

$$3^9 = 3^x$$

On comparing

$$9 = x$$

Question 6**log_{√2} 64 is equal to:**

(a) 12

(b) 6

(c) 1

(d) 8

Answer: Options (a)**Explanation:**

$$\log_{\sqrt{2}} 64 = \frac{\log 64}{\log \sqrt{2}} = \frac{\log 2^6}{\log (2)^{\frac{1}{2}}} = \frac{6 \log 2}{\frac{1}{2} \log 2} = 6 \times 2 = 12$$

DEC 2022**Question 1****If the roots of the equation $x^2 - px + q = 0$ are in the ratio 2:3, then**

a) $p^2 = 25q$

b) $p^2 = 6q$

c) $6p^2 = 5q$

d) $6p^2 = 25q$

Answer: d**Explanation:**

If the ratio of the quadratic equation

$$X^2 - Px + q = 0$$

Roots: a, b

$$a : b = 2 : 3$$

$$\frac{a}{b} = \frac{2}{3}$$

$$\therefore a = \frac{2b}{3}$$

$$a + b = -(-p) = p$$

$$ab = q$$

$$a + b = p$$

$$\frac{2b}{3} + b = p$$

$$\frac{2b + 3b}{3} = p$$

CHAPTER - 2

UNIT I: EQUATIONS

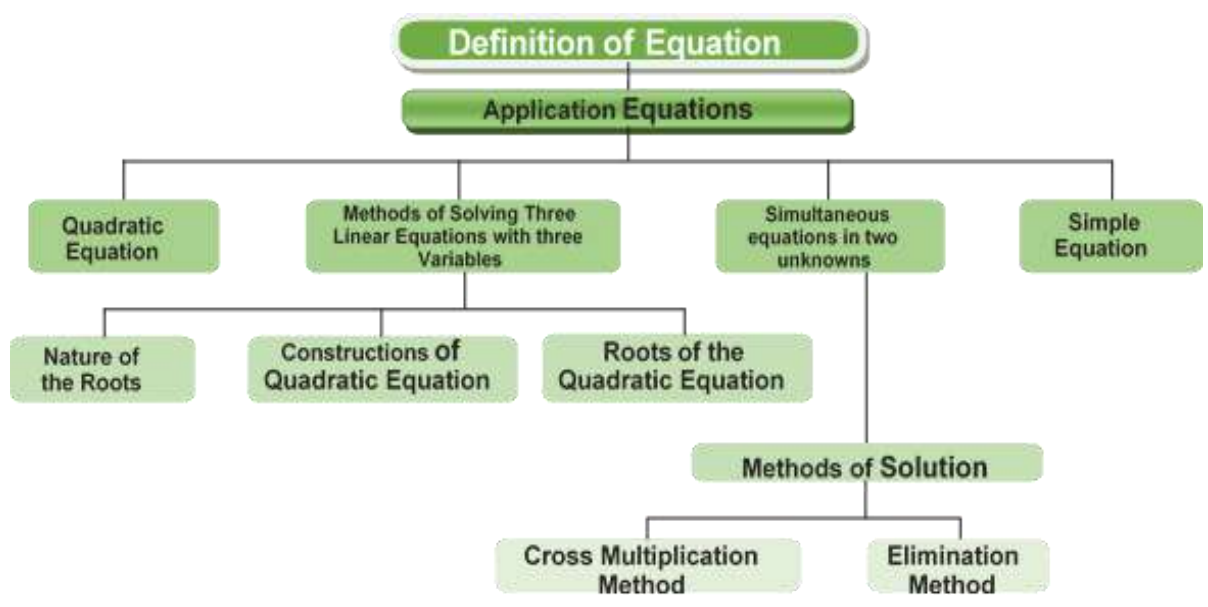

EQUATION	Equation is defined to be a mathematical statement of equality. If the equality is true for certain value of the variable involved, the equation is often called a conditional equation and equality sign '=' is used; while if the equality is true for all values of the variable involved, the equation is called an identity.
TYPES OF EQUATION	<p>Simultaneous Linear Equations: Two or more linear equations involving two or more variables.</p> <p>Quadratic equation: An equation of degree 2 (highest Power of the variable is 2)</p> <p>Cubic Equation: The equation of degree 3</p>
SIMPLE EQUATION	A simple equation in one unknown x is in the form $ax + b = 0$. Where a, b is known constants and $a \neq 0$
SIMULTANEOUS LINEAR EQUATIONS IN TWO UN KNOWN	<p>The general form of a linear equations in two unknowns' x and y is $ax + by + c = 0$ where</p> <p>a, b are non-zero coefficients and c is a constant. Two such equations $a_1x + b_1y + c_1 = 0$ and $a_2x + b_2y + c_2 = 0$ form a pair of simultaneous equations in x and y. A value for each unknown which satisfies simultaneously both the equations will give the roots of the equations.</p>

ELIMINATION METHOD	In this method two given linear equations are reduced to a linear equation in one unknown by eliminating one of the unknowns and then solving for the other unknown.
CROSS MULTIPLICATION METHOD	Let two equations be: $a_1x + b_1y + c_1 = 0$ $a_2x + b_2y + c_2 = 0$ $x = \frac{b_1c_2 - b_2c_1}{a_1b_2 - a_2b_1}$ $x = \frac{c_1a_2 - c_2a_1}{a_1b_2 - a_2b_1}$
QUADRATIC EQUATION	An equation of the form $ax^2 + bx + c = 0$ where x is a variable and a, b, c are constants with $a^1 \neq 0$ is called a quadratic equation or equation of the second degree. When $b=0$ the equation is called a pure quadratic equation; when $b \neq 0$ the equation is called an affected quadratic. The roots of a quadratic equation: $x = \frac{-b \pm \sqrt{b^2 - 4ac}}{2a}$
CONSTRUCT A QUADRATIC EQUATION	$x^2 - (\text{Sum of the roots})x + \text{Product of the roots} = 0$

**Question: 1**

If one root of a equation is $2 + \sqrt{5}$, then the quadratic equation is :

(a) $x^2 + 4x - 1 = 0$

(b) $x^2 - 4x - 1 = 0$

(c) $x^2 + 4x + 1 = 0$

(d) None of these

Answer: b**Explanation:**

One root of the equation is $2 + \sqrt{5}$. So, the next root will be $2 - \sqrt{5}$

$$\therefore x = 2 + \sqrt{5} \text{ and } x = 2 - \sqrt{5}$$

$$\therefore (x - (2 + \sqrt{5})) (x - (2 - \sqrt{5})) = 0$$

$$\therefore (x^2 + (4 - 5) - 2x - \sqrt{5x} - 2x + \sqrt{5x}) = 0$$
$$\therefore x^2 - 4x - 1 = 0 \text{ is the required quadratic equation.}$$

Question:2

The equation of a line which is perpendicular to $5x - 2y = 7$ and passes through the mid - point of line joining $(2, 7)$ and $(-4, 1)$ is:

- (a) $2x - 5y - 18 = 0$ (b) $2x + 5y + 18 = 0$
(c) $2x + 5y - 18 = 0$ (d) None of these

Answer: c

Explanation:

First let us find out the coordinates of the midpoint of the line joining $(2,7)$ and $(-4,1)$ using midpoint formula and let this point be P.

$$P(x, y) = [(x_1+x_2)/2, (y_1+y_2)/2]$$

$$\Rightarrow P(x,y) = [(2-4)/2, (7+1)/2]$$

$$\Rightarrow P(x, y) = (-1, 4)$$

as we have coordinates of P, to form an equation, we need to get the slope of this line.

Since the line passing through P is perpendicular to the line $5x-2y=7$, we can find the required slope by using the formula $M_1 \times M_2 = -1$, where M_1 is the slope of the given line and M_2 is the slope of the line we are supposed to form an equation for.

to find M_1 , let us rewrite the given equation in $y = M_1X + C$ form.

$$5x - 2y = 7$$

$$\Rightarrow -2y = -5x + 7$$

$$\Rightarrow y = -5x/-2 + 7/(-2)$$

$$\Rightarrow y = 5/2 x - 7/2$$

On comparing this equation with $y = M_1X + c$

We get $M_1 = 5/2$

Now using the equation $M_1 \times M_2 = -1$, we get

$$5/2 \times M_2 = -1$$

$$\text{Therefore } M_2 = -2/5$$

Now as we know M_2 and coordinates of P $(-1,4)$ can use slope point form to get the equation

$$\Rightarrow (y - y_1) = M_2(x - x_1)$$

$$\Rightarrow y - 4 = -2/5(x - (-1))$$

$$\Rightarrow y - 4 = -2/5(x + 1)$$

$$\Rightarrow 5(y - 4) = -2(x + 1) \text{ [by cross multiplication]}$$

$$\Rightarrow 5y - 20 = -2x - 2$$

$$\Rightarrow 2x + 5y - 18 = 0 \text{ is the answer}$$

Question:3

Find the positive value of k for which the equations: $x^2 + kx + 64 = 0$ and $x^2 - 8x + k = 0$ will have real roots:

- (a) 12 (b) 16
(c) 18 (d) 22

Answer: b

Explanation:

For real roots, discriminant = $b^2 - 4ac = 0$

$$\text{For } x^2 + kx + 64 = 0$$

$$= k^2 - 4 \times 1 \times 64 = 0$$

$$\begin{aligned}
 &= k^2 - 256 = 0 \\
 &= k^2 = 256 \\
 &= k = 16 \\
 \text{For } x^2 - 8x + k &= 0 \\
 &= (-8)^2 - 4 \times 1 \times k = 0 \\
 &= 64 - 4k = 0 \\
 &= 4k = 64 \\
 &= k = 16 \\
 \text{Hence, } k &= 16
 \end{aligned}$$

Question:4

A man starts his job with a certain monthly salary and earns a fixed increment every year. If his salary was f 1,500 after 4 years of service and 1,800 after 10 years of service, what was his starting salary and what is the annual increment in rupees?

- (a) 1300, 50 (b) 1100,50
 (c) 1500, 30 (d) None

Answer: a

Solution:

Let the starting salary be x and the annual increment be y. Then, $x + 4y = 1500$
 $x + 10y = 1800$
 Subtracting (1) and (2)
 $x + 10y = 1800$
 $x + 4y = 1500$
 $6y = 300$
 $y = 50$
 Subtracting $y = 50$ in (1), we get $x = 1,300$
 Therefore, starting salary = $x = 1,300$
 Annual increment = $y = 50$.

Question:5

The value of k for which the points (k, 1), (5,5) and (10,7) may be collinear is:

- (a) $k = -5$ (b) $k = 7$
 (c) $k = 9$ (d) $k = 1$

Answer: a

Solution:

The given points are collinear

$$\begin{aligned}
 \Rightarrow & \begin{vmatrix} 5 & 5 & 1 \\ k & 1 & 1 \\ 10 & 7 & 1 \end{vmatrix} = 0 \\
 \Rightarrow & \begin{vmatrix} 5 & 5 & 1 \\ k-5 & -4 & 0 \\ 5 & 2 & 0 \end{vmatrix} = 0 \quad [R_2 \rightarrow R_2 - R_1 \text{ and } R_3 \rightarrow R_3 - R_1] \\
 \Rightarrow & 1 \cdot [2(k-5) + 20] = 0 \\
 \Rightarrow & 2k + 10 = 0 \\
 \Rightarrow & K = -5 \\
 \text{Hence, } k &= -5
 \end{aligned}$$

Question: 6

A man went to the Reserve Bank of India with - 1,000. He asked the cashier to give him Rs.5 and 10 notes only in return. The man got 175 notes in all. Find how many notes of 5 and f 10 did he receive?

- (a) (2, 150) (b) (40, 110)
(c) (150,25) (d) None

Answer: c

Solution:

Let the number of notes of, 5 be x and notes of 10 be y.

$$\text{Then } x + y = 175$$

$$5x + 10y = 1000$$

Solving (1) and (2) simultaneously, we get

$$5x + 5y = 875$$

$$5x + 10y = 1000$$

$$\underline{(-)(-)(-)}$$

$$- 5y = -125$$

$$Y = 25 \quad X = 150$$

Question: 7

If $(2+y\sqrt{3})$ is a root of a quadratic $x^2 + px + q = 0$, then find the value of p and q.

- (a) (4,-1) (b) (4,1)
(c) (-4,1) (d) (2,3)

Answer: c

Solution:

If one of the roots of the quadratic is $2 + \sqrt{3}$, then other root is $2 - \sqrt{3}$

$$\text{Sum of roots} = (2 + \sqrt{3}) + (2 - \sqrt{3}) = 4$$

$$\text{Product of roots} = (2 + \sqrt{3})(2 - \sqrt{3}) = 4 - 3 = 1$$

Required equation is:

$$X^2 - (\text{sum of roots})x + \text{product of roots} = 0$$

$$\text{Or } x^2 - 4x + 1 = 0$$

Now comparing with $x^2 + px + q = 0$

We get, $p = -4$ and $q = 1$

Required answer is (-4,1)

Question: 8

The length of the rectangle is 5 cm more than its breadth if the perimeter of the rectangle is 40 cm find the area of rectangle

- (a) 7.5 cm, 2.5 cm (b) 10 cm, 5cm
(c) 12.5 cm, 7.5 cm (d) 15.5 cm, 10.5cm

Answer: c

Solution:

Let the breadth of the rectangle be x cm.

$$\text{Length} = x + 5 \text{ cm}$$

$$\text{Perimeter} = 2(l + b) =$$

$$2(x + 5 + x) = 4x + 10 \text{ cm}$$

$$4x + 10 = 40$$

$$4x = 30$$

$$X = 30/4 = 7.5$$

So breadth = 7.5 cm; length = 12.5 cm

$$\text{Area} = l \times b = 12.5 \times 7.5 = 93.75$$

$$\text{So area} = 93.75\text{cm}^2$$

Question: 9

A straight line of $x = 15$ is

(a) Parallel to y axis

(b) Parallel to x axis

(c) A diagonal line

(d) Passes through origin

Answer: a

Solution:

A straight line $x = 15$ is parallel to y axis.

The equation clearly depicts that the line passes through the point P (15 , 0).

Question: 10

The point of intersection of the lines $2x - 5y = 6$ and $x + y = 3$

(a) (0,3)

(b) (3 , 0)

(c) (3,3)

(d) (0, 0)

Answer: b

Solution:

$$2x - 5y = 6 \text{ ---- (1)}$$

$$x + y = 3 \text{ (2)}$$

Multiplying eq. (2) by 5 for make be co - efficients of eq. (1) and eq. (2) same, we get :-

$$5x + 5y = 15 \text{ (3)}$$

Adding eq. (1) and eq. (3)

$$2x - 5y = 6$$

$$5x + 5y = 15$$

$$\hline 7x = 21$$

$$x = \frac{21}{7}$$

$$x = 3$$

Substituting the value of x in eq (1)

$$2x - 5y = 6$$

$$2 \times 3 - 5y = 6$$

$$6 - 5y = 6$$

$$5y = 6 - 6$$

$$y = 0$$

Point of intersection is (3, 0).

Question: 11

Find the equation of the line passing through the point (1, 1) and parallel to the line $3x + 5y + 17 = 0$

(a) $3x + 5y + 8 = 0$

(b) $5x + 3y + 8 = 0$

(c) $5x + 3y - 8 = 0$

(d) $3x + 5y - 8 = 0$

Answer: d

Solution:

Let the equation be $3x + 5y + k = 0$. This equation passes through the point (1, 1).

Therefore, substituting (1, 1). Therefore, substituting (1,1) in the equation, we get : $3x$

$$+ 5y + k = 0$$

$$3 \times 1 + 5 \times 1 + k = 0$$

$$3 + 5 + k = 0.$$

$$K = -8$$

So, the equation of the straight line is $3x + 5y - 8 = 0$.

Question: 12

If one root of the equation $x^2 - 3x + k = 0$ is 2, then value of k will be:

- (a) 1 (b) 0
(c) 2 (d) 10

Answer: c

Solution:

$$X^2 - 3x + k = 0$$

$$\text{One root} = 2$$

Putting $x = 2$, we get

$$(2)^2 - 3(2) + k = 0 \Rightarrow 4 - 6 + k = 0$$

$$K = 2$$

Question: 13

If $|x - 2| + |x - 3| = 7$ then, 'x' will be equal to

- (a) 6 (b) -1
(c) 6 and -1 (d) none

Answer: a

Solution:

$$\text{If } |x - 2| + |x - 3| = 7$$

$$\text{If } x - 2 \geq 0 \text{ and } x - 3 \geq 0$$

$$(x - 2) + (x - 3) = 7$$

$$x - 2 + x - 3 = 7$$

$$2x = 7 + 2 + 3$$

$$2x = 12 \Rightarrow x = 6$$

Question: 14

If thrice of A's age 6 years ago be subtracted from twice his present age, the result would be equal to his present age. Find A's present age.

- (a) 9 (b) 10
(c) 11 (d) 12

Answer: a

Solution:

Let x years be A's present age by the question

$$2x - 3(x - 6) = x$$

$$\text{Or } 2x - 3x + 18 = x$$

$$\text{Or } -x + 18 = x$$

$$\text{Or } 2x = 18$$

$$\text{Or } x = 9$$

A's present age is 9 years.

Question: 15

A number consist of two digits the digit in the ten's place is twice the digit in the unit's place. If 18 be subtracted from the number, the digits are reversed. Find the number.

- (a) 40 (b) 42

(c) 39

(d) 21

Answer: b

Solution:

Let x be the digit in the unit's place .so the digit in the ten's Place is 2x. Thus the number becomes $10(2x) + x$. By the question

$$20x + x - 18 = 10x + 2x$$

$$\text{Or } 21x - 18 = 12x$$

$$\text{Or } 9x = 18$$

$$\text{Or } x = 2$$

So the required number is $10(2 \times 2) + 2 = 42$

Question: 16

For a certain commodity the demand 'd' in kg, for a price 'p' in rupees per kg, is $d = 100(10 - p)$. The supply equation giving the supply s in kg. for a price p in rupees per kg . is $s = 75(p - 3)$. The market price is such at which demand equals supply. Find the market price and quantity that will be bought and sold.

(a) 230

(b) 300

(c) 600

(d) 390

Answer: b

Solution:

Given $d = 100(10 - p)$ and $s = 75(p - 3)$

Since the market price is such that demand (d) = supply

(s)

We have $100(10 - p)$ and $s = 75(p - 3)$

$$\text{Or } 1000 - 100p = 75p - 225$$

$$1000 + 225 = 75p + 100p$$

$$1225 = 175p$$

$$P = 7$$

So, market price of the commodity is 7 per kg.

The required quantity bought = $100(10-7) = 300$ kg.

And the quantity sold = $75(7-3) = 300$ kg.

Question: 17

The denominator of a fraction exceeds the numerator by 5 and if 3 be added to both the fraction becomes $\frac{3}{4}$, find the fraction.

(a) $\frac{11}{17}$

(b) $\frac{12}{17}$

(c) $\frac{13}{17}$

(d) $\frac{14}{18}$

Answer: b

Solution:

Let x be the numerator and the fraction be $\frac{x}{x+5}$

By the question $\frac{x+3}{x+5+3} = \frac{3}{4}$ or

$$4x + 12 = 3x + 24 \text{ or } x = 12$$

The required fraction is $\frac{12}{17}$

Question:18

Solve $2x + 5y = 9$ and $3x - y = 5$.

(a) $x = 2, y = 1$

(b) $x = 2, y = 2$

(c) $x = 1, y = 1$

(d) $x = 2, y = 0.$

Answer: a

Solution:

$2x + 5y = 9$ (i)

$3x - y = 5$ (ii)

By making (i) $\times 1$, $2x + 5y = 9$

and by making (ii) $\times 5$, $15x - 5y = 25$

Adding $17x = 34$ or $x = 2$. Subtracting this value of x in (i) i.e. $5y = 9 - 2x$ we find:

$5y = 9 - 4 = 5$

$Y = 1$

$X = 2, y = 1$

Question: 19

The age of a man three times the sum of the ages of his two sons and 5 years hence his age will be double the sum of their ages. Find the present age of the man?

(a) 40 years

(b) 41years

(c) 55 years

(d) 45 years

Answer: d

Solution:

Let x years be the present age of the man and sum of the present ages of the two sons be y years.

By the condition $x = 3y$ (i)

And $x + 5 = 2(y + 5 + 5)$ (ii)

From (i) & (ii) $3y + 5 = 2(y + 10)$

Or $3y + 5 = 2y + 20$

Or $3y - 2y = 20 - 5$

Or $y = 15$

$X = 3 \times y = 3 \times 15 = 45$

Hence the present age of the main is 45 years

Question: 20

Examine the nature of the roots of the following equations $x^2 - 8x + 16 = 0$

(a) roots are real and equal

(b) roots are real, rational and unequal

(c) roots are imaginary and unequal

(d) roots are real irrational and unequal

Answer: a

Solution:

$a = 1, b = -8, c = 16$

$b^2 - 4ac = (-8)^2 - 4.1.16 = 64 - 64 = 0$

The roots are real and equal.

Question: 21

Two times a number, decreased by 12 equals three times the number, decreased by 15. Which is the number?

(a) 3

(b) -62

(b) -64

(d) 6

Answer: a

Solution:

Let us denote the number with n. We rewrite the problem as $2n-12=3n-15$. We subtract $2n$ from both sides and get $-12=n-15$. Then we add 15 to both sides in order to get $n=3$.

Question: 22

The roots of a quadratic equation:

- (a) $\frac{-b \pm \sqrt{b^2 - 4ac}}{2a}$ (b) $\frac{b \pm \sqrt{b^2 - 4ac}}{2a}$
 (c) Either a or b (d) None

Answer: a

Solution:

The nature of the roots α and β of equation $ax^2+bx+c=0$ depends on the quantity or expression $(b^2 - 4ac)$ under the square root signHence the expression $(b^2 - 4ac)$ is called the discriminant of the quadratic equation $\frac{-b \pm \sqrt{b^2 - 4ac}}{2a}$

Question:23

Which of the following is correct?

- I. If $b^2-4ac = 0$ the roots are real and equal;
- II. If $b^2-4ac > 0$ then the roots are imaginary;
- III. If $b^2-4ac < 0$ then the roots are equal;
- IV. If b^2-4ac is a perfect square (0) the roots are real, rational and unequal
- V. If $b^2-4ac > 0$ but not a perfect square the roots are real, irrational and unequal.

- (a) All the correct (b) ii & iii
 (c) all are correct expect ii & iii (d) i& iii & iv is correct

Answer: c

Solution:

- I. If $b^2-4ac = 0$ the roots are real and equal
 - II. If $b^2-4ac > 0$ then the roots are real and unequal (or distinct);
 - III. If $b^2-4ac < 0$ then the roots are imaginary;
 - IV. If b^2-4ac is a perfect square (0) the roots are real, rational and unequal (distinct);
 - v. If $b^2-4ac > 0$ but not a perfect square the roots are real, irrational and unequal
- Since b^2-4ac discriminates the roots b^2-4ac is called the discriminant in the equations $ax^2 + bx + c = 0$ as it actually discriminates between the roots.

Question: 24

Find the roots of the quadratic equation: $x^2 + 2x - 15 = 0$?

- (a) 5, 3 (b) 3,-5
 (c) -3 ,5 (d) -3, -5

Answer: b

Solution:

$$X^2 + 5x - 3x - 15 = 0$$

$$X(x + 5) - 3(x + 5) = 0$$

$$(x - 3)(x + 5) = 0$$

$$\Rightarrow x = 3 \text{ or } x = -5.$$

Question: 25

The sum of the squares of two consecutive positive integers exceeds their product by 91. Find the integers?

- (a) 9, 10 (b) 10, 11
(c) 11, 12 (d) 12, 13

Answer: a

Solution:

Let the two consecutive positive integers be x and $x + 1$

$$x^2 + (x + 1)^2 - x(x + 1) = 91$$

$$x^2 + x - 90 = 0$$

$$(x + 10)(x - 9) = 0 \Rightarrow x = -10 \text{ or } 9.$$

As x is positive $x = 9$

Hence the two consecutive positive integers are 9 and 10.

Question: 26

A number is equal to 4 times this number less 75. What is the number?

- (a) 15 (b) 35
(c) 25 (d) 20

Answer: c

Solution:

Let us denote the number with n . The problem can be rewritten as $n = 4n - 75$. By subtracting n from both sides, we get $3n - 75 = 0$. Now we divide both sides by 3 to get $n - 25 = 0$, or $n = 25$.

Question: 27

If $\sqrt{3 - 2x} + \sqrt{7 + 2x} = 4$, then find the positive value of x ?

- (a) -3, 1 (b) 3, -1
(c) 3, -2 (d) 3, 2

Answer: a

Solution:

$$\text{Given, } \sqrt{3 - 2x} + \sqrt{7 + 2x} = 4$$

$$\text{Or, } \sqrt{3 - 2x} = 4 - \sqrt{7 + 2x}$$

Squaring on both sides, we get

$$(\sqrt{3 - 2x})^2 = (4 - \sqrt{7 + 2x})^2$$

$$\rightarrow 3 - 2x = 16 + 7 + 2x - 8\sqrt{7 + 2x}$$

$$\rightarrow 4x + 20 = 8\sqrt{7 + 2x}$$

$$\rightarrow x + 5 = 2\sqrt{7 + 2x}$$

Again squaring on both sides, we get

$$(x + 5)^2 = (2\sqrt{7 + 2x})^2$$

$$\rightarrow x^2 + 10x + 25 = 4(7 + 2x)$$

$$\rightarrow x^2 + 10x + 25 = 28 + 8x$$

$$\rightarrow x^2 + 2x - 3 = 0$$

$$\rightarrow x^2 + 3x - x - 3 = 0$$

$$\rightarrow (x + 3)(x - 1) = 0$$

$$\rightarrow x = -3 \text{ or } x = 1$$

Possible value of $x = 1, -3$

Hence, A is the correct option.

Question: 28

I. $a^2 + 11a + 30 = 0$

II. $b^2 + 6b + 5 = 0$ to solve both the equations to find the values of a and b?

(a) If $a < b$

(b) If $a \leq b$

(c) If the relationship between a and b cannot be established

(d) If $a > b$

Answer: b

Solution:

(i) $(a+6)(a+5) = 0$

$a = -6, -5$

(ii) $(b+5)(b+1) = 0$

$b = -5, -1 \Rightarrow a \leq b$

Question: 29

A number is equal to 7 times itself minus 18. Which is the number?

(a) -3

(b) 3

(c) 2

(d) -2

Answer: b

Solution:

The statement is equivalent to the following equation:

$X = 7x - 18x$

$18 = 7x - x$

$6x = 18$

$X = 3$

Question: 30

If a and b are the roots of the equations $x^2 - 9x + 20 = 0$, find the value of $a^2 + b^2 + ab$

(a) -21

(b) 1

(c) 61

(d) 21

Answer: c.

Solution:

$a^2 + b^2 + ab = a^2 + b^2 + 2ab - ab$

i.e., $(a + b)^2 - ab$

from $x^2 - 9x + 20 = 0$, we have

$a + b = 9$ and $ab = 20$. Hence the value of required expression $(9)^2 - 20 = 61$.

Question: 31

If $a + b = 29$, $b + c = 45$, $a + c = 44$. Find $a + b + c$?

(a) -21

(b) 1

(c) 59

(d) 118

Answer: c

Solution:

$(a + b) + (b + c) + (a + c) = 29 + 45 + 44$

$a + b + b + c + a + c = 118$

$2a + 2b + 2c = 118$

$2(a + b + c) = 118$

$a + b + c = 59$

Question: 32

A simple equation in one unknown x is in form $ax + b = 0$. Is true or not?

- (a) true (b) false
(c) not sure (d) partial

Answer: a

Solution:

A simple equation in one unknown x is in the form $ax + b = 0$. Where a, b are known constants and $a \neq 0$

Question: 33

If both the roots of $k(6x^3 + 3) + rx + 2x^2 - 1 = 0$ and $6k(2x^2 + 1) + px + 4x^2 - 2 = 0$ are common, then $2r - p$ is equal to

- (a) -1 (b) 0
(c) 1 (d) 2

Answer: b

Solution:

The two equations can be written as

$$x^2(6k + 2) + rx + (3k - 1) = 0 \quad \dots (1)$$

$$\text{and } x^2(12k + 4) + px + (6k - 2) = 0 \quad \dots (2)$$

Divide by 2

$$\therefore x^2(6k + 2) + \frac{p}{2}x + (3k - 1) = 0 \quad \dots (3)$$

Comparing (1) and (3), we get $r = \frac{p}{2}$

$$\therefore 2r - p = 0.$$

Question: 34

If a root of the equations $x^2 + px + q = 0$ and $x^2 + \alpha x + \beta = 0$ is common then its value will be (where $p \neq \alpha$ and $q \neq \beta$) Condition for common roots is $\frac{12k+4}{6k+2} = \frac{p}{e}$

- (a) $\frac{q-\beta}{\alpha-p}$ (b) $\frac{p\beta-\alpha q}{q-\beta}$
(c) $\frac{q-\beta}{\alpha-p} - \frac{p\beta-\alpha q}{q-\beta}$ (d) None

Answer: b

Solution:

Let the common root be y . Then $y^2 + py + q = 0$ and $y^2 + \alpha y + \beta = 0$ on solving by cross multiplication, we have $\frac{y^2}{p\beta - q\alpha} = \frac{y}{q - \beta} = \frac{1}{\alpha - p} \implies y = \frac{q - \beta}{\alpha - p}$ and $\frac{y^2}{y} = y = \frac{p\beta - q\alpha}{q - \beta}$

Question: 35.

If the two equations $x^2 - cx + d = 0$ and $x^2 - ax + b = 0$ have one common root and the second has equal roots then $2(b + d) =$

- (a) $a + c$ (b) 0
(c) ac (d) $-ac$

Answer: c

Solution:

Given quadratic equations

$$x^2 - cx + d = 0 \quad \dots (1)$$

Let α, β be the roots of equation (1)

$$x^2 - ax + b = 0 \quad \dots (2)$$

Let α, α be the roots of equation (2)

$$2\alpha = a$$

$$\alpha = \frac{a}{2}$$

$$\text{Also, } \alpha^2 = b$$

Since, α is a root of (1),

$$\alpha^2 - c\alpha + d = 0$$

$$b + d = \frac{ac}{2}$$

$$2(b + d) = ac$$

Question: 36.

If $x^2 - hx - 21 = 0, x^2 - 3hx + 35 = 0 (h > 0)$ has a common root then, the value of h is equal to

- (a) 1 (b) 2
(c) 3 (d) 4

Answer: d

Solution:

Subtracting we get $2hx = 56$ or $hx = 28$ putting in any,

$$x^2 - 3(28) + 35 = 0$$

$$x^2 - 84 + 35 = 0$$

$$x^2 = 49$$

$$X = 7$$

$$hx = 28$$

$$h = 4$$

Question:37

If Every pair of the equations $x^2 + px + qr = 0, x^2 + qx + rp = 0, x^2 + rx + pq = 0$ have a common root. Then the sum of three common roots is

- (a) $\frac{-(p+q+r)}{2}$ (b) $\frac{-(p-q+r)}{2}$
(c) $-(p+q+r)$ (d) $-p+q+r$

Answer: a

Solution:

Let the roots be $(\alpha, \beta), (\beta, \lambda)$ and (λ, α) respectively

$\alpha + \beta = -p, \beta + \lambda = -q, \lambda + \alpha = -r$ adding all, we get $\sum\alpha = -(p + q + r) / 2$ etc.

Question: 38

If the equation $x^2 + px + q = 0$ and $x^2 + qx + p = 0$, have a common root, then $p + q + 1$

- (a) 0 (b) 1
(c) 2 (d) -1

Answer: a

Solution:

Let α is the common root, so $\alpha^2 + p\alpha + q = 0 \dots(i)$ and $\alpha^2 + q\alpha + p = 0 \dots (ii)$

From (i) - (ii), $\Rightarrow (p - q)\alpha + (q - p) = 0 \Rightarrow \alpha = 1$ put the value of α in (i), $p + q + 1 = 0$

Question: 39

If $x^2 + \alpha x + 10 = 0$ and $x^2 + bx - 10 = 0$ have a common root, then, $a^2 - b^2$ is equal to

- (a) 10 (b) 20
(c) 30 (d) 40

Answer: d

Solution:

Let α be a common root, then $\alpha^2 + \alpha\alpha + 10 = 0$ (i) and $\alpha^2 + b\alpha - 10 = 0$

?... (ii) form (i) - (ii), $(a - b)\alpha + 20 = 0 \Rightarrow \alpha = -\frac{20}{a-b}$ substituting the value of α

(i).

We get $\left(-\frac{20}{a-b}\right)^2 + a\left(-\frac{20}{a-b}\right) + 10 = 0 \Rightarrow 400 - 20a(a-b) + 10(a-b)^2 = 0$

$\Rightarrow 40 - 2a^2 + 2ab + a^2 + b^2 - 2ab = 0 \Rightarrow a^2 - b^2 = 40.$

Question: 40

$x^2 - 11x + a$ and $x^2 - 14x + 2a$ will have a common factor, if $a = 42$

- (a) 24 (b) 0, 24
(c) 3, 24 (d) 0, 3

Answer: b

Solution:

Expression are $x^2 - 11x + a$ and $x^2 - 14x + 2a$ will have a common factor, then

$\Rightarrow \frac{x^2}{-22a+14a} = \frac{x}{a-2a} = \frac{1}{-14+11} \Rightarrow \frac{x^2}{-8a} = \frac{1}{-3} \Rightarrow x^2 = \frac{8a}{3}$ and $x = \frac{a}{3}$

$\left(\frac{a}{3}\right)^2 = \frac{8a}{3} \Rightarrow \frac{a^2}{9} = \frac{8a}{3}$ $pa = 0, 24.$ Trick we can check by putting the values of a from the options.

Question: 41

If x be real, then the minimum value of $x^2 - 8x + 16$ is.

- (a) -1 (b) 0
(c) 1 (d) 2

Answer: c

Solution:

$[x^2 - 8x + 16]$ since x is real, so $(x - 4)^2$ is always positive and its least value is 0 and so the minimum value of given expression is 1.

Question: 42

Solve the equations $8+2(x-4) = 16$

- (a) -1 (b) 8
(c) 10 (d) 2

Answer: b

Solution:

First, we removed the parentheses and get $8 + 2(x - 4) = 16$, or $8 + 2x - 8 = 16$, which gives us $2x=16$. We divide by 2 in order to get $x = 8$.

Question: 43

Solve the equation: $x^3 + 10 = 2x$ $x^3 + 10 = 2x$.

- (a) 6 (b) 8
(c) 10 (d) 2

Answer: a

Solution:

We multiply both sides by 3 to get free of the denominator. This gives us $x+3-10=3.2x$, or $x+30=6x$ by subtracting x from both sides we get $30=5x$. Dividing both sides by 5 gives us the answer, $x = 6$.

Question: 44

$$2(3x - 7) + 4(3x+2) = 6(5x+9)$$

- (a) 6 (b) -5
(c) 10 (d) 2

Answer: b

Solution:

$$\begin{aligned} 2(3x-7)+4(3x+2) &= 6(5x+9) \\ 6x - 14 + 12x + 8 &= 30x + 54 \\ 6x + 12x - 30x &= 14 - 8 + 54 \\ -12x &= 60 \\ X = 60 \div (-12) &= -5 \end{aligned}$$

Question: 45

Find the solution x to the equations $x^3-x^4=2 \times 3-x^4=2$.

- (a) 69 (b) 51
(c) 0 (d) 24

Answer: d

Solution:

We first find the lowest common multiple of 4 and 3. It is 12. Multiplying both sides by 12 gives us $x^3 \cdot 12 - x^4 \cdot 12 = 2 \cdot 12 \times 3 - x^4 \cdot 12 = 2 \cdot 12$, or $4x - 3x = 24$, which means that $x = 24$.

Question: 46

A number, multiplied by 5, equals itself minus 48. Which is the number

- (a) 6 (b) -5
(c) 0 (d) -12

Answer: d

Solution:

$$\begin{aligned} 5x &= x - 48 \\ 4x &= -48 \\ X &= -12 \end{aligned}$$

PAST EXAMINATION QUESTIONS:

MAY 2018

Question: 1

The value of K for which the points $(k, 1)$, $(5,5)$ and $(10,7)$ may be collinear is

- (a) $k = -5$ (b) $k = 7$
(c) $k = 9$ (d) $k = 1$

Answer: a

Solution:

Let $A(x_1, y_1) = (k, 1)$,
 $B(x_2, y_2) = (5, 5)$, and
 $C(x_3, y_3) = (10, 7)$ are three collinear points

Area of triangle ABC = 0

$$\frac{1}{2} |x_1(y_2 - y_3) + x_2(y_3 - y_1) + x_3(y_1 - y_2)| = 0$$

$$|x_1(y_2 - y_3) + x_2(y_3 - y_1) + x_3(y_1 - y_2)| = 0$$

$$\Rightarrow |k(5 - 7) + 5(7 - 1) + 10(1 - 5)| = 0$$

$$\Rightarrow |-2k + 5 \times 6 + 10(-4)| = 0$$

$$\Rightarrow |-2k + 30 - 40| = 0$$

$$\Rightarrow |-2k + 10| = 0$$

$$\Rightarrow -2k = 10$$

$$\Rightarrow k = \frac{10}{-2}$$

$$\Rightarrow k = -5$$

Therefore,

Value of k = -5

Question: 2

If $\alpha + \beta = -2$ and $\alpha\beta = -3$, then α, β are two roots of the equations, which is:

(a) $x^2 - 2x - 3 = 0$

(b) $x^2 + 2x - 3 = 0$

(c) $x^2 + 2x + 3 = 0$

(d) $x^2 - 2x + 3 = 0$

Answer: b

Solution:

If $\alpha + \beta = -2$

Q.E. is

$$X^2 - (\alpha + \beta)x + \alpha\beta = 0$$

$$X^2 - (-2)x + (-3) = 0$$

$$X^2 + 2x - 3 = 0$$

Question: 3

If $2^{x+y} = 2^{2x-y} = \sqrt{8}$, then the respective values of x and y are

(a) $1, \frac{1}{2}$

(b) $\frac{1}{2}, 1$

(c) $\frac{1}{2}, \frac{1}{2}$

(d) None

Answer: a

Solution:

$$2^{x+y} = 2^{2x-y} = \sqrt{8}$$

$$2^{x+y} = \sqrt{8} \quad \text{and} \quad 2^{2x-y} = \sqrt{8}$$

$$2^{x+y} = (2^3)^{1/2} \quad 2^{2x-y} = (2^3)^{1/2}$$

$$2^{x+y} = 2^{3/2} \quad 2^{2x-y} = 2^{3/2}$$

On Comparing

$$x + y = 3/2 \quad \text{----- (1)}$$

Add: (1) & (2)

$$x + y = \frac{3}{2} \quad \text{----- (1)}$$

$$2x - y = \frac{3}{2} \quad \text{----- (2)}$$

$$3x = 3$$

$$x = 1$$

Putting $x = 1$ in equation (1)

$$X + y = \frac{3}{2}$$

$$1 + y = \frac{3}{2}$$

$$Y = \frac{1}{2}$$

$$X = 1, y = \frac{1}{2}$$

Question: 4

The triangle formed by lines $x+2y=3$, $2x-y=1$ and $y=0$ is

- (a) Right angled (b) Equilateral
(c) Isosceles (d) None

Answer: a

Solution:

Given Equation

$$X + 2y = 3 \text{ ----- (1)}$$

$$2x - y = 1 \text{ ----- (2)}$$

$$Y = 0 \text{ ----- (3)}$$

Slope of line (1) is

$$m_1 = \frac{\text{Coefficient of } x}{\text{coefficient of } y} = \frac{-1}{2}$$

Slope of line (2) is

$$m_2 = \frac{\text{coefficient of } x}{\text{coefficient of } y} = \frac{-2}{-1} = 2$$

$$m_1 \times m_2 = -\frac{1}{2} \times 2$$

$$m_1 \times m_2 = -1$$

Both lines are 1 or to each triangle are also perpendicular.

Question: 5

If $\frac{3}{x+y} + \frac{2}{x-y} = -1$ and $\frac{1}{x+y} - \frac{1}{x-y} = \frac{4}{3}$ then x, y is:

- (a) (2, 1) (b) (-1, 2)
(c) (1, 2) (d) None

Answer: c

Solution:

$$\text{If } \frac{3}{x+y} + \frac{2}{x-y} = -1 \text{ and } \frac{1}{x+y} - \frac{1}{x-y} = \frac{4}{3}$$

By hits and trial (1, 2) satisfied both equation so answer is (1, 2)

Question: 6

If the sides of an equilateral triangle are shortened by 3 units, 4 units and 5 units respectively and a right triangle is formed then the sides of equilateral triangle is:

- (a) 6 units (b) 7 units
(c) 8 units (d) 10units

Answer: c

Solution:

Let the side of equilateral triangle is x

In $\triangle ABC$

$$\begin{aligned}(\text{hypo})^2 &= (\text{Base})^2 + (\text{per})^2 \\(x-3)^2 &= (x-4)^2 + (x-5)^2 \\X^2 + 9 - 6x &= x^2 + 16 - 8x + x^2 + 25 - 10x \\X^2 - 18x + 41 + 6x - 9 &= 0 \\X^2 - 12x + 32 &= 0 \\X^2 - 8x - 4x + 32 &= 0 \\X(x-8) - 4(x-8) &= 0 \\(x-8)(x-4) &= 0 \\X-8=0 \text{ if } x-4=0 \\X=8 \text{ and } x=4 \text{ Impossible side of the triangle is } 8\end{aligned}$$

Question: 7

IF α, β are the roots of equation $x^2 + x + 5 = 0$ then $\frac{\alpha^2}{\beta} + \frac{\beta^2}{\alpha}$ is equal to

- (a) $\frac{16}{5}$ (b) 2
(c) 3 (d) $\frac{14}{5}$

Answer: d

Solution:

Given equation:

$$x^2 + x + 5 = 0$$

$$a=1, b=1, c=5$$

if α & β are root of equation

$$\alpha + \beta = \frac{-b}{a} = \frac{-1}{1} = -1$$

$$\alpha\beta = \frac{c}{a} = \frac{5}{1} = 5$$

$$\frac{\alpha^2}{\beta} + \frac{\beta^2}{\alpha} = \frac{\alpha^3 + \beta^3}{\alpha\beta} = \frac{(\alpha + \beta)^3 - 3\alpha\beta(\alpha + \beta)}{\alpha\beta}$$

$$\frac{(-1)^3 - 3 \times 5 \times (-1)}{5}$$

$$\frac{-1 + 15}{5} = \frac{14}{5}$$

NOV 2018

Question: 1

Let α and β be the roots of $x^2 + 7x + 12 = 0$. Then the value of $\frac{\alpha^2}{\beta} + \frac{\beta^2}{\alpha}$ will be

- (a) $\frac{7}{12} + \frac{12}{7}$ (b) $\frac{49}{144} + \frac{144}{49}$
(c) $-\frac{91}{21}$ (d) None

Answer: c

Solution:

If α & β are the roots of equation

$$X^2 + 7x + 12 = 0$$

$$\text{Then } \alpha + \beta = \frac{-b}{a} = \frac{-7}{1} = -7$$

$$\alpha \times \beta = \frac{c}{a} = \frac{12}{1} = 12$$

$$\frac{\alpha^2}{\beta} + \frac{\beta^2}{\alpha} = \frac{\alpha^3 + \beta^3}{\alpha\beta}$$

$$\frac{(\alpha+\beta)^3 - 3\alpha\beta(\alpha+\beta)}{\alpha\beta} = \frac{(-7)^3 - 3 \times 12(-7)}{12}$$

$$\frac{-343+252}{\frac{12}{-91}} = \frac{12}{12}$$

Question: 2

When two roots of quadratic equation are $\alpha, \frac{1}{\alpha}$ then what will be the quadratic equation:

- (a) $ax^2 - (a^2 + 1)x + a = 0$ (b) $ax^2 - (a^2x + 1) = 0$
 (c) $ax^2 - (a^2 + 1)x + 1 = 0$ (d) None

Answer: a

Solution:

If roots of Q.E. are $\alpha, \frac{1}{\alpha}$ then $\alpha + \frac{1}{\alpha} = a, \alpha \cdot \frac{1}{\alpha} = 1$

Sum of roots (S) = $\alpha + \frac{1}{\alpha}$

$$= a + \frac{1}{a} = 1$$

Product of Roots (P) = $\alpha \cdot \frac{1}{\alpha}$

$$= a \cdot \frac{1}{a} = 1$$

Q.E. is given by

$$X^2 - 5x + p = 0$$

$$X^2 - \left[\frac{a^2+1}{a}\right]x + 1 = 0$$

$$ax^2 - (a^2 + 1)x + a = 0$$

MAY 2019

Question: 1

Find the condition that one roots is double the other of $ax^2 + bx + c = 0$

- (a) $2b^2 = 3ac$ (b) $b^2 = 3ac$
 (c) $2b^2 = 9ac$ (d) $2b^2 > 9ac$

Answer: c

Explanation:

Let m be the one root of the given equation

Then the other root will be 2m.

Then $m + 2m = -b/a$ or, $3m = -b/a$ or, $m = -b/3a$.

Now, $m(2m) = c/a$ or, $(-b/3a)(-2b/3a) = c/a$ or, $2b^2 = 9ac$.

Question: 2

$$\begin{pmatrix} x+y & 1 \\ 1 & x-y \end{pmatrix} + \begin{pmatrix} 2 & 3 \\ 2 & -4 \end{pmatrix} = \begin{pmatrix} 12 & 4 \\ 3 & 0 \end{pmatrix} \text{ then}$$

- (a) $x = 7, y = -3$ (b) $x = -7, y = -3$
 (c) $x = -7, y = 3$ (d) $x = 7, y = 3$

Answer: d

Explanation:

By option method, Taking D as option

$$\begin{pmatrix} 7+3 & 1 \\ 1 & 7-3 \end{pmatrix} + \begin{pmatrix} 2 & 3 \\ 2 & -4 \end{pmatrix}$$

$$\begin{pmatrix} 10 & 1 \\ 1 & 4 \end{pmatrix} + \begin{pmatrix} 2 & 3 \\ 2 & -4 \end{pmatrix} = \begin{pmatrix} 12 & 4 \\ 3 & 0 \end{pmatrix}$$

NOV 2019

Question: 1

Roots of the equation $x^3+9x^2-x-9=0$

(a) 1, 2, 3

(b) 1, -1, -9

(c) 2, 3, -9

(d) 1, 3, 9

Answer:(b)

Solution:

$$x^3 + 9x^2 - x - 9 = 0$$

By factorization method

$$X^2(x+9)-1(x+9) = 0$$

$$(x^2 - 1) (x + 9) = 0$$

$$(x + 1) (x - 1) (x - 9) = 0$$

$$(x + 1) = 0 \quad (x - 1) = 0$$

$$X = -1 \quad x = 1$$

$$[a^2-b^2 = (a + b) (a - b)]$$

$$(x+9) = 0$$

$$x = -9$$

Question: 2

$$\frac{2x+5}{10} + \frac{3x+10}{15} = 5$$

(a) 10.58

(b) 9.58

(c) 9.5

(d) None

Answer:(b)

Solution:

$$\frac{2x+5}{10} + \frac{3x+10}{15} = 5$$

$$\frac{15(2x+5)+10(3x+10)}{150} = 5$$

$$30x + 75 + 30x + 100 = 750$$

$$60x = 575$$

$$X = \frac{575}{60}$$

$$X = 9.58(\text{approx})$$

Question: 3

Find value of $x^2-10x + 1$ if $x = \frac{1}{5-2\sqrt{6}}$

(a) 25

(b) 1

(c) 0

(d) 49

Answer:(c)

Solution:

$$x^2 - 10x + 1 = 0 \Rightarrow \text{give equation}$$

$$X = \frac{1}{5-2\sqrt{6}}$$

Multiplying by conjugate

$$X = \frac{1}{5-2\sqrt{6}} \times \frac{5+2\sqrt{6}}{5+2\sqrt{6}}$$

$$X = \frac{5+2\sqrt{6}}{(5)-(2\sqrt{6})} (a + b) (a - b) = a^2 - b^2$$

$$X = \frac{5+2\sqrt{6}}{25-24}$$

$$X = 5 + 2\sqrt{6}$$

$$X^2 = (5 + 2\sqrt{6})^2 = a^2 + b^2 + 2ab$$

$$= 25 + 24 + 2 \times 5 \times 2\sqrt{6}$$

$$X^2 = 49 + 20\sqrt{6} \text{ ----- (1)}$$

$$10x = 10(5 + 2\sqrt{6}) = 50 + 20\sqrt{6} \text{ ----- (2)}$$

$$X^2 - 10x + 1$$

$$= 49 + 20\sqrt{6} - 50 - 20\sqrt{6} + 1 \text{ {from equation ---- (1) \& (2)}$$

$$= 0$$

So, $x^2 - 10x + 1 = 0$

Question: 4

Find the value of k in $3x^2 - 2kx + 5 = 0$

If $x = 2$

- | | |
|----------|-----------|
| (a) 15 | (b) -7/14 |
| (c) 17/4 | (d) -4/17 |

Answer: (c)

Solution:

$3x^2 - 2kx + 5 = 0$ { give equation } as it is given $x = 2$

Then put in place of $x = '2'$

$$3 \times (2)^2 - 2k(2) + 5 = 0$$

$$3 \times 4 - 2k(2) + 5 = 0$$

$$12 - 4k + 5 = 0$$

$$-4k = -12 - 5$$

$$-4k = -17$$

$$K = \frac{17}{4}$$

DEC 2020

Question 1

If $2x^2 - (a + 6)2x + 12a = 0$ then roots are

- | | |
|------------------------|------------|
| (a) 4 & a ² | (b) 6 & a |
| (c) 3 & 2a | (d) 6 & 3a |

Answer: b

Explanation:

Given:

$$2x^2 - (a + 6)2x + 12a = 0$$

$$\Rightarrow 2x^2 - 2ax - 12x + 12a = 0$$

$$\Rightarrow 2x(x - a) - 12(x - a) = 0$$

$$\Rightarrow (2x - 12)(x - a) = 0$$

On equation both the factors with '0' we get

$$\Rightarrow 2x - 12 = 0 \quad \rightarrow x - a = 0$$

$$\Rightarrow 2x = 12 \quad \rightarrow x = a$$

$$\Rightarrow X = 6$$

∴ Two roots are 6 and a

∴ Option B is the correct answer.

Question 2

Solving equation $3g^2 - 14g + 16 = 0$, we get roots as

(a) 0

(c) 8 and $\frac{2}{3}$

(b) ± 5

(d) 2 and $\frac{8}{3}$

Answer: d

Explanation:

By option d

Putting value 2

$$3 \times 2^2 - 14(2) + 16 = 0$$

$$0=0$$

putting value $\frac{8}{3}$

$$3 \times \left(\frac{8}{3}\right)^2 - 14 \times \frac{8}{3} + 16$$

$$0=0$$

Question 3

Solving equations $m + \sqrt{m} = \frac{6}{25}$ the value of $\sqrt{m} = \frac{6}{25}$ the value of 'm' works out to works out to:

(a) $\frac{2}{25}$

(b) $\frac{1}{25}$

(c) $\frac{3}{25}$

(d) 1

Answer: b

Explanation:

Correct option is B $\frac{1}{25}$

$$m + \sqrt{m} = \frac{6}{25}$$

let $m = t^2$

$$\therefore t^2 + t = \frac{6}{25}$$

$$\Rightarrow 25t^2 + 25t - 6 = 0$$

$$\Rightarrow t = \frac{-25 \pm \sqrt{625 + 4 \times 25 \times 6}}{2 \times 25}$$

$$t = \frac{-25 \pm \sqrt{1225}}{50}$$

$$t = \frac{-25 \pm 35}{50}$$

$$t = \frac{10}{50} \text{ and } t = \frac{-60}{50}$$

$\therefore, t = \frac{1}{5}$ is correct answer

$$\text{Now, } m = t^2 = \frac{1}{25}$$

$\therefore, \text{Option B is correct.}$

JULY 2021

Question 1

If α and β are the roots of the equation $2x^2 + 5x + k = 0$, and $4(\alpha^2 + \beta^2 + \alpha\beta) = 23$, then which of the following is true?

(a) $k^2 + 3k - 2 = 0$

(b) $k^2 - 2k + 3 = 0$

(c) $k^2 - 2k - 3 = 0$

(d) $k^2 - 3k + 2 = 0$

Answer: Options (d)

Question 2

The cost of 2 oranges and 3 apples is ₹ 28. If the cost of an apple is doubled then the cost of 3

oranges and 5 apples is ₹ 75. The original cost of 7 oranges and 4 apples (in ₹) is.

- (a) 59 (b) 47
(c) 71 (d) 63

Answer: Options (a)

Question 3

The value of 'K' is _____, if 2 is a root of the following cubic equation: $x^3 - (k+1)x + k = 0$

- (a) 2 (b) 6
(c) 1 (d) 4

Answer: Options (b)

Question 4

The sum of square of any real positive quantities and its reciprocal is never less than

- (a) 1 (b) 2
(c) 3 (d) 4

Answer: Options (b)

Explanation:

Let the positive real number be a then its reciprocal will be $\frac{1}{a}$.

So using property $AM \geq GM$ we could say that

$$\frac{a + \frac{1}{a}}{2} \geq \sqrt{a \times \frac{1}{a}} \text{ Or}$$

$$\left(a + \frac{1}{a}\right) \geq 2 \times 1$$

$$\text{Therefore } \left(a + \frac{1}{a}\right) \geq 2.$$

Question 4

If $A = \begin{bmatrix} 1 & 0 \\ -1 & 1 \end{bmatrix}$ then the value of A^5 is

- (a) $\begin{bmatrix} 1 & 0 \\ -1 & 5 \end{bmatrix}$ (b) $\begin{bmatrix} 1 & 0 \\ 0 & 1 \end{bmatrix}$
(c) $\begin{bmatrix} 1 & 0 \\ -5 & 1 \end{bmatrix}$ (d) $\begin{bmatrix} 1 & -5 \\ 0 & 1 \end{bmatrix}$

Answer: Options (c)

DEC 2021

Question 1

If one root is half of the other of a quadratic equation and the difference in roots is a , then the equation is

- (a) $x^2 + ax + 2a^2 = 0$ (b) $x^2 - 3ax - 2a^2 = 0$
(c) $x^2 - 3ax + 2a^2 = 0$ (d) $x^2 + 3ax - 2a^2 = 0$

Answer:

Explanation:

Let one root be a , and another root be $\frac{1}{2} \times a = \frac{a}{2}$. Since one root is half of the other root, we have $p = \frac{a}{2}$ } $a = g$ Since the difference of the roots is a , we have:

$$a - \frac{a}{2} = a$$

$$\frac{2\alpha - \alpha}{2} = a$$

$$\frac{\alpha}{2} = a$$

$$\alpha = 2a$$

$$\text{Therefore, } \beta = \frac{\alpha}{2} = \frac{2a}{2} = a$$

$$\text{Sum of roots} = 2a \times a = 2a^2$$

When the roots are known, the equation is given by:

$$x^2 - (\text{Sum of Roots})x + \text{Product of Roots} = 0$$

Therefore, the equation is:

$$x^2 - 3ax + 2a^2 = 0$$

Question 2

In a multiple choice question paper consisting of 100 questions of 1 mark each, a candidate gets 60% marks. If the candidate attempted all wrong answer, the difference between number of right answers questions and there was a penalty of 0.25 marks for and wrong answers is:

(a) 32

(b) 36

(c) 40

(d) 38

Answer:

Explanation:

Let the number of right answers be x ; then the number of wrong answers be $100 - x$. Total marks = 60

$$(1 \times x) - 0.25(100 - x) = 60$$

$$= x - (25 - 0.25x) = 60$$

$$-x - 25 + 0.25x = 60$$

$$= 1.25x = 60 + 25$$

$$= 1.25x = 85$$

$$x = \frac{85}{1.25} = 68$$

Therefore, the number of correct answers = 68.

Hence, the number of wrong answers = $100 - 68 = 32$.

Therefore, the difference between the correct answers and wrong answers = $68 - 32 = 36$.

Question 3

If the square of a number exceeds twice of the number by 15, then number that satisfies the condition is

(a) -5

(b) 3

(c) 5

(d) 15

Answer: c

Explanation:

Let the number be x .

As per the question, $x^2 - 2x = 15$

Now, try the options.

Option (a) = -5

$$\text{LHS} = (-5)^2 - 2(-5) = 25 + 10 = 35 \neq \text{RHS}$$

Option (b) = 3

$$\text{LHS} = (3)^2 - 2(3) = 9 - 6 = 3 = \text{RHS}$$

Option (c) = 5

$$\text{LHS} = (5)^2 - 2(5) = 25 - 10 = 15 = \text{RHS}$$

Therefore, option (c) is the answer.

Question 4

Solve $x^3 - 7x + 6 = 0$

(a) $x = 6, 7, -4$

(b) $x = -1, -2, -3$

(c) $x = 1, 2, -3$

(d) $x = 2, 4, 6$

Answer:

Solve $x^3 - 7x + 6 = 0$

$$x^3 - x^2 + x^2 - 7x + 6 = 0$$

$$x - (x - 1) + x^2 - x - 6x + 6 = 0$$

$$x^3 (x - 1) + x(x - 1) - 6(x - 1) = 0$$

$$(x - 1)(x^2 + x - 6) = 0$$

$$(x - 1)(x^2 + 3x - 2x - 6) = 0$$

$$(x - 1)[x(x + 3) - 2(x + 3)] = 0$$

$$(x - 1)(x + 3)(x - 2) = 0$$

If $x - 1 = 0$ If $x + 3 = 0$ If $x - 2 = 0$

$$x = 1 \quad x = -3 \quad x = 2$$

$$= 1, 2, -3$$

JUNE 2022

Question 1

The values of x and y satisfying the equations

$$\frac{3}{x+y} + \frac{2}{x-y} = 3, \frac{2}{x+y} + \frac{2}{x-y} = 3\frac{2}{3} \text{ are given by:}$$

(a) (1, 2)

(b) (-1, -2)

(c) (1, $\frac{1}{2}$)

(d) (2, 1)

Answer: Options (d)

Explanation:

Given $\frac{3}{x+y} + \frac{2}{x-y} = 3$ _____ (1)

$\frac{2}{x+y} + \frac{3}{x-y} = 3\frac{2}{3}$ _____ (2)

By Hits/ Trial

Putting $x = 2, y = 1$ in equation (1)

$$\frac{3}{2+1} + \frac{2}{2-1} = 3$$

$$1 + 2 = 3$$

$$3 = 3 \text{ (which is satisfied)}$$

and putting $x = 2, y = 1$ in equation (2)

$$\frac{2}{2+1} + \frac{3}{2-1} = 3\frac{2}{3}$$

$$\frac{2}{3} + \frac{3}{1} = \frac{11}{3}$$

$$\frac{11}{3} = \frac{11}{3} \text{ (which is satisfied)}$$

Question 2

If the second root of the given equation is reciprocal of first root then value of 'k' in the equation $5x^2 - 13x + k = 0$

- (a) 3 (b) 2
(c) 1 (d) 5

Answer: Options (d)

Explanation:

Given Q.E. $5x^2 - 13x + k = 0$
 on comparing $ax^2 + bx + c = 0$
 We get, $a = 5, b = -13, c = k$
 if one root is reciprocal to other
 Roots then $c = a$
 $k = 5$

Question 3

A Plumber can be paid, either ₹ 600 and ₹ 50 per hour or ₹ 170 per hour. If the job takes 'n' hour, for what value of 'n' the method earns better wages for the plumber?

- (a) 5 (b) 6
(c) 4 (d) 7

Answer: Options (a)

Explanation:

Let Plumber takes 'n' hour to complete the jobs

Given, $600 + 50 \times n = 170 \times n$

$$600 + 50n = 170n$$

$$600 = 170 - 50n$$

$$600 = 120n$$

$$n = \frac{6000}{120}$$

$$n = 5$$

Question 4

If a person has cloth of total 91 cm. If he divides it into 3 parts then longest part is twice the shortest one and another part is 3 cm more than shortest one. What is the shortest one?

- (a) 25 (b) 44
(c) 22 (d) 46

Answer: Options (c)

Explanation:

Let shortest part = x

longest part = 2x

other part = (x + 3)

Given total length of cloths = 91

$$x + 2x + (x + 3) = 91$$

$$x + 2x + x + 3 = 91$$

$$4x + 91 - 3$$

$$4x = 88$$

$$x = \frac{88}{4}$$

$$x = 22$$

DEC 2022**Question 1**

What will be the value of k, if the roots of the equation $(k-4)x^2 - 2kx + (k+5) = 0$ are equal?

- a) 18 b) 20
c) 19 d) 21

Answer: Options (b)

Explanation:

$$(k-4)x^2 - 2kx + (-k+5)$$

$$b^2 - 4ac$$

$$(-2k)^2 - 4(k-4)(k+5) = 0$$

Now with option b

$$(-2 \times 20)^2 - 4(20-4)(20+5) = 0$$

$$1600 - 4(16)(25) = 0$$

$$1600 - 1600 = 0$$

$$= 20$$

Question 2

If $2x + 5 > 3x + 2$ and $2x - 3 < 4x - 5$ the 'x' can take which of the following value?

- a) 4 b) -4
c) 2 d) -2

Answer: Options (b)

Explanation:

$$2x + 5 > 2 + 3x$$

$$5 - 2 > 3x - 2x$$

$$3 > x \quad (1)$$

$$2x - 3 < 4x - 5$$

$$5 - 3 < 4x - 2x \quad (2)$$

From (1) and (2)

$$x = 1 \text{ or } 2$$

Question 3

If the cost of 3 bags and 4 pens is Rs. 257 whereas the cost of 4 bags and 3 pens is Rs. 324, then the cost of one bag is:

- a) 8 b) 24
c) 32 d) 75

Answer: Options (d)

Explanation:

Let the cost of 1 bag = x

And the cost of 1 pen = y

$$\Rightarrow 3x + 4y = 257$$

$$\Rightarrow 4x + 3y = 324$$

$$\text{Equation (1)} \times 4 : 12x + 16y = 257 \times 4$$

$$\text{Equation (2)} \times 3 : 12x + 9y = 324 \times 3$$

Subtract two equations:

$$\Rightarrow 7y = 56$$

$$\Rightarrow y = 8$$

$$\Rightarrow x = 75$$

CHAPTER - 3 LINEAR INEQUALITIES

INEQUALITIES

Inequalities are statements where two quantities are unequal but a relationship exists between them. These type of inequalities occur in business whenever there is a limit on supply, demand, sales etc.

LINEAR INEQUALITIES IN ONE VARIABLE AND THE SOLUTION SPACE

Any linear function that involves an inequality sign is a linear Inequality. It may be of one variable or, of more than one variable. simple example of linear inequalities are those of one variable only ; viz., $x > 0$, $x \leq 0$ etc.



SUMMARY OF GRAPHICAL METHOD

It involves:

- i. Formulating the linear programming problem, i.e. expressing the objective function and constraints in the standardized format.
- ii. Plotting the capacity constraints on the graph paper. For this purpose, normally two terminal points are required. This is done by presuming simultaneously that one of the constraints is zero. When constraints concern only one factor, then line will have only one origin point and it will run parallel to the other axis.
- iii. Identifying feasible region and coordinates of corner points. Mostly it is done by breaching the graph, but a point can be identified by solving simultaneous equation relating to two lines which intersect to form a point on graph.
- iv. Testing the corner point which gives maximum profit. For this purpose, the coordinates relating to the corner point should put in objectives function and the optimal point should be ascertained.
- v. For decision – making purpose, sometimes, it is required to know whether optimal point leaves some resources unutilized. For this purpose, value of coordinates at the optimal point should be put with constraint to find out which constraints are not fully utilized.
- vi. Linear inequalities in two variables may be solved easily by extending our knowledge of straight lines.



Question 1

On solving the inequalities $6x + y \geq 18$, $x + 4y \geq 12$, $2x + y \leq 10$, we get the following situation:

- | | |
|--|---|
| (a) (0, 18), (12, 0), (4, 2), & (7, 6) | (b) (3, 0), (0, 3), (0, 0) and (7, 6) |
| (c) (5, 0), (0, 10), (4, 2), (7, 6) | (d) (0, 18), (12, 0), (4, 2), (0, 0) and (7, 6) |

Answer: a

Explanation:

We draw the graph of $6x+y \geq 18$, $x+4y \geq 12$, and $2x+y \leq 10$ in –the same plane. The solution set of system is that portion of the graphs of the given inequality which is represented by the intersection of the above three equations.

Question 2

Solve $x + 2 < 4$

- | | |
|----------------|-------------|
| (a) $x < 2$ | (b) $x > 2$ |
| (c) $x \neq 2$ | (d) $x < 4$ |

Answer: a

Explanation:

We need to subtract 2 from both sides of the inequality.

$$x + 2 < 4$$

$$x < 4 - 2$$

$$x < 2$$

Question 3

Solve the inequality $3 - 2x \geq 15$

- | | |
|----------------|-----------------|
| (a) $x \leq 6$ | (b) $x \leq -6$ |
| (c) $x > -6$ | (d) $x > 6$ |

Answer: b

Explanation:

We need to subtract 3 from both sides; then divide both sides by -2 (remembering to change the direction of the inequality).

$$= 3 - 2x \geq 15$$

$$= -2x \geq 15 - 3$$

$$= -2x \geq 12$$

$$= x \leq \frac{12}{-2}$$

$$= x \leq -6$$

Question 4

Solve $-1 < 2x + 3 < 6$

- | | |
|--------------------|---------------------|
| (a) $-2 < x < 3/2$ | (b) $2 < x < 23/2$ |
| (c) $2 < x < 3/2$ | (d) $-3 < x < 23/3$ |

Answer: a

Expectation:

$$= -1 < 2x + 3 < 6$$

Subtract 3 from all 3 sides

$$= -1-3 < 2x+3-3 < 6-3$$

$$= -4 < 2x < 3$$

Divide all sides by 2

$$= -2 < x < 3/2$$

Question 5

Solve $\frac{x}{2} > 8$

- (a) $x < 8$
- (b) $x > 16$
- (c) $x = 8$
- (d) $x = 4$

Answer: b

Explanation:

$$= \frac{x}{2} > 8$$

$$= x > 8 \times 2$$

$$= x > 16$$

Question 6

The graph to express the inequality $x + y = 56$ is:

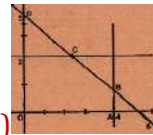
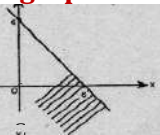

- (a)
- (b)
- (c) Either a or b
- (d) None of these

Answer: a

Explanation:

$x + y = 56$ is graphically represent by

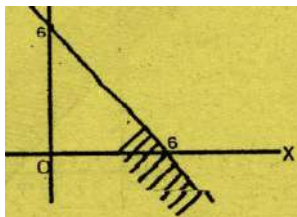

Question 7

On the average, experienced person does 5 units of work while fresh one 3 units work daily but the employer have to maintain the output to at least 30 units work per day. The situation can be expressed as

- (a) $5x - 3y = 30$
- (b) $5x + 3y = 30$
- (c) $- 5x + 3y = 30$
- (d) None of these

Answer: b

Explanation:

Let Experience Person x unit work per day
 Fresh one = y unit work per day
 So situation is $5x + 3y = 30$

Question 8

Common region of the inequalities is:

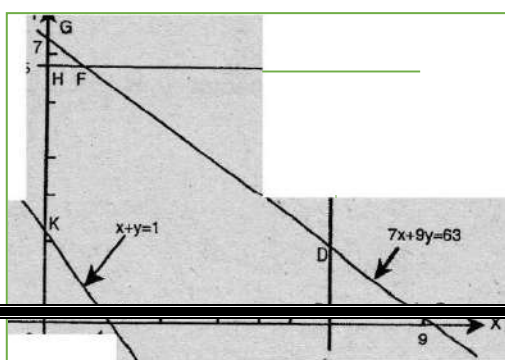

Info Visit - www.KITest.in

- (a) BCDB and DEFD
- (b) Unbounded
- (c) HFGH
- (d) ABDFHKA

Answer: d

Explanation:

Common region of the inequalities is ABDFHKA

Question 9

The shaded region represents:

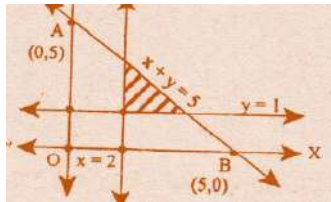

- (a) $x + y \leq 5, x \geq 2, y \leq 1$
- (b) $x + y \leq 5, x \geq 2, y \geq 1$
- (c) $x + y \leq 5, x \geq 2, y \leq 1$
- (d) None of these

Answer: b

Explanation:

Region represented by the line $x + y = 5$ touch the coordinate axes at $(5, 0)$ and $(0, 5)$ since the shaded region lies below the line $x + y = 5$. Hence it is represented by the in equation $x + y \leq 5$

Question 10

A company produces two products A and B, each of which requires processing in two machines. The first machine can be used at most for 60 hours, the second machine can be used at most for 40 hours. The product A requires 2 hours on machine one and one hour on machine one and two hours on machine two. Above situation is using linear inequalities?

- (a) True
- (b) False
- (c) Partial
- (d) None

Answer: a

Explanation:

Let the company produce, x number of product A and y number of product B.

As each of product A requires 2 hours in machine one and one hour in machine two, x number of product A requires $2x$ hours in machine one and x hours in machine two. Similarly, y number of product B requires y hours in machine one and $2y$ hours in machine two for 40 hours. Hence $2x + y$ cannot exceed 40. In other words,

$$2x + y = 60 \text{ and } x + 2y = 40$$

Thus, the conditions can be expressed using linear inequalities.

Question 11

The inequalities $5x_1 + 4x_2 \geq 9, x_1 + x_2 \geq 3, x_1 \geq 0$ and $x_2 \geq 0$ is correct?

- (a) True
- (b) False
- (c) Not sure
- (d) None

Answer: a

Explanation:

We draw that straight lines $5x_1 + 4x_2 = 9$ and $x_1 + x_2 = 3$.

Table for $5x_1 + 4x_2 = 9$

x_1	0	$9/5$
x_2	$9/4$	0

Table for $x_1 + x_2 = 3$

x_1	0	3
x_2	3	0

Now, if we take the point $(4, 4)$, we find $5 \times 1 + 4 \times 2 = 9$

For more Info Visit - www.KITest.in

i.e., $5.4 + 4.4 * 9$

or, $36 * 9$ (True)

$x_1 + x_2 * 3$

i.e., $4 + 4 * 3$

$8 * 3$ (True)

Hence (4, 4) is in the region which satisfies the inequalities

Question 12

Solve the inequality $-2(x+3)<10$

(a) $x>-8$

(b) $x>16$

(c) $x>8$

(d) $x>-16$

Answer: a

Explanation:

$$-2x-6<10-2x-6<10$$

$$-2x-6+6<10+6-2x-6+6<10+6$$

$$-2x<16-2x<16$$

$$-2x-2<16-2-2x-2>16-2$$

$$x>-8$$

Question 13

Solve the absolute value inequality $2|3x + 9|<36$

(a) $-9<x>3$

(b) $-9<x<3$

(c) $9<x>3$

(d) $9<x<3$

Answer: b

Explanation:

$$2|3x + 9|<36 \quad 2|3x + 9|2<36$$

$$|3x + 9|<18|$$

$$-18<3x+9$$

$$-18-9<3x$$

$$-27<3x$$

$$-9 <x$$

Question 14

Solve $x + 2 < 4$

(a) $x < 1$

(b) $x > 2$

(c) $x > -2$

(d) $x < 2$

Answer: d

Explanation:

We need to subtract 2 from both sides of the inequality.

$$x+2<4$$

$$x<4-2$$

$$x<2$$

Question 15

Solve $\frac{x}{2}>4$

(a) $x<4$

(b) $x>8$

(c) $x>-4$

(c) $x<2$

Answer: b

Explanation:

We need to multiply both sides of the inequality by 2.

$$\frac{x}{2}>4$$

$$x>4 \times 2$$

$$x>8$$

Question 16Solve the inequality $\frac{3}{2}(1-x) > \frac{1}{4} - x$

(a) $x < \frac{5}{2}$

(b) $x < 5$

(c) $x < \frac{10}{2}$

(d) $x < \frac{5}{6}$

Answer: a**Explanation:**

$$\frac{3}{2}(1-x) > \frac{1}{4} - x$$

$$6-6x > 1-4x$$

$$-6x+4x > 1-6$$

$$-2x > -5$$

$$x < \frac{5}{2}$$

Question 17The solution of the inequality $8x + 6 < 12x + 14$ is:

(a) (-2, 2)

(b) (0, -2)

(c) (2,)

(d) (-2,)

Answer: d**Explanation:**

$$= 8x + 6 < 12x + 14$$

$$= 6 - 14 < 12x - 8x$$

$$= -8 < 4x$$

$$= x > -2$$

Question 18Solve $x-1 < 2x+2 < 3x+1$

(a) $(x > 3 \text{ and } x > 1)$

(b) $(x > -3 \text{ and } x < 1)$

(c) $(x < -3 \text{ and } x > 1)$

(d) $(x > 1)$

Answer: d**Explanation:**

We need to find the intersecting of the "true" values.

$$x-1 < 2x+2 \text{ and } 2x+2 < 3x+1$$

$$x < 2x+3 \text{ and } 2x < 3x-1$$

$$x > -3 \text{ and } x > 1$$

The intersection of these 2 regions is $x > 1$.**Question 19**Solve $-2(x+4) > 1 - 5x$

(a) $x < 3$

(b) $x > 3$

(c) $x \neq 3$

(d) $x = 3$

Answer: b**Explanation:**

$$-2(x+4) > 1-5x$$

$$[-2x-8] > 1-5x$$

$$3x-8 > 1$$

$$3x > 9$$

$$x > 3$$

Question 20Solve the inequality $|2x - 1| > 5$

(a) $x < 3$

(b) $x > 3$

(c) $x \neq 3$

(d) $x = 3$

Answer: b**Explanation:**

Applying the relationships discussed earlier:

$$2x-1 < 5 \text{ or } 2x-1 > 5$$

Solving both inequalities, we get:

$$2x < 5+1 \quad \text{or} \quad 2x > 5+1$$

$$2x < -4 \quad \text{or} \quad 2x > 6$$

$$x < -2 \quad \text{or} \quad x > 3$$

Question 21**Find all pair if consecutive even positive integers, both of the which are larger than 5 such that their sum is less than 23.**

(a) (7,8),(7,3)and(2,3)

(b) (6,8),(8,10)and(10,12)

(c) (5,7),(7,9)and(2,6)

(d) (2,3),(4,5)and(3,1)

Answer: b**Explanation:**Let x and $x+2$ be two consecutive even positive integers.Since both the integers are larger than 5. $x > 5, x+2 > 5$ ----- (1)

Also sum of two is less than 23

$$x+x+2 < 23$$

$$\Rightarrow 2x+x < 23$$

Adding -2 to both sides

$$2x < 23-2$$

$$2x < 21$$

Dividing by 2 on both sides

$$\frac{2x}{2} < 23 - 2$$

$$x < \frac{21}{2}$$

$$x < 10.5$$

Step 2:

Since x is an even positive integer greater than 5 and less than 10.5 x can take value 6,8,10.

Thus the required pair of number is (6, 8), (8, 10) and (10, 12)

Hence B is the correct answer.

Question 22**The longest side of a triangle is three times the shortest side and third side is 2cm shorter than the longest side. If the perimeter of the triangle is at least 61cm. find the minimum length of the shortest side.**

(a) 9cm

(b) 3cm

(c) 5cm

(d) None of these

Answer: a**Explanation:**Let the length of the shortest side be x cmLength of the largest side is $3x$ cmLength of the third side is $3x-2$ cm

Since the perimeter of the triangle is at least 61 cm, we get,

$$x+3x+3x-2 \geq 61$$

$$7x-2 \geq 61$$

Adding 2 on both sides

$$\Rightarrow 7x \geq 61 + 2$$

$$7x \geq 63$$

Dividing both sides by positive number 7

$$\frac{7x}{7} \geq \frac{63}{7}$$

$$x \geq 9$$

Step 2:

The minimum length of the shortest side is 9 cm.

Hence A is the correct answer.

Question 23

Solve the inequality: $2 \leq 3x - 4 \leq 5$

(a) [2, 8]

(b) [4, 5]

(c) [3, 4]

(d) [2, 3]

Answer: d

Explanation:

The given inequality is $2 \leq 3x - 4 \leq 5$

Adding +4+4 throughout the inequality $2+4 \leq 3x - 4 + 4 \leq 5 + 4$

$$= > 6 \leq 3x \leq 9$$

Dividing by positive number 3 throughout the inequality $= > 2 \leq x \leq 3$

$$= > 2 \leq x \leq 3$$

Step 2:

Thus all real number, which are greater than or equal to 2, and less than or equal to 3, are solutions to the given inequality.

The solution set is [2, 3]

Hence D is the correct answer.

Question 24

Graphs of in equations are drawn below:

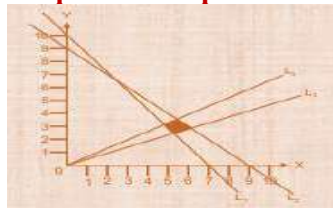

L1: $5x+3y=30$

L2: $x+ y = 9$

L3: $Y=X/3$

L4: $y=x/2$

The common region (Shaded part) shown in the diagram refers to the inequalities

(a) $5x+3y \leq 30$

(b) $5x + 3y \geq 30$

$X + y \leq 9$

$x + y \leq 9$

$Y \leq 1/2x$

$y \geq x/3$

$y \leq x/2$

$y \leq x/2$

$x \geq 0, y \geq 0$

$x \geq 0, y \geq 0$

(c) $5x+3y \geq 9$

(d) None of these

$X + y \geq 9$

$Y \leq x/3$

$y \geq x/2$

$x \geq 0, y \geq 0$

Answer: d

Explanation:

$$5x + 3y > 30$$

$$X + y < 9$$

$$Y > 9$$

$$Y \leq x/2$$

$$X \geq 0; y \geq 0$$

PAST EXAMINATION QUESTIONS:

MAY 2018

Question 1

The linear relationship between are variable in an inequality:

- (a) $ax+by \leq c$ (b) $ax.by \leq c$
 (c) $axy+by \leq c$ (d) $ax+bxy \leq c$

Answer: a

The linear relationship between two variables in an inequality $ax+by \leq c$

NOV 2018

Question 1

On solving the inequalities $5x+y \leq 100$, $x+y \leq 60$, $x \geq 0$, $y \geq 0$, we get the following solutions:

- (a) (0,0), (20, 0), (10, 50), & (0, 60) (b) (0,0), (60,0), (10,50) & (0,60)
 (c) (0,0), (20,0), (0,100), & (10,50) (d) None

Answer: a

Explanation:

On solving the inequalities $5x+y \leq 100$, $x+y \leq 60$, $x \geq 0$, $y \geq 0$, we get (0, 0), (20, 0) (10, 50) & (0, 60) all satisfied above inequalities

MAY 2019

Question 1

The solution set of the in equation $x + 2 > 0$ and $2x - 6 > 0$ is

- (a) $(-2, \infty)$ (b) $(3, \infty)$
 (c) $(-\infty, -2)$ (d) $(-\infty, -3)$

Answer: b

Explanation:

$$X + 2 > 0$$

$$X > -2$$

$$X > \frac{6}{2}$$

$$X > 3$$

$$X \in (3, \infty)$$

$$2X - 6 > 0$$

$$2X > 6$$

Questions 2

The common region represented by the following in equalities

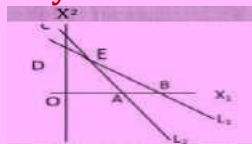

$$L_1 = X_1 + X_2 \leq 4; L_2 = 2X_1 + X_2 \geq 6$$

- (a) OABC (b) Outside of OAB
 (c) $\triangle BCE$ (d) $\triangle ABE$

Answer: d

Explanation:

$$= x_1 + x_2 \leq 4 - L_1$$

$$= 2x_1 + x_2 \geq 6 - L_2$$

$\triangle ABE$

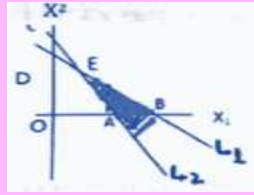

NOV 2019

Question 1

$6x + y \geq 18$, $x + 4y \geq 12$, $2x + y \geq 10$ on solving the inequalities; we get

(a) (0, 18), (12, 0), (4, 2), & (7, 6)

(b) (3, 0), (0, 3), (4, 2), & (7, 6)

(c) (5, 0), (0, 10), (4, 2), & (7, 6)

(d) (0, 18), (12, 0), (4, 2), & (0, 0), and (7, 6)

Answer: (a)

We draw the graph of $6x + y \geq 18$, $x + 4y \geq 12$ and $2x + y \geq 10$ in the same plane.

The solution set of system is that portion of the graphs of the given inequality which is represented by the intersection of the above three equations.

For this purpose, we replace, the inequalities respectively by

$$6x + y = 18, x + 4y = 12 \text{ and } 2x + y = 10$$

$$\text{For } 6x + y = 18, \text{ For } x + y = 12$$

x	0	3
y	18	0

X	0	12
y	3	0

For $2x + y = 10$

x	0	5
y	10	0

DEC 2020

Question 1

If $Y = x(x-1)(x-2)$ then dy/dx is

(a) $-6x$

(b) $3x^2 - 6x + 2$

(c) $6x + 4$

(d) $3x^2 - 6x$

Answer: b

Explanation:

$$y = x(x-1)(x-2)$$

$$y = (x^3 - 2x^2 - x^2 + 2x)$$

$$\frac{dy}{dx} = \frac{d}{dx} (x^3 - 2x^2 - x^2 + 2x)$$

$$\frac{dy}{dx} = 3x^2 - 4x - 2x + 2$$

$$\frac{dy}{dx} = 3x^2 - 6x + 2$$

Question 2

The average cost function of a good is $2Q + 6 + Q/13$ where Q is the quantity produced. The approx. cost at $Q = 15$ is__

(a) 42

(b) 36

(c) 66

(d) None of these

Answer: d**Explanation**

Note: According to the given question the correct answers is Rs.553. There is no correct

JAN 2021

Question 1

The common region in the graph of the inequalities $x + y \leq 4$, $x - y \leq 4$, $x \geq 2$, is.

(a) equilateral triangle

(b) Isosceles triangle

(c) Quadrilateral

(d) Square

Answer: b**Explanation:**common region in the graph of the inequalities $x + y \leq 4$, $x - y \leq 4$, $x \geq 2$, is it made isosceles triangle

Question 2

If $A + B = \begin{bmatrix} 1 & 0 \\ 1 & 1 \end{bmatrix}$ and $A - 2B = \begin{bmatrix} -1 & 1 \\ 0 & -1 \end{bmatrix}$, then $A =$ (a) $\begin{bmatrix} 1 & 1 \\ 2 & 1 \end{bmatrix}$ (b) $\begin{bmatrix} 2/3 & 1/3 \\ 1/3 & 2/3 \end{bmatrix}$ (c) $\begin{bmatrix} 1/3 & 1/3 \\ 2/3 & 1/3 \end{bmatrix}$ (d) $\begin{bmatrix} 2 & 1 \\ 1 & 2 \end{bmatrix}$ **Answer: c****Explanation:**

$$2(a+b) = 2 \begin{bmatrix} 1 & 0 \\ 1 & 1 \end{bmatrix} = 2A + 2B = \begin{bmatrix} 2 & 0 \\ 2 & 2 \end{bmatrix} \text{----- (1)}$$

$$A - 2B = \begin{bmatrix} -1 & 1 \\ 0 & -1 \end{bmatrix} \text{----- (2)}$$

$$2A + 2B + A - 2B = \begin{bmatrix} 2 & 0 \\ 2 & 2 \end{bmatrix} + \begin{bmatrix} -1 & 1 \\ 0 & -1 \end{bmatrix}$$

$$3A = \begin{bmatrix} 1 & 1 \\ 2 & 1 \end{bmatrix}$$

$$A = \frac{1}{3} \begin{bmatrix} 1 & 1 \\ 2 & 1 \end{bmatrix}$$

$$\text{Hence answer will be} = \begin{bmatrix} 1/3 & 1/3 \\ 2/3 & 1/3 \end{bmatrix}$$

Question 3

The matrix $A = \begin{bmatrix} 1 & -2 & 3 \\ 1 & -3 & 4 \\ -1 & 1 & -2 \end{bmatrix}$ is

(a) Symmetric

(b) Skew - symmetric

(c) Singular

(d) Non - Singular

Answer: c**Explanation:**A singular matrix is one which is non-invertible i.e. there is no multiplicative inverse, B, such that the original matrix $A \times B = I$ (Identity matrix) A matrix is singular if and only if its determinant is zero.

Question 4

For more Info Visit - www.KITest.in

The cost function of production is given by $C(x) = \frac{x^3}{2} - 15x^2 + 36x$ where x denotes the number of items produced. The level of output for which marginal cost is minimum and the level of output for which the average cost is minimum are given by, respectively

- (a) 10 and 15
(b) 10 and 12
(c) 12 and 15
(d) 15 and 10

Answer: a

Question 5

$$\int_1^0 e^x \left(\frac{1}{x} - \frac{1}{x^2} \right) dx =$$

- (a) $e\left(\frac{e}{2} - 2\right)$
(b) $e(e - 1)$
(c) a
(d) $e^2(e - 1)$

Answer: a

JULY 2021

Question 1

If $y = 4 + 9 \sin 5x$ then which holds good?

- (a) $-5 \leq y \leq 13$
(b) $-4 \leq y \leq 8$
(c) $0 < y < 1$
(d) $-5 < y < 5$

Answer: Options (a)

DEC 2021

Question 1

XYZ Company has a policy for its recruitment as: it should not recruit more than eight men (x) to three women (y). How can this fact be expressed in inequality?

- (a) $3y \geq 8x$
(b) $3y \leq x/8$
(c) $8y \geq 3x$
(d) $8y \leq 3x$

Answer: c

Explanation:

As per the company's policy,

When $y=3$, $x \leq 8$

It can also be written as:

When $\frac{y}{3} = 1$ -----Eq (1)

$\frac{x}{8} \leq 1$ Eq (2)

Now, as per Eq 1, we have $\frac{y}{3} = 1$

It can also be written as $1 = \frac{y}{3}$... Eq 3

Substituting the value of $1 = \frac{y}{3}$ from eq (3) to Eq(2), we'll get:

$$\frac{x}{8} \leq \frac{y}{3}$$

$$3x \leq 8y$$

$$8y \geq 3x$$

DEC 2022

Question 1

For more Info Visit - www.KITest.in

The solution of the following system of linear equations $2x-5y+4=0$ and $2x+y-8 = 0$ will be

a) (2, -3)

b) (1, -3)

c) (3, 2)

d) (-2, 2)

Answer: c

Explanation:

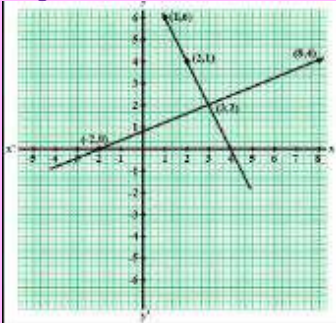

$$2x-5y+4=0\dots(1)$$

$$2x+y-8=0\dots(2)$$

Isolate x from equation (1) and find the value of x and y.

$$2x-5y+4=0$$

$$\text{or } 2x=5y-4$$

$$x=(5y-4)/2$$

x:	-2	3	8
y:	0	2	4

Similarly, isolate x from equation (2) and find the values of x and y.

$$2x+y-8=0$$

$$\text{or } y=8-2x$$

x:	1	2	3
y:	6	4	2

Graph:

Both the lines intersect each other at point (3,2).

So, $x=3, y=2$

CHAPTER - 4 TIME VALUE OF MONEY

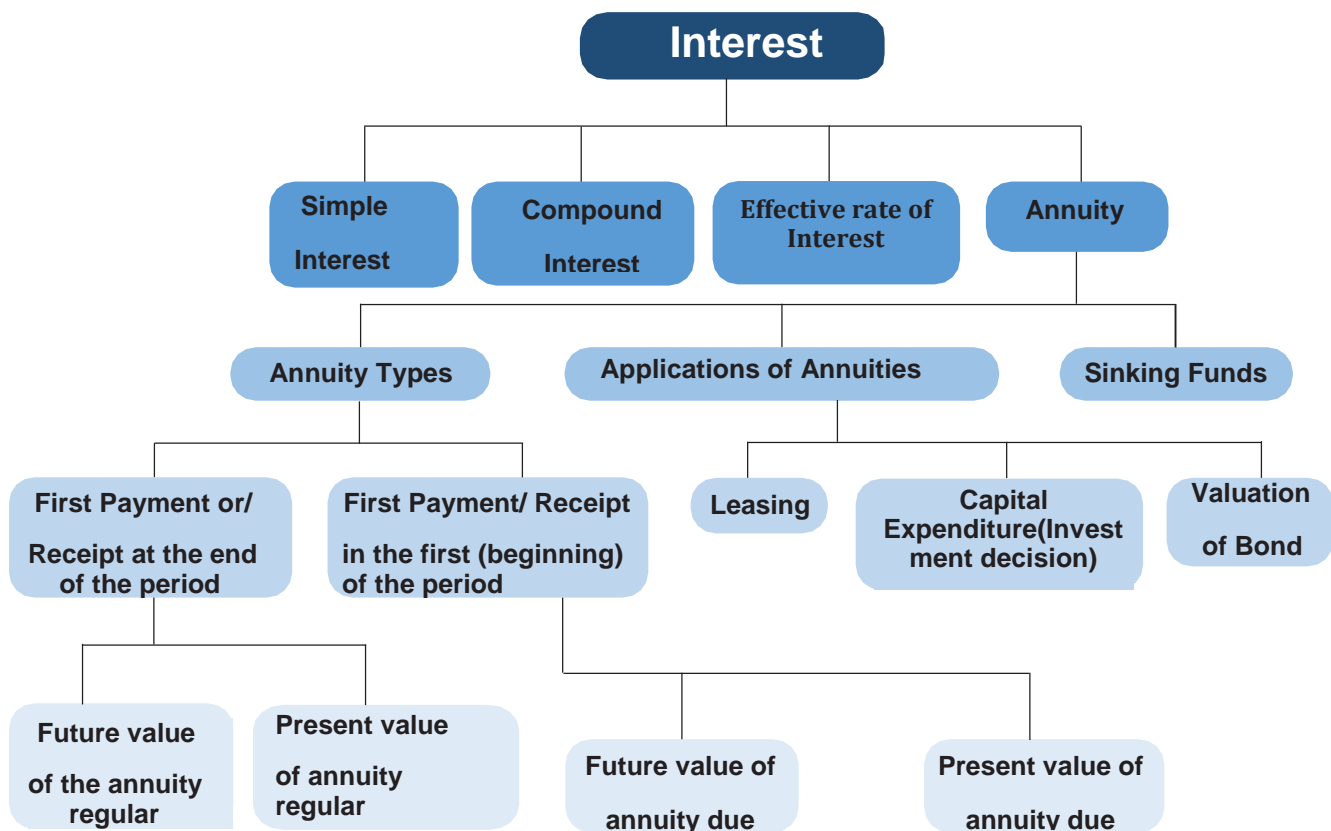

TIME VALUE OF MONEY	Time value of money means that the value of a unity of money is different in different time periods. The sum of money received in future is less valuable than it is today. In other words, the present worth of money received after some time will be less than a money received today.
INTERSEST	Interest is the price paid by a borrower for the use of a lender’s money. If you borrow (or lend) some money from (or to) a person for a particular period, you would pay (or receive) more money than your initial borrowing (or lending).
SIMPLE INTEREST	The interest computed on the principal for the entire period of borrowing. $I = Pit$ $A = P + I$ $I = A - P$ Here, A = Accumulated amount (final value of an investment) P = Principal (initial Value of an investment)

	<p>i = Annual interest rate in decimal. I = Amount of interest t = Time in years</p>
COMPOUND INTEREST	<p>The interest that accrues when earnings for each specified period of time added to the principal thus increasing the principal base on which subsequent interest is computed.</p> <p>Formula for compound interest: $A_n = P (1+i)^n$ Where, i = Annual rate of interest n = Number of conversion periods per year Interest = $A_n - P = P (1+i)^n - P$ n is total conversions i.e. $t \times$ no. of conversions per year</p>
EFFECTIVE RATE OF INTEREST	<p>The effective interest rate can be computed directly by following formula: $E = (1+i)^n - P$ Where E is the effective interest rate i = actual interest rate in decimal n = number of conversation period</p>
FUTURE VALUE	<p>Future value of a single cash flow can be computed by above formula. Replace A by future value (F) and P by single cash flow (C.F.) therefore $F = C.F. (1+i)^n$</p>
ANNUITY	<p>Annuity can be defined as a sequence of periodic payments (or receipts) regularly over a specified period of time.</p>

TYPES OF ANNUITY

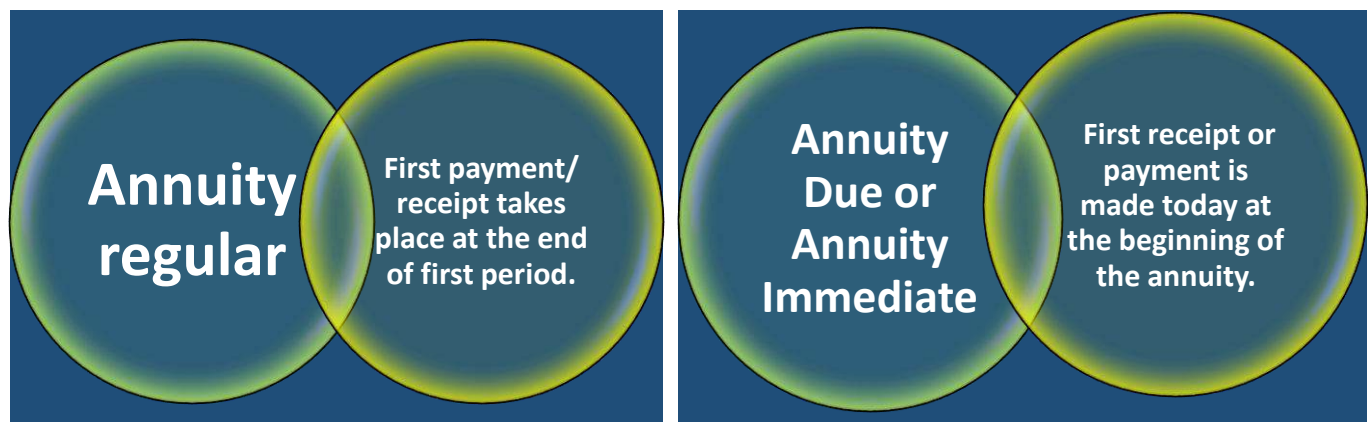

FUTURE VALUE	<p>Future value of an Annuity due/Annuity immediate = Future value of annuity regular $\times (1+i)$ where i is the interest rate is decimal.</p>
---------------------	---

<p style="text-align: center;">OF AN ANNUITY DUE/ANNUITY IMMEDIATE</p>	<p>The present value P of the amount an due at the end of n period at the rate of i per interest period may be obtained by solving for P the below given equation</p> $A_n = P(1 + i)^n$						
<p style="text-align: center;">PRESENT VALUE OF ANNUITY DUE OR ANNUITY IMMEDIATE</p>	<p>Present value of annuity due/immediate for n years is the same as an annuity regular for (n-1) years plus an initial receipt or payment in beginning of the period. Calculating the present value of annuity due involves two steps.</p> <ul style="list-style-type: none"> • Step 1: Compute the present value of annuity as if it were an annuity regular for one period short. • Step 2: Add initial cash payment/ receipt to the step 1 value. 						
<p style="text-align: center;">SINKING FUND</p>	<p>It is the fund credited for a specified purpose by way of sequence of periodic payments over a time period at a specified interest rate. Interest is compounded at the end of every period. Size of the sinking fund deposit is computed from $A = P.A(n, i)$ Where A is the amount to be saved the periodic payment, in the payment period.</p>						
<p style="text-align: center;">ANNUITY APPLICATIONS</p>	<table border="1" style="width: 100%;"> <tr> <td data-bbox="451 1111 667 1350">Leasing</td> <td data-bbox="667 1111 1463 1350">Leasing is a financial arrangement under which the owner of the asset (lessor) allows the user of the asset (lessee) to use the asset for a defined period of time (lease period) for a consideration (lease rental) payable over a given period of time. This is a kind of taking an asset on rent</td> </tr> <tr> <td data-bbox="451 1350 667 1518">Capital Expenditure</td> <td data-bbox="667 1350 1463 1518">Capital expenditure means purchasing on asset (which results in outflows of money) today in anticipation of benefits (cash inflow) which would flow across the life of the investment</td> </tr> <tr> <td data-bbox="451 1518 667 1686">Valuation of bond</td> <td data-bbox="667 1518 1463 1686">A bond is a debt security in which the issuer owes the holder a debt and is obliged to repay the principal and interest. Bonds are generally issued for a fixed term longer than one year.</td> </tr> </table>	Leasing	Leasing is a financial arrangement under which the owner of the asset (lessor) allows the user of the asset (lessee) to use the asset for a defined period of time (lease period) for a consideration (lease rental) payable over a given period of time. This is a kind of taking an asset on rent	Capital Expenditure	Capital expenditure means purchasing on asset (which results in outflows of money) today in anticipation of benefits (cash inflow) which would flow across the life of the investment	Valuation of bond	A bond is a debt security in which the issuer owes the holder a debt and is obliged to repay the principal and interest. Bonds are generally issued for a fixed term longer than one year.
Leasing	Leasing is a financial arrangement under which the owner of the asset (lessor) allows the user of the asset (lessee) to use the asset for a defined period of time (lease period) for a consideration (lease rental) payable over a given period of time. This is a kind of taking an asset on rent						
Capital Expenditure	Capital expenditure means purchasing on asset (which results in outflows of money) today in anticipation of benefits (cash inflow) which would flow across the life of the investment						
Valuation of bond	A bond is a debt security in which the issuer owes the holder a debt and is obliged to repay the principal and interest. Bonds are generally issued for a fixed term longer than one year.						

**Question 1**

How much interest will be earned on ₹2000 at 6 % simple interest for 2 years?

- (a) 250 (b) 240
(c) 260 (d) 270

Answer: b

Explanation:

Required interest amount is given by

$$\begin{aligned} I &= P \times i \times t \\ &= 2000 \times \frac{6}{100} \times 2 \\ &= 240 \end{aligned}$$

Question 2

Sonata deposited ₹50,000 in a bank for two years with the interest rate of 5.5% p.a. how much interest would she earn?

- (a) 550 (b) 55000
(c) 55 (d) 5500

Answer: d

Explanation:

Required interest amount is given by

$$\begin{aligned} I &= P \times i \times t \\ 50000 \times \frac{5.5}{100} \times 2 \\ &= 5500 \end{aligned}$$

Question 3

Sachin deposited ₹1,00,000 in his bank for 2 years at simple interest rate of 6%.

How much interest would he earn? How much would be the final value of deposit?

- (a) 11200 (b) 1,12,000
(c) 124000 (d) 12400

Answer: b

Explanation:

i. required interest amount is given by

$$\begin{aligned} I &= P \times i \times t \\ 100000 \times \frac{6}{100} \times 2 \\ &= 12,000 \end{aligned}$$

ii. Final value of deposit is given by

$$\begin{aligned} A &= P + I \\ &= (1,00,000 + 12,000) \\ &= 1,12,000 \end{aligned}$$

Question 4

Rohika invested 70,000 in a bank at the rate of 6.5% p.a. simple interest rate. He received 85,925 after the end of term. Find out the period for which sum was invested by Rahul.

- (a) 3.5 years (b) 35 years
(c) 0.35 years (d) 36 years

Answer: a

Explanation:

We know $A = P(1 + it)$

$$\text{i.e. } 85925 = 70000\left(1 + \frac{6.5}{100} \times t\right)$$

$$\frac{85925}{70000} = \frac{100 + 6.5t}{100}$$

$$\frac{85925 \times 100}{70000} - 100 = 6.5t$$

$$22.75 = 6.5t$$

$$t = 3.5$$

$$= \text{time} = 3.5 \text{ years}$$

Question 5

Kanti Devi deposited some amount in a bank for 7 ½ years at the rate of 6% p.a. simple interest. Kanti Devi received '1, 01,500 at the end of the term. Compute initial deposit of kanti Devi

- (a) 70000 (b) 7000
(c) 70 (d) 700000

Answer: a

Explanation:

We know, $A = P(1 + it)$

$$\text{i.e. } 101500 = P\left(1 + \frac{6}{100} \times \frac{15}{2}\right)$$

$$1, 01,500 = P\left[1 + \frac{45}{100}\right]$$

$$P = \frac{101500 \times 100}{145}$$

$$= 70,000$$

Initial deposit of kanti Devi = 70,000

Question 6

Shila has a sum of 46,875 was lent out at simple interest at the end of 1 year 8 months the total amount was 50,000. Find the rate of interest percent per annum.

- (a) 0.4% (b) 4 %
(c) 40% (d) 0.04%

Answer: b

Explanation:

We know $A = P(1 + it)$

$$\text{i.e. } 50,000 = 46875\left(1 + i \times 1 \frac{8}{12}\right)$$

$$i = 0.04;$$

$$\text{Rate} = 4\%$$

Question 7

What sum money will produce Heena 28,600 as an interest in 3 years and 3 months at 2.5% p.a. simple interest?

- (a) 35200 (b) 352000

(c) 32500

(d) 325000

Answer: b**Explanation:**We know $I = P \times i \times t$

$$\text{i.e. } 28,600 = P \times \frac{2.5}{100} \times 3\frac{3}{12}$$

$$28600 = \frac{2.5}{100}P \times \frac{13}{4}$$

$$28600 = \frac{32.5}{400}P$$

$$P = \frac{28600 \times 400}{32.5}$$

$$= 352000$$

3, 52,000 will produce 28,600 interests in 3 years and 3 months at 2.5%p.a. simple interest.

Question 8**In what time vash will do 85,000 amount to 1, 57,675 at 4.5% p.a.?**

(a) 9 years

(b) 91 years

(c) 19 years

(d) 1 year

Answer: c**Explanation:**

We know

$$A = P (1 + it)$$

$$157675 = 85000(1 + \frac{4.5}{100}t)$$

$$\frac{157675}{85000} = \frac{100 + 4.5t}{100}$$

$$4.5t = (\frac{157675}{85000} \times 100) - 100$$

$$t = \frac{85.5}{4.5} = t = 19$$

In 19 years 85,000 will amount to 1, 57,675 at 4.5% p.a. simple interest rate.

Question 9**A sum of money doubles itself in 10 years. The number of years it would triple itself is:**

(a) 25 years

(b) 20 years

(c) 15 years

(d) 18 years

Answer: b**Explanation:**

Let the sum of money invested be P.

Then, amount = 2P

$$A = P (1+it)$$

$$2p = p (1 + r \times \frac{10}{100})$$

$$2 = \frac{100+10r}{100}$$

$$10r=100$$

$$R=10\%p.a.$$

Now, year be 20 years

Question 10

A company establishes a sinking fund to provide for the payment of 2,00,000 debt maturing in 20 years. Contribution to the fund is to be made at the end of every year. Find the amount of each annual deposit if interest is 5% per annum.

- (a) 6142 (b) 6049
(c) 6052 (d) 6159

Answer: b

Explanation:

Let the annual deposit be A

$$F.Y. = 0 [(1+i)^n - 1]$$

$$2,00,000 = [(1+0.05)^{20} - 1]$$

$$10,000 = a (1.6533)$$

$$A = \frac{10000}{1.6533}$$

$$A = 6049$$

Question 11

A machine worth 4,90,740 is depreciated at 15% on its opening value each year. When its value would reduce to 2,00,000:

- (a) 5 years 6 months (b) 5 years 7 months
(c) 5 years 5 months (d) None

Answer: a

Explanation:

Amount = 2,00,000

In case of depreciation $A = P (1 - i)^t$

$$2,00,000 = 4,90,740 (1 - 0.15)^t$$

$$0.4075 = (0.85)^t$$

$$(0.85)^{5.5} = (0.85)^t$$

$$n = 5.5 \text{ or } 5 \text{ years } 6 \text{ months (approx.)}$$

Question 12

A sum amount to 1,331 at a principal of 1,000 at 10% compounded annually; Find the time.

- (a) 3.31 years (b) 4 years
(c) 3 years (d) 2 years

Answer: c

Explanation:

$$P = 1,000$$

$$A = 1,331$$

$$i = 0.10$$

Time = n years

$$A = P (1+i)^t$$

$$1331 = 1000 (1 + 0.10)^t$$

$$1.331 = (1.10)^t$$

$$(1.10)^3 = (1.10)^t$$

$$n = 3$$

Therefore, Rs. 1,000 amounts to 1,331 at 10% p.a. C.I. in 3 year's

Question 13

If a sum triples in 15 years at simple rate of interest, the rate of interest per annum will be

(a) 13.0%

(b) 13.33%

(c) 1.33%

(d) 13.66%

Answer: b**Explanation:**

Let Principal P = P

Amount A = 3P

T = 15 years

S.I. = A - P

= 3P - P

= 2P

$$R = \frac{\text{S.I.} \times 100}{P \times T}$$

$$R = \frac{2P \times 100}{P \times 15 \text{ Yrs.}}$$

$$R = \frac{40}{3}$$

$$= 13.33\%$$

Question 14**In what time will a sum of money double its y at 6.25 Simple interest?**

(a) 5 years

(b) 12 years

(c) 8 years

(d) 16 years

Answer: d**Explanation:**Let $R = \frac{6.25}{100}$. According to the question,

Amount = 2 (Principle)

A = 2P

S.I. = A - P

= 2P - P

= P

$$\text{S.I.} = \frac{P \times R \times T}{100}$$

$$P = \frac{P \times 6.25 \times T}{100 \times 100}$$

$$T = \frac{p \times 100 \times 100}{p \times 6.25}$$

T = 16 Years

Question 15**What principal will amount to 370 in 6 years at 8% p.a. at simple interest?**

(a) 210

(b) 250

(c) 260

(d) 25

Answer: b**Explanation:**

Given Amount (A) = 370, T = 6 yrs, R = 8% p.a.

Let P = x

$$\text{SI} = \frac{PRT}{100}$$

$$= \frac{8 \times 6 \times X}{100}$$

$$\text{S. I.} = \frac{48X}{100}$$

$$A = P + \text{S.I.}$$

$$A = X + \frac{48X}{100}$$

$$370 = \frac{148X}{100}$$

$$X = \frac{370 \times 100}{148}$$

$$= 250$$

Question 16

2,000 is invested at annual rate of interest of 10%. What is the amount after two years if compounding is quarterly?

- (a) 2420 (b) 2431
(c) 2436.80 (d) 2440.58

Answer: c

Explanation:

$$n = 4 \times 2 = 8$$

$$i = \frac{0.1}{4} = 0.025$$

$$A_8 = 2,000 (1+0.025)^8$$

$$= 2,000 \times 1.2184$$

$$= 2,436.80$$

Question 17

Determine the compound amount and compound interest on 1000 at 6% compounded semi-annually for 6 years. Given that $(1+i)^n = 1.42576$ for $i = 3\%$ and $n = 2$

- (a) 425.76 (b) 425.67
(c) 851.52 (d) 851.25

Answer: a

Solution:

Given:

Principal, P = Rs. 1,000

Rate of Interest = 6%

Time, = 6 years

And $(1 + i)^n = 1.42576$ for $i = 3\%$ and $n = 2$

We know compound amount, $A = P (1 + i)^n$

Since, the interest is compounded semi-annually for 6 years

Here, $i = \frac{6}{2}\% = 3\%$ and $n = 6 \times 2 = 12$

Compound Amount

$$A = P(1 + i)^n$$

$$= \text{Rs. } 1,000 (1 + 3\%)^{12}$$

$$= \text{Rs. } 1,000 \times 1.42576$$

$$= \text{Rs. } 1,425.76$$

Compound Interest = Rs. (1,425.76 - 1,000)

$$= \text{Rs. } 425.76$$

Question 18

2000 is invested at annual rate of interest of 10%. What is the amount after two years if compounding is done monthly?

- (a) 2420 (b) 2431
(c) 2436.80 (d) 244.058

Answer: d

Explanation:

$$A_n = P (1 + i)^n$$

$$n = 12 \times 2 = 24, i = 0.1/12 = 0.00833$$

$$A_{24} = 2,00 (1 + 0.00833)^{24}$$

$$= 2.00 \times 1.22029$$

$$= 2.44.058$$

Question 19

Which is a better investment 3% per year compounded monthly or 3.2% per year simple interest? Given that $(1+0.0025)^{12} = 1.0304$

- (a) 3.04% (b) 3.4%
(c) 3.004% (d) 4.03%

Answer: a

Explanation:

$$i = 3/12 = 0.25\% = 0.0025$$

$$n = 12$$

$$E = (1+i)^n - 1$$

$$= (1 + 0.0025)^{12} - 1$$

$$= 1.0304 - 1 = 0.0304$$

$$= 3.04\%$$

Effective rate of interest (E) being less than 3.2%. The simple interest 3.2% per year is the better investment.

Question 20

Bichara invest 3000 in a two-year investment that pays you 12% per annum. Calculate the future value of the investment.

- (a) 3,763.20 (b) 376.320
(c) 37632.00 (d) 37.6320

Answer: a

Explanation:

We know $F = C.F. (1 + i)^n$
Where F = Future value
C.F. = Cash flow = 3,000
i = rate of interest = 0.12
n = time period = 2

$$F = 3,000(1+0.12)^2$$

$$= 3,000 \times 1.2544$$

$$= 3,763.20$$

Question 21

As certain the compound value and compound interest of an amount of '75,000 at 8 percent compounded semiannually for 5 years.

- (a) 30615 (b) 36051
(c) 36501 (d) 36015

Answer: d**Explanation:**

Computation of compound value and compound interest

Semiannual rate of interest (i) = $8/2 = 4\%$ $n = 5 \times 2 = 10$, $P = 75,000$ Compound value = $P (1+i)^n$ $= 75,000(1+4\%)^{10}$ $= 75,000 \times 1.4802$ $= 1,11,015$ Compound interest = $1,11,015 - 75,000 = 36,015$.**Question 22**

A doctor is planning to buy an X – Ray machine for his hospital. He has two options. He can either purchase it by making cash payment of 5 lakhs or 6'15,000 are to be paid in six equal annual installments. Which option do you suggest to the doctor assuming the rate of return is 12 percent? Present value of annuity of Rs. 1 at 12 percent rate of discount for six years is 4.111

(a) 421378

(b) 412378

(c) 487321

(d) 421387

Answer: a**Explanation:**

Option I:

Cash down payment = 5,00,000

Option II:

Annual installment Basis

Annual installment = $615000 \times \frac{1}{6} = 102500$

Present value of 1 to 6 installments @ 12%

 $= 1,02,500 \times 4.111$ $= 4,21,378$ **Question 23**

Calculate if '10,000 is invested at interest rate of 12% per annum, what is the amount after 3 years if the compounding of interest is done half yearly?

(a) 14049.28

(b) 14185.19

(c) 14857.61

(d) 14094.28

Answer: b**Explanation:** $10,000 \left[1 + \frac{12}{100 \times 2} \right]^{3 \times 2}$ $10,000 (1 + 0.06)^6$ $= 10,000 \times 1.418519$ $= 14,185.19$ **Question 24**

Present value " is the current value of a " Future Amount ". The statement is correct or not?

(a) Correct

(b) incorrect

(c) Not sure

(d) None

Answer: a

Explanation:

Present value "is the current value of a "Future Amount". It can also be defined as the amount to be invested today (present value) at a given rate over specified period to equal the "Future Amount".

Question 25

Simple interest may be defined as interest that is calculated as a simple percentage of the restricted amount is true or false?

- (a) True (b) False
(c) Partial (d) None

Answer: b

Explanation:

Simple interest may be defined as interest that is calculated as a simple percentage of the original principal amount.

Question 26

Time value of money indicates that

- (a) A unit of money obtained today is worth more than a unit of money obtained in future (b) A unit of money obtained today is worth less than a unit of money obtained in future
(c) There is no difference in the value of money obtained today and tomorrow (d) None of these

Answer: a

Explanation:

A unit of money obtained today is worth more than a unit of money obtained in future.

Question 27

Time value of money supports the comparison of cash flows recorded at different time period by

- (a) Discounting all cash flows to a common point of time (b) Compounding all cash flows to a common point of time
(c) Using either a or b (d) None of the above

Answer: c

Explanation:

Time value of money supports the comparison of cash flows recorded at, different time period by discounting and compounding all cash flows to a common point of time.

Question 28

Accounting financial management → liquidity decisions

- (a) True (b) False
(c) Partial (d) None

Answer: b

Explanation:

False

It should be → the controller's responsibilities are primarily – in nature, while the treasure's responsibilities are primarily related to this.

Question 29

Richa borrowed a sum of Rs. 4800 from Ankita as a loan. She promised Ankita that she will pay it back in two equal installments. If the rate of interest be 5% per annum compounded annually, find the amount of each installment.

(a) 14049.28

(b) 2581.46

(c) 24857.61

(d) 14094.28

Answer: b

Explanation:

Given that principal value = 4800

Rate = 5%

Two equal installments annually = 2 years

Applying the formula, $P = X / (1+r/100)^n + \dots + X / (1+r/100)$

So, we have here two equal installments.

$P = X / (1+r/100)^2 + X / (1+r/100)$

$4800 = X / (1+5/100)^2 + X / (1+5/100)$

On simplifying

We have $x = \text{Rs. } 2581.46$

So, the amount of each installment is Rs. 2581.46

Question 30

A builder borrows Rs. 2550 to be paid back with compound interest at the rate of 4% per annum by the end of 2 years in two equal yearly installments. How much will each installment be?

(a) Rs. 1352

(b) Rs. 1377

(c) Rs. 1275

(d) Rs. 1283

Answer: a

Explanation:

Amount = Rs. 2550

Rate = 4% per annum

Time = 2 years

Applying the formula

$P = X / (1+r/100)^n + \dots + X / (1+r/100)$

Here we have two equal installments, so

$$P = \frac{1}{\left[1 + \frac{r}{100}\right]^2} + \frac{x}{\left[1 + \frac{4}{100}\right]}$$

= Rs. 1352

Question 31

A man buys a scooter on making a cash down payment of Rs. 16224 and promises to pay two more yearly installment of equivalent amount in next two years. If the rate of interest is 4% per annum, compounded yearly, the cash value of the scooter, is

(a) Rs. 40000

(b) Rs. 46824

(c) Rs. 46000

(d) Rs. 50000

Answer: b

Explanation:

Concept used in this question is: you need to calculate principal for every year unlike simple interest where principal used to be same for every year.

Let principal (present worth) for first year be P_1 and that for two years be P_2

$$16224 = P_1 \left[1 + \frac{4}{100} \right]$$

$$P_1 = \frac{16224 \times 25}{26} = \text{Rs. } 15600$$

$$\text{Again, } 16224 = P_2 \left[1 + \frac{4}{100} \right]^2$$

$$P_2 = \frac{16224 \times 625}{676} = \text{Rs. } 15000$$

The total payment will be (cash down payment + installment paid)

Cash value of the scooter

$$= \text{Rs. } (16224 + 15600 + 15000) = \text{Rs. } 46824.$$

Question 32

The populations of Chandigarh is increase at a rate of 1% for first year, it decrease at the rate of 4% for the second year and for third year it again increase at the rate of 5%. Then what will be the population of Chandigarh are 50000.

(a) Rs. 51006

(b) Rs. 50904

(c) Rs. 50836

(d) Rs. 51125

Answer: b

Explanation:

Since the rate growth of population is increasing first and then decreasing for the second year and again it increases for third year, then the population after T years will be

$$50,000 \times \left[1 + \frac{1}{100} \right]^1 \times \left[1 - \frac{4}{100} \right]^1 \times \left[1 + \frac{5}{100} \right]^1 = 50904$$

Question 33

A person bought a new machine. The value of the machine is Rs. 10000. If rate of depreciation is 5 % per annum, then what will be the value of the machine after 2 years?

(a) Rs. 9025

(b) Rs. 9044

(c) Rs. 9110

(d) Rs. 9080

Answer: a

Explanation:

Here P = Rs. 10000

Rate of depreciation = 5%

T = 2 years

Therefore, the value after 2 years will be = $P (1 - R/100)^t$

$$= 10,000 \left[1 - \frac{5}{100} \right]^2$$

$$= \text{Rs. } 9025.$$

Question 34

A sum of Rs. 6600 was taken as a loan. This is to be repaid in two equal annual installments. If the rate of interest be 20% compounded annually then the value of each installment is

(a) Rs. 4320

(b) Rs.4400

(c) Rs. 2220

(d) Rs. 4420

Answer: a

Explanation:

Present worth of Rs. X due T years hence is given by

$$\text{Present worth (PW)} = \frac{X}{\left(1 + \frac{R}{100} \right)^2} = 6600$$

$$\frac{X}{\left(\frac{6}{5}\right)} + \frac{X}{\left(\frac{6}{5}\right)^2} = 6600$$

$$\frac{5X}{6} + \frac{25X}{36} = 6600$$

$$\frac{55X}{36} = 6600.$$

$$X = \frac{6600 \times 36}{55} = 4320$$

Question 35

Simple interest on a sum at 5% per annum for 2 years is Rs. 60. The compound interest on the same sum for the same period is

- (a) Rs. 62.4 (b) Rs. 61.5
(c) Rs. 62 (d) Rs. 60.5

Answer: b

Explanation:

$$\text{Principal} = \frac{100 \times SI}{RT} = \text{Rs. } 600$$

$$\text{Compound interest} = P \left(1 + \frac{R}{100}\right)^T - P$$

$$= 600 \left(1 + \frac{5}{100}\right)^2 - 600$$

$$= 661.5 - 600 = \text{Rs. } 61.5$$

Question 36

What will be the amount if a sum of Rs. 10000 is placed at compound interest for 3 year while rate of interest for the first, second and third years is 2, 5 and 10 percent, respectively?

- (a) 11781 (b) 11244
(c) 11231 (d) 11658

Answer: a

Explanation:

When rates are different for different years, say $R_1\%$, $R_2\%$ and $R_3\%$ FOR 1ST, 2ND and 3rd year respectively.

$$A = P \left(1 + \frac{R_1}{100}\right) \left(1 + \frac{R_2}{100}\right) \left(1 + \frac{R_3}{100}\right)$$

$$\text{Amount after 3 years} = 10000 \left(1 + \frac{2}{100}\right) \left(1 + \frac{5}{100}\right) \left(1 + \frac{10}{100}\right)$$

$$= 10000 \left(\frac{102}{100}\right) \left(\frac{105}{100}\right) \left(\frac{110}{100}\right)$$

$$\frac{102 \times 105 \times 110}{10} = \text{Rs. } 11781$$

Question 37

An electronic type writer worth Rs. 12000 depreciates @ 10% P.A. ultimately it was sold for Rs. 200. Estimate its effective life during which it was in use?

- (a) 389 (b) 38.9
(c) 3.89 (d) None

Answer: b

Explanation:

$$200 = 12000 \times \left(\frac{90}{100}\right)^n$$

$$1/60 = \left(\frac{9}{10}\right)^n$$

Apply log both sides, we get

$$\text{Log } (1/60) = n \times \text{log } (9/10)$$

$$-1.7781 = n \times -0.0457$$

$$38.9 = n$$

Value of type writer becomes 200 after 38.9 years.

Question 38

An annuity with an extended life is classified as

- (a) extended life (b) perpetuity
(c) deferred perpetuity (d) due perpetuity

Answer: b

Explanation:

Perpetuity is a type of annuity that receives an infinite amount of periodic payments. An annuity is a financial instrument that pays consistent periodic payment. As with any annuity, the perpetuity value formula sums the present value of future cash flows.

Question 39

Periodic rate if it is multiplied with per year number of compounding periods is called

- (a) extrinsic rate of return (b) intrinsic rate of return
(c) annual rate of return (d) nominal annual rate

Answer: d

Explanation:

An interest rate is called **nominal** if the frequency of compounding (e.g. a month) is not identical to the basic time unit in which the **nominal rate** is quoted (normally a year).

Question 40

A deposit of Rs. 100 is placed into a college fund at the beginning of every month for 10 years. The fund earns 9% annual interest, compounded monthly, and paid at end of the month. How much is in the account right after the last deposit?

- (a) 193751.43 (b) 11244.43
(c) 11231.67 (d) 61658.67

Answer: a

Explanation:

The value of the initial deposit is Rs. 100, so $a_1 = 100$. A total of 120 monthly deposits are made in the 10 years, so $n = 120$. To find r , divide the annual interest rate by 12 to find the monthly interest rate and add 1 to represent the new monthly deposit.

$$r = 1 + \frac{0.09}{12} = 1.0075$$

Substitute $a_1 = 100$, $r = 1.0075$

, and $n = 120$ into the formula for the sum of the first n terms of a geometric series, and simplify to find the value of the annuity.

$$S_{120} = \frac{100(1-1.0075^{120})}{1-1.0075}$$

$$= 19351.73$$

Question 41

Relationship between annual nominal rate of interest and annual effective rate of interest, if frequency of compounding is greater than one:

- (a) Effective rate > Nominal rate (b) Effective rate < Nominal rate
(c) Effective rate = Nominal rate (d) None of the above

Answer: a

Explanation:

Effective rate > Nominal rate

PAST EXAMINATION QUESTIONS:

MAY 2018

Question 1

Mr. X invests Rs. 10,000 every year starting from today for next: 10 years suppose interest rate is 8% per annual compounded annually. Calculate future value of the annuity.

- (a) Rs.1,56,454.88
(b) Rs. 1,56,554.88
(c) Rs. 1,44,865.625
(d) None

Answer: a**Explanation:**

Annual Installment (A) = 10,000
R = 8% p.a.c.i

A=?
n = 10 years

Future value of Annuity due

$$A_{n,i} = \frac{A}{i} [(1+i)^n - 1] (1+i)$$

$$\frac{10,000}{0.08} [(1+0.08)^{10} - 1](1+0.08)$$

$$\frac{10,000}{0.08} [(1.08)^{10} - 1](1+0.08)$$

$$1, 56,454.88$$

Question2

How much amount is required to be invested every year so as to accumulate Rs. 3, 00, 000 at the end of 10 years, if interest is compounded annually at 10%?

- (a) Rs. 18,823.65
(b) Rs. 18,000
(c) Rs. 18,828.65
(d) Rs. 18,882.65

Answer: a**Explanation:**

Annuity (annual installment) = A

Future value $A_{n,i} = 3, 00,000$

R = 10%, n = 10 years

$$i = \frac{R}{100} = \frac{10}{100} = 0.1$$

$$A_{n,i} = \frac{A}{i} [(1+i)^n - 1]$$

$$3, 00,000 = \frac{A}{0.1} [(1+0.1)^{10} - 1]$$

$$= \frac{A}{0.1} [2.59374 - 1]$$

$$\frac{A}{0.1} \times 1.59374$$

$$3, 00,000 = A \times 15.9374$$

$$A = \frac{3,00,000}{15.9374} = \text{Rs. } 18,823.65$$

Question 3

If Rs. 1,000 be invested at interest rate of 5% and the interest is added to the principal every 10 years, then the number of years in which it will amount to Rs. 2,000 is

- (a) $16\frac{2}{3}$ years (b) $6\frac{1}{4}$ years
 (c) 16 years (d) $6\frac{2}{3}$ years

Answer: a

Explanation:

$P = 1,000$, $R = 5\%$ p.a.s.i., $T = 10$ years

$$SI = \frac{PRT}{100} = \frac{1000 \times 5 \times 10}{100} = 500$$

Amount after 10 years

$$A = P + S. I. = 1,000 + 500 = 1,500$$

Now after 10 years $P = 1,500$, $R = 5\%$ $k = 2,000$, $T = ?$

$S.I. = A - P$

$$= 2,000 - 1,500$$

$$= 500$$

$$T = \frac{SI}{P \times R} = \frac{500 \times 100}{1500 \times 5} = \frac{20}{3} = 6\frac{2}{3} \text{ Years}$$

Total time taken = 10 years + $6\frac{2}{3}$ years

$$= 16\frac{2}{3}$$

Question 4

A person borrows Rs. 5,000 for 2 years at 4% per annual simple interest. He immediately lends to another person at $6\frac{1}{4}\%$ per annual for 2 years find his gain in the transaction for year:

- (a) 112.50 (b) 225
 (c) 125 (d) 107.50

Answer: b

Explanation:

Case - 1

$P = 5,000$

$R = 4\%$ p.a.s.i

$T = 2$ years

$$SI = \frac{PRT}{100} = \frac{5000 \times 4 \times 2}{100} = 400$$

Case - 2

$P = 5,000$

$R = 6\frac{1}{4}\% = \frac{25}{4}\%$ p.a.s.i.

$T = 2$ Years

$$SI = \frac{PRT}{100} = \frac{5000 \times 25}{100 \times 4} \times 2 = 625$$

His gain = $625 - 400 = 225$

Question 5

If an amount is kept at S.I. it earns an interest of Rs. 600 in first two years but when kept at compound interest it earns an interest of 660 for the same period, then the rate of interest and principal amount respectively are

(a) 20%, Rs. 1,200

(b) 20%, Rs. 1,500

(c) 10%, Rs. 1,200

(d) 10%, Rs. 1,500

Answer: b**Explanation:**

Case - 1

Let P = X, R = R, T = 2, S.I. = 600

$$SI = \frac{PRT}{100} =$$

$$600 = \frac{XR \times 2}{100}$$

$$XR = \frac{600 \times 100}{2}$$

$$XR = 30,000$$

$$X = \frac{30,000}{R} \text{ ----- (1)}$$

Case - 2

P = X, R, T = 2, C.I. = 660

$$C.I. = P \left[\left(1 + \frac{R}{100} \right)^2 - 1 \right]$$

$$600 \left[\frac{30,000}{R} \right] \left[\left(1 + \frac{R}{100} \right)^2 - (1)^2 \right]$$

$$600 \left[\frac{30,000}{R} \right] \left[\left(1 + \frac{R}{100} + 1 \right) \left(1 + \frac{R}{100} \right) - 1 \right]$$

$$600 \left[\frac{30,000}{R} \right] \left[\left(2 + \frac{R}{100} + 1 \right) \left(1 + \frac{R}{100} \right) - 1 \right]$$

$$\left[\frac{600}{300} \right] = 2 + \left[\left(\frac{R}{100} \right) \right]$$

$$\frac{R}{100} = \frac{600}{300} - 2$$

$$\frac{R}{100} = \frac{600 \times 600}{600 \times 600}$$

$$\frac{R}{100} = \frac{300}{60}$$

$$R = \frac{60 \times 100}{300} = 20\%$$

Putting R = 20% in

$$X = \frac{30,000}{20}$$

$$X = \text{Rs. } 1,500$$

Hence:

$$P = x = \text{Rs. } 1500$$

$$R = 20\% \text{ p.a.}$$

Question 6**The future value of an annuity Rs. 1,000. Made annually for 5 year the interest of 14% compounded annually is:**

(a) 5610

(b) 6610

(c) 6160

(d) 5160

Answer: b**Explanation:**

Given, Annuity (A) = t 1,000

R = 14%

$$i = \frac{14}{100} = 0.14$$

Future value n = 5

$$A_{n, i} = \frac{A}{i} [(1 + i)^n - 1]$$

$$\frac{1000}{0.14} [(1 + 0.14)^5 - 1]$$

$$\frac{1000}{0.14} [1.92541 - 1]$$

$$\frac{1000}{0.14} [0.692541]$$

Rs. 6,610

NOV 2018

Question 1

If Rs. 10,000 is invested at 8% per year compound quarterly, then the value of the investment after 2 years is [given $(1 + 0.2)^8 = 1.171$]

- (a) 11,716.59 (b) 10,716.59
(c) 117.1659 (d) None

Answer: a

Explanation:

Given $P = 10,000$, $R = \frac{8\%}{4}$

$R = 2\%$ Quarterly

$T = 2 \times 4 = 8$ Quarter

Value of investment after 'T, years

$$A = P \left[1 + \frac{R}{100} \right]^T$$

$$10,000 \left[1 + \frac{2}{100} \right]^8$$

$$10,000(1+0.02)^8$$

$$10,000 \times (1.02)^8$$

$$10,000 \times 1.171659$$

$$11,716.59$$

Question 2

A bank pays 10% rate of interest; interest being calculated half yearly. A sum of Rs. 400 is deposited in the bank. The amount at the end of 1 year will be

- (a) 440 (b) 439
(c) 441 (d) 442

Answer: a

Explanation:

Given principal (P) = 400

$R = 10\%$ p.a.

$T = 1$ year

Amount after T years

$$A = P \left[1 + \frac{R}{100} \right]^T$$

$$= 400 \left[1 + \frac{10}{100} \right]^1$$

$$= 400(1.1)$$

$$= 440$$

Question 3

A Certain money doubles itself in 10 years. When deposited on simple interest. It would triple itself in_____

- (a) 20 Years
(c) 25 years
- (b) 15 years
(d) 30 years

Answer: a

Explanation:

Case - 1

Let Principal (P) = 100, Amount (A) = 200, R =? T = 10 Years

S. I. = A - P

= 200 - 100

= 100

$$R = \frac{SI \times 100}{P \times T}$$

$$= \frac{100 \times 100}{100 \times 10}$$

$$R = 10\%$$

Case - II

Let Principal (P) = 100

Amount (A) = 300

(T) = 10 Years

S.I. = A - P

= 300 - 100 = 200

$$T = \frac{SI \times 100}{P \times R}$$

$$\frac{200 \times 100}{100 \times 10} = 20 \text{ Years}$$

SHORTCUT

A 100 10 Years

B 200 10 years

C 300

Question4

A man deposited t 8,000 in a bank for 3 years at 5% per annum compound interest, after 3 years he will get

- (a) 8,800
(c) 9,200
- (b) 9,261
(d) 9,000

Answer: b

Explanation:

Given

P = 8000

R = 5% p.a.

T = 3 years

$$A = P \left[1 + \frac{R}{100} \right]^T$$

$$= 8000 \left[1 + \frac{5}{100} \right]^3$$

$$= 8000(1.05)^3$$

$$= 8,000 \times 1.05 \times 1.05 \times 1.05$$

$$= 9,261$$

Question5

If in two years' time a principal of Rs. 100 amounts to Rs. 121 when the interest at the rate of r% is compounded annually, then the value of r will be

- (a) 10.5
(c) 15
- (b) 10%
(d) 14

Answer: b**Explanation:**

Given,

Principal (P) = Rs. 100

Amount (A) = Rs. 121

Rate R = r% p.a.

Time T = 2 year

The amount after "T" year

$$A = P \left[1 + \frac{R}{100} \right]^T$$

$$121 = 100 \left[1 + \frac{r}{100} \right]^2$$

$$\frac{121}{100} = \left[1 + \frac{r}{100} \right]^2$$

$$\left(\frac{11}{10} \right)^2 = \left[1 + \frac{r}{100} \right]^2$$

On comparing

$$\frac{11}{10} = 1 + \frac{r}{100}$$

$$\frac{11}{10} - 1 = \frac{r}{100}$$

$$\frac{1}{10} = \frac{r}{100}$$

$$r = \frac{100}{10}$$

$$r = 10\%$$

Question6

A certain sum of money Q was deposited for 5 year and 4 months 4.5% simple interest and amounted to Rs 248, and then the value of Q is

- (a) 200 (b) 210
(c) 220 (d) 240

Answer: a**Explanation:**

Given Principal (P)

R = x

T = 4.5%

= 5 years 4 month

= 5 years + $\frac{4}{12}$ years= 5 years + $\frac{1}{3}$ years= $5\frac{1}{3}$ years= $\frac{16}{3}$ years

Amount after T years

A = P + S.I.

$$A = P + \frac{PRT}{100}$$

$$A = X + \frac{X \times 45 \times 16}{1000 \times 3}$$

$$248 = X + \frac{24X}{100}$$

$$124X = 24800$$

$$X = \frac{24800}{124} = 200$$

Question 7

A man invests an amount of Rs. 15,860 in the names of his three sons A, B and C in such a way that they get the same amount after 2, 3 and 4 years respectively. If the rate of interest is 5%, then the ratio of amount invested in the name of A, B and C is A.

- (a) 6: 4: 3 (b) 3: 4: 6
(c) 30: 12: 5 (d) None

Answer: a

Explanation:

Total amount invested = {15,860

Amount Invested into three persons (son's) A, B, C.

Let

Amount Invest in the Name of A = Rs. X

Amount Invest in the Name of B = Rs. Y

Amount Invest in the Name of C = Rs. Z

Then

Case - 1 For A

P = Rs. X, A = 5% T = 2 years

$$(S.I.)_1 = \frac{P_1 R_1 T_1}{100} = \frac{X \times 5 \times 2}{100} = \frac{10X}{100}$$

Case - 2 for B

P₂ = Rs. Y, R₂ = 5%, T₂ = 3 years

$$(S.I.)_2 = \frac{P_2 R_2 T_2}{100} = \frac{Y \times 5 \times 3}{100} = \frac{15Y}{100}$$

Case - 3 for C

P₃ = t z, R₃ = 5%, T₃ = 4 years

$$(S.I.)_3 = \frac{P_3 R_3 T_3}{100} = \frac{Z \times 5 \times 4}{100} = \frac{20Z}{100}$$

Given (S. I.)₁ = (S. I.)₂ = (S. I.)₃

$$\frac{10X}{100} = \frac{15Y}{100} = \frac{20Z}{100}$$

$$10X = 15Y = 20Z = K$$

$$10X = K, 15Y = K, 20Z = K$$

$$X = \frac{K}{10}, Y = \frac{K}{15}, Z = \frac{K}{20}$$

$$X : Y : Z = \frac{K}{10} : \frac{K}{15} : \frac{K}{20}$$

$$\frac{1}{10} : \frac{1}{15} : \frac{1}{20} = 60 \times \frac{1}{10} : 60 \times \frac{1}{15} : 60 \times \frac{1}{20}$$

$$6:4:3$$

Question 8

If the difference between the compound interest compounded annually and simple interest on a certain amount at 10% per annum for two years is 372, then the principal amount is

- (a) 37,200 (b) 37,000
(c) 37,500 (d) None of the above

Answer: a

Explanation:

For two year C.I. - S.I. = $P \left(\frac{R}{100} \right)^2$

$$372 = P \left(\frac{10}{100} \right)^2$$

$$372 = P (0.1)^2$$

$$P = \frac{372}{(0.1)^2} = \frac{372}{0.01} \times 100$$

$$= 37,200$$

Question 9

What is the net present value of piece of property which would be valued at 2 lakh at end of 2 years? (Annual rate of increase = 5%)

- (a) 1.81 lakh (b) 2.01 lakh
(c) 2.00 lakh (d) None of the above

Answer: a**Explanation:**

Let, Present value (P) = P

A = Rs. 2, 00,000

A = 5%

$$A = P \left[1 + \frac{R}{100} \right]^T$$

$$2, 00,000 = P \left[1 + \frac{5}{100} \right]^2$$

$$2, 00,000 = P (1.05)^2$$

$$P = \frac{2,00,000}{(1.05)^2} = \frac{2,00,000}{1.1025}$$

$$= 1, 81,405.896$$

$$= 1.81 \text{ lakhs}$$

Question 10

The effective rate of interest for one-year deposit corresponding to a nominal 7% rate of interest per annum convertible quarterly is:

- (a) 7% (b) 7.5%
(c) 7.4% (d) 7.18%

Answer: (D)**Explanation:**Given $R = \frac{7}{4}\%$ Quarterly = 1.75%

T = 1 x 4 Quarterly

= 4 Quarterly

$$\text{Effective Rate (E)} = \left[\left(1 + \frac{R}{100} \right)^T - 1 \right] \times 100\%$$

$$\left[\left(1 + \frac{1.75}{100} \right)^4 - 1 \right] \times 100\%$$

$$[(1 + 0.0175)^4 - 1] \times 100\%$$

$$[(1.0175)^4] \times 100\%$$

$$[1.07185 - 1] \times 100\%$$

$$0.0718 \times 100\%$$

$$= 7.18\%$$

Question 11

How much will Rs. 25,000 amount to in 2 years at Compound interest if the rates for the successive years are 4% and 5% per year.

- (a) 27,300 (b) 27,000
(c) 27,500 (d) None

Answer: a

Explanation:

Given principal (P) = 25000

$R_1 = 4\%$

$R_2 = 5\%$

T = 2 years

Amount after 'Rs' years

$$A = P \left[1 + \frac{R_1}{100} \right]^1 \left[1 + \frac{R_2}{100} \right]^1$$

$$A = 25000 \left[1 + \frac{4}{100} \right]^1 \left[1 + \frac{5}{100} \right]^1$$

$$= 25000 \left(1 + \frac{1}{25} \right) \left(1 + \frac{1}{20} \right)$$

$$= 25000 \left(\frac{26}{25} \right) \times \left(\frac{21}{20} \right)$$

$$= 27300$$

Question 12

Rs.8000 /- at 10% per annum interest compounded half yearly will become at the end of one year.

(a) Rs. 8800

(b) Rs. 8820

(c) Rs. 8900

(d) Rs. 9600

Answer: b**Explanation:**

Given P = 8000, $R = \frac{10}{2}\% = 5\%$, T = 1×2h.y, T = 2

$$A = P \left[1 + \frac{R}{100} \right]^T$$

$$= 8000 \left[1 + \frac{5}{100} \right]^2$$

$$= 8000 \left[\frac{21}{20} \right]^2$$

$$= 8000 \times \frac{21}{20} \times \frac{21}{20}$$

$$= 20 \times 21 \times 21$$

$$= 8820$$

Question13

The value of furniture depreciates by 10% a year, it the present value of the furniture in an office is Rs. 21,870, calculated the value of furniture 3 year ago

(a) 30,000/-

(b) 35,000/-

(c) 40,000/-

(d) 50,000/-

Answer: a**Explanation:**

Present value of furniture (A) = 21,870/-

Rate of Depreciation (R) = 10%

Time T = 3 year ago

Value of furniture 3 year ago = P

Scrap value after T years

$$A = P \left[1 - \frac{R}{100} \right]^T$$

$$21,870 = P \left[1 - \frac{10}{100} \right]^3$$

$$21,870 = P (0.9)^3$$

$$P = \frac{21,870}{0.729} = 30,000$$

MAY 2019

Question 1

A sum was invested for 3 years as per C.I and the rate of interest for first year is 9%, 2nd year is 6% and 3rd year is 3% p.a. respectively. Find the sum if the amount in three years is '550?

- | | |
|----------------|-------------|
| (a) Rs. 250 | (b) Rs. 300 |
| (c) Rs. 462.16 | (d) Rs. 350 |

Answer: c

Explanation:

Assuming (C) as option 1st year

$$A = P (1+i)^n$$

$$A = 462.16(1+0.09)^2$$

$$= 462.16(1.09)$$

$$503.7544$$

2ND year

$$A = 503.75(1+0.06)^1$$

$$= 503.75(1.06)$$

$$533.975$$

$$149.99 \text{ Or } 150$$

By taking 462.16 as our principal amount is matched as 550/-

Question 2

If $Pi^2 = \text{Rs.}96$ and $R = 8\%$ compounded annually then $P = \dots\dots\dots$.

- | | |
|------------|------------|
| (a) 14,000 | (b) 15,000 |
| (c) 16,000 | (d) 17,000 |

Answer: b

Explanation:

$$Pi^2 = \text{Rs.}96$$

$$R = 8\%$$

$$P \times (8\%)^2 = 96$$

$$P \times 64\% = 96$$

$$P = \frac{96}{64\%}$$

$$P = \frac{96}{0.64}$$

$$P = \frac{96 \times 100 \times 100}{96 \times 64}$$

$$P = \frac{100 \times 100}{8 \times 6}$$

$$P = 15000$$

Question 3

$P = \text{'5,000}$ $R = 15\%$ $T = 4\frac{1}{2}$ using $I = \frac{PRT}{100}$ then I will be

- | | |
|-----------|-------------------|
| (a) 3,375 | (b) 3,300 |
| (c) 3,735 | (d) None of these |

Answer: a

Explanation:

$$I = \frac{PTR}{100}$$

$$= 5000 \times \frac{4.5}{\alpha} \times \frac{15}{100}$$

$$= 3375$$

Question 4

A sum of money amounts to 6,200 in 2 years and 7,400 in 3 years and as per S.I. then the principal is.

- (a) 3,000 (b) 3,500
(c) 3,800 (d) None of these

Answer: c

Explanation:

$$A_2 = 6200 \rightarrow P + P \times R \times T = 6200$$

$$A_3 = 7400 \rightarrow P [1 + 2R] = 6200$$

$$P + P \times R \times T = 7400$$

$$P [1 + 3R] = 7400$$

$$P = 3800$$

Question 5

The effective rate of interest does not depend upon

- (a) Amount of Principal (b) Amount of interest
(c) Number of Conversion periods (d) None of these

Answer: a

Explanation:

The Effective Rate of interest does not depend upon amount of principal

Question 6

In simple interest if the principal is '2,000 and the rate and time are the Roots of the equations $x^2 - 11x + 30 = 0$ then the simple interest is -----

- (a) 500 (b) 600
(c) 700 (d) 800

Answer: b

Explanation:

$$P = 2000$$

$$R? \quad T?$$

$$X^2 - 11X + 30 = 0$$

$$X^2 - 6X - 5X + 30 = 0$$

$$X[X-6]-5[X-6] = 0$$

$$(X-5) = 0 \quad X = 5$$

$$(X-6) = 0 \quad X = 6$$

$$R = 5, \quad T = 6$$

$$\frac{P \times R \times T}{100} = 2000 \times \frac{5}{100} \times 6$$

$$= 600$$

Question 7

The certain sum of money became '692/- in 2 yrs and '800/- in 5 years then the principal Amount is -----

- (a) 520 (b) 620
(c) 720 (d) 820

Answer: b

Explanation:

2nd year = 692, 5th year = 800

Taking out difference

5th year - 2nd year = 800 - 692

3yr = 108

Int. for 1 year = $\frac{108}{3} = 36$

Now to calc. principle

= 692 - 2 × Int

= 692 - 2 × 36

= 692 - 72 = 620

Question 8

Determine the present value of perpetuity of Rs. 50,000 per month @ Rate of interest 12% p.a. is -----

(a) Rs. 45,00,000

(b) 50,00,000

(c) Rs. 55,00,000

(d) 60,00,000

Answer: b

Explanation:

Answer is b

$I = (r/100) \div \text{time}$

$PVA = p/i$

$i = (12/100) \div 12 \text{ months} = 0.01$

$PVA = 50,000/0.01 = 50,00,000$

Question 9

A person wants to lease out a machine costing Rs. 5, 00,000 for a 10 year period. It has fixed a rental of Rs. 51,272 per annum payable annually starting from the end of first year. Suppose rate of interest is 10% per annum, compounded annually on which money can be invested. To whom this agreement is favorable?

(a) Favour for lessee

(b) Favour for lessor

(c) Not for both

(d) Can't be determined

Answer: a

Explanation:

The Calculating Present value for lease

$$A = P \left[\frac{(1+i)^{-n} - 1}{i} \right]$$

$$A = 21,272 \left[\frac{(1+0.1)^{-10} - 1}{0.1} \right]$$

$$= 51,272 \left[\frac{(1.1)^{-10} - 1}{0.1} \right]$$

$$A = 315,044$$

Now by lessee total cost incurred today will be 3, 15,044 & cost of machine is 5, 00,000

So we will prefer lessee

Question10

Let a person invest a fixed sum at the end of each month in an account paying interest 12% per year compounded monthly. If the future value of this annuity after the 12th payment is Rs. 55,000 then the amount invested every month is?

(a) Rs. 4, 837

(b) Rs. 4,637

(c) Rs. 4,337

(d) Rs. 3337

Answer: c**Explanation:**

$$FV = C \times \left[\frac{(1+i)^n - 1}{i} \right]$$

$$55000 = C \times \left[\frac{(1+0.01)^{12} - 1}{0.12} \right]$$

$$= 4337$$

Question 11

A machine depreciates in value each year at 10% of its previous value and the end of 4th year value is Rs. 131220. Find the original value:

(a) Rs. 2,00,000

(b) Rs. 2,02,000

(c) Rs. 2,01,000

(d) Rs. 2,03,000

Answer: a**Explanation:**

Let value of the machine at the start was 100. Now, depreciate the value by 10% and 5% alternatively.

$$100 \Rightarrow 10\% \Rightarrow 90 \Rightarrow 5\% \Rightarrow 85.5 \Rightarrow 10\% \Rightarrow 76.96 \Rightarrow 5\% \Rightarrow 73.10 \text{ (at the end of 4th year.)}$$

Now, comparing,

$$73.10 = 146205$$

$$1 = 146205/73.10$$

$$100 = (146205 \times 100) / 73.10 = 2,00,006. \text{ (Approx).}$$

So, value at the start = Rs. 200000

NOV 2019**Question 1**

A man invests Rs. 12,000 at 10% p.a. and another sum of money at 20% p.a. for one year. The total investment earns at 14% p.a. simple interest the total investment is:

(a) Rs 8,000

(b) Rs. 20,000

(c) Rs. 14,000

(d) Rs. 16,000

Answer: (b)**Explanation:**

Let the another sum of money be x

So total investment Rs. (12,000 + x)

$$SI = \frac{P \times R \times T}{100}$$

According to question

$$\frac{12,000 \times 10 \times 1}{100} + \frac{x \times 20 \times 1}{100} = (12,000 + x) \times \frac{14}{100} \times 1$$

$$1,20,000 + 20x = 1,68,000 + 14x$$

$$6x = \text{Rs. } 48,000$$

$$x = \text{Rs. } 8,000$$

So total investment

$$= \text{Rs. } (12,000 + x)$$

$$= \text{Rs. } (12,000 + 8000)$$

$$= \text{Rs. } 20,000$$

Question 2

Let the two rates of interest be $r_1\%$, $r_2\%$

- (a) 0.4 (b) 4
(c) 0.004 (d) 18

Answer: (a)

Explanation:

$$SI = \frac{P \times R \times T}{100}$$

According to question

$$(SI)_1 - (SI)_2 = 18$$

$$1500 \times \frac{r_1}{100} \times 3 - 1500 \times \frac{r_2}{100} \times 3 = 8$$

$$\frac{4500}{100} (r_1 - r_2) = 18$$

$$(r_1 - r_2) = 0.4$$

So, the difference in their rates is 0.4.

Question 3

Find the effective rate of interest on payable half yearly at 5% p.a.

- (a) 5.06% (b) 4%
(c) 0.4% (d) 3%

Answer: (a)

Explanation:

Here, $R = 5\%$ $T = 1$ yr

Since interest is payable half yearly

$$R = \frac{5}{2}\% \text{ and } T = 1 \times 2 = 2 \text{ Year}$$

$$= \left[\left(1 + \frac{R}{100} \right)^T - 1 \right] \times 100$$

$$= \left[\left(1 + \frac{5}{2 \times 100} \right)^2 - 1 \right] \times 100$$

$$= [(1.025)^2 - 1] \times 100$$

$$= [0.050625] \times 100$$

$$= 5.0625\%$$

$$= 5.06\% \text{ (Approx.)}$$

Question 4

Find the effective rate of interest at 10% p.a. when interest is payable quarterly.

- (a) 10.38% (b) 5%
(c) 5.04% (d) 4%

Answer: (a)

Explanation:

Here; $R = 10\%$ $T = 1$ year

Since interest is payable quarterly

$$R = \frac{10\%}{4} \quad T = 1 \times 4 \text{ years}$$

$$= \left[\left(1 + \frac{r}{100} \right)^T - 1 \right] \times 100$$

$$= \left[\left(1 + \frac{10}{4 \times 100} \right)^4 - 1 \right] \times 100$$

$$= [(1.025)^4 - 1] \times 100$$

$$= 10.38\%$$

Question 5

What will be the population after 3 years when present population is Rs. 25,000 and populations increase at the rate of 3% in 1 year, at 4% in II year, and at 5% in III year?

- (a) Rs. 28,119 (b) Rs. 29,118
(c) Rs. 27,000 (d) Rs. 30,000

Answer: (a)

Explanation:

When population increase at the rate of $r_1\%$ in 1st year, $r_2\%$ in IInd year and $r_3\%$ in IIIrd year.

Population after 'years' is given by

$$A = P \left(1 + \frac{r_1}{100}\right) \left(1 + \frac{r_2}{100}\right) \left(1 + \frac{r_3}{100}\right)$$

Here, $P = 25,000$

$r_1 = 3\%$, $r_2 = 4\%$ $r_3 = 5\%$

$$\text{Population after 3 years} = 25,000 \left(1 + \frac{r}{100}\right) \left(1 + \frac{r}{100}\right) \left(1 + \frac{r}{100}\right)$$

= Rs. 28,119

Question 6

The value of scooter is Rs. 10,000 find its value after 7 years if rate of depreciation is 10% p.a.

- (a) 4,782.96 (b) 4,278.69
(c) 42,079 (d) 42,000

Answer: a

Explanation:

We know

$$A = P \left(1 - \frac{R}{100}\right)^T$$

Where, A scrap value

P Present value

R Rate of depreciation

T time

Here $P = 10,000$, $R = 10\%$, $T = 7$ years

$$A = 10,000 \left(1 - \frac{10}{100}\right)^7$$

$A = 4782.96$

So value of scooter is 4782.96 after 7 years

Question 7

SI = 0.125P at 10% p.a. Find time.

- (a) 1.25 years (b) 25 years
(c) 0.25 years (d) None

Answer: (a)

Explanation:

We know,

$$SI = \frac{p \times R \times T}{100}$$

Here, $SI = 0.125P$ $R = 10\%$

Put these values in the above formula

$$0.125P = P \times \frac{10}{100} \times T$$

$$T = \frac{0.125P \times 100}{10 \times P}$$

$$= 10 \times 0.125$$

$T = 1.25$ Years

Question 8

Scrap value of a machine valued at 10, 00,000, after 10 years within depreciation at 10% p.a.?

- (a) 348678.44 (b) 33,84,679.45
(c) 4,00,000 (d) 3,00,000

Answer: (a)

Explanation:

We Know,

$$A = P \left(1 - \frac{R}{100}\right)^T$$

Where A => Scrap value after 't' years.

P => Present value R => Rate of depreciation

Here, P = Rs. 10, 00,000, R = 10%, T = 10 Years

$$A = 10, 00,000 \left(1 - \frac{10}{100}\right)^{10} = 348678.44$$

So value of machine after 10 year will be 348678.44

Question 9

The difference between CI and SI for 2 years is 21. If rate of Interest 5% find principal

- (a) Rs. 8400 (b) Rs.4800
(c) Rs. 8,000 (d) Rs. 8,200

Answer:(a)

Explanation:

$$CI = P \left[\left(1 + \frac{R}{100}\right)^T - 1 \right] \quad SI = \frac{P \times R \times T}{100}$$

$$CI = P \left[\left(1 + \frac{R}{100}\right)^2 - 1 \right] \quad SI = \frac{P \times 5 \times 2}{100}$$

$$CI = P |1.1025 - 1|$$

$$CI = P (0.1025)$$

$$21 = 0.0025 P$$

$$P = Rs. \frac{21}{0.0025} = Rs. 8400$$

So principal is 8400

Question 10

Present value of a scooter is Rs. 7,290 if its value decreases every year by 10% then its value before 3 years is equal to:

- (a) 10,000 (b) 10,500
(c) 20,000 (d) 20,500

Answer:(a)

Explanation:

Let the value of the scooter be Rs. X before 3 years

Before three years, A (scrap value after 3 year) = Rs. 7,290

R = 10% (dep rate)

T = 3 years

$$A = P \left(1 - \frac{R}{100}\right)^T$$

$$7,290 = P \left(1 - \frac{R}{100}\right)^3$$

$$P = Rs. 10,000$$

DEC 2020**Question 1**

On what sum will the compound interest at 5% p.a for 2 years compounded annually be Rs.3,280?

- (a) Rs. 16,000
(b) Rs. 32,000
(c) Rs. 48,000
(d) Rs. 64,000

Answer: b

Explanation:

Let the sum be Rs. X

We Know that:

$$= P \left(1 + \frac{R}{100} \right)^n - P$$

$$= P \left(1 + \frac{R}{100} \right)^n - 1$$

$$3280 = x \left[\left(1 + \frac{R}{100} \right)^n - 1 \right]$$

$$3280 = x [1.05^2 - 1]$$

$$x = \frac{3280}{0.1025}$$

$$x = 32,000$$

Question 2

What sum of money will produce Rs.42,800 as an interest in 3 years and 3 months at 2.5% p.a simple interest?

- (a) Rs.3,78,000
(b) Rs.5,26,769
(c) Rs.4,22,000
(d) Rs.2,24,000

Answer: b

Explanation:

We know $I = P \times i \times t$

$$42,800 = P \times \frac{2.5}{100} \times 3 \frac{3}{12}$$

$$P = 5,26,769$$

Question 3

An amount P becomes Rs.5,100.5 and Rs.5,203 after second and fourth years respectively, at r% of interest per annum compounded annually. Thus, values of P and r are

- (a) Rs.5,000 and 1
(b) Rs.4,000 and 1.5
(c) Rs.6,000 and 2
(d) Rs.5,500 and 3

Answer: a

Explanation:

By option a

5000 as P & 1% = r

For 2 year

$$5000 + 1\% + 1\% = 5100.5$$

For 4 year

$$5000 + 1\% + 1\% + 1\% + 1\% = 5203$$

Question 4

A certain sum invested at 4% per annum compounded semi-annually amounts to Rs.1,

20,000 at the end of one year. Find the sum

- (a) 1,10,120 (b) 1,15,340
(c) 1,12,812 (d) 1,13,113

Answer: b

Explanation:

$$A_n = 1,20,000$$

$$n = 2 \times 1 = 2$$

$$i = 4 \times 1/2\% = 2\% = 0.02$$

$$P(\text{in Rs}) = ?$$

$$\text{We have } A_n = P(1+0.02)^2$$

$$1,20,000 = P(1.02)^2$$

$$= 1,15,340$$

Question 5

Rs. 2,500 is paid every year for 10 years to pay off a loan. What is the loan amount if interest rate be 14% per annum compounded annually?

- (a) 13,040.27 (b) 15,847.90
(c) 14,674.21 (d) 16,345.11

Answer: a

Explanation:

$$V = A.P. (n, i)$$

$$\text{Here } A = \text{Rs. } 2,500$$

$$n = 10$$

$$i = 0.14$$

$$V = 2,500 \times P (10, 0.14)$$

$$= 2,500 \times 5.21611 = \text{Rs. } 13,040.27$$

Therefore the loan amount is RS. 13,040.27

Question 6

The ratio of principal and the compound interest value for three years (compounded annually) is 216: 127. The rate of interest is

- (a) 0.1567 (b) 0.1777
(c) 0.1667 (d) 0.1588

Answer: c

Explanation:

Let the principal be P, then

Compound interest, CI :

$$\frac{P}{CI} = \frac{216}{127}$$

$$\Rightarrow CI = \frac{127}{216} P$$

$$CI = P \left[1 + \frac{R}{100} \right]^T - P$$

$$\Rightarrow \frac{127}{216} P = P \left[1 + \frac{R}{100} \right]^3 - P$$

$$\Rightarrow \frac{127}{216} = \left(1 + \frac{R}{100} \right)^3 - 1$$

$$\rightarrow \frac{127}{216} + 1 = \left(1 + \frac{R}{100}\right)^3$$

$$\rightarrow \frac{343}{216} = \left(1 + \frac{R}{100}\right)^3$$

$$\rightarrow 1 + \frac{R}{100} = \left(\frac{343}{216}\right)^{\frac{1}{3}}$$

$$\rightarrow 1 + \frac{R}{100} = \frac{7}{6}$$

$$\rightarrow \frac{R}{100} = \frac{7}{6} - 1$$

$$\rightarrow R = \frac{1}{6} \times 100$$

$$\rightarrow R = 16.67\% = 0.1667$$

Hence, 16.67% (Option C) is correct.

Question 7

Find the present value of Rs.1, 00,000 be required after 5 years if the rate of interest is 9% given that $(1.09)^5 = 1.5386$

(a) 78,995.98

(b) 64,994.20

(c) 88,992.43

(d) 93,902.12

Answer: b

Explanation:

Here $i = 0.09 = 9\%$

$n = 5$

$A_n = 10,000$

Required present value = $\frac{A_n}{(1+i)^n}$

$$= \frac{1,00,000}{(1 + 0.09)^5}$$

Rs. 64,994.20

Question 8

Suppose you deposit Rs.900 per month into an account that pays 14.8% interest compounded monthly. How much money will you get after 9 months?

(a) Rs. 8,511

(b) Rs. 9,000

(c) Rs. 9,200

(d) Rs. 1,000

Answer: a

Explanation:

Here, $P = \text{Rs. } 900$, $R = 14.8\%$ and $T = \frac{9}{12} = \frac{3}{4}$

$$A = P \left(1 + \frac{R}{100}\right)^{3/4}$$

$$A = P \left(1 + \frac{14.8}{100}\right)^{3/4}$$

$$A = 8,511$$

Question 9

An amount is lent at a nominal rate of 4.5% per annum compounded quarterly. What would be the gain in rupees over when compounded annually?

- (a) 0.56 (b) 0.45
(c) 0.76 (d) 0.85

Answer: c

Explanation:

Let the principal be Rs. 1 and rate is 4.5% per annum

Compounded Annually:-

$$A = P \left(1 + \frac{r}{100} \right)^n$$

Compounded Quarterly:-

$$A = P \left(1 + \frac{r}{100} \right)^{4n}$$

$$A = 1 \left(1 + \frac{4.5}{100} \right)^1 = \frac{104.5}{100} = 1.04500$$

$$A = 1 \left(1 + \frac{4.5}{100} \right)^4 = \frac{104.5}{100} = 1.04500$$

Gain = 0.00076

Now, gain for Rs. 1 = 0.00076

Gain for Rs. 1000 = 0.76

Question 10

Determine the present value of perpetuity Rs.10 per month for infinite period at an effective rate of interest of 14% p.a.?

- (a) Rs.657 (b) Rs.757
(c) Rs.857 (d) Rs.957

Answer: c

Explanation:

$$i = \frac{(r/100)}{T}$$

$$PVA = \frac{10}{0.01166}$$

$$i = \frac{(14/100)}{12}$$

$$= 857$$

Question 11

Which of the following statement is true?

- (a) F.V of ordinary annuity < F.V of annuity due (b) F.V of ordinary annuity > F.V of annuity due
(c) P.V of ordinary annuity > P.V of annuity due (d) None of these

Answer: a

Explanation:

F.V of ordinary annuity < F.V of annuity due

JAN 2021

Question 1

A certain sum amounted to Rs. 575 at 5% in a time which Rs. 750 amounted to Rs. 840 at 4% if the rate of interest is simple, find the sum.

- (a) Rs. 525 (b) Rs. 550
(c) Rs. 515 (d) Rs. 500

Answer: d

Explanation:

$$\text{Time} = \frac{90 \times 100}{750 \times 4} = 3 \text{ year}$$

$$\text{Sum} = \frac{100 \times A}{100 + rt}$$

$$\frac{100 \times 575}{100 + 3 \times 5} = 500$$

There is a direct relationship between the principal and the amount and is given by $\text{SUM} = (100 \times \text{Amount}) / (100 + rt)$

Question 2

Find the amount of compound interest, if an amount of Rs. 50,000 is deposited in a bank for one year at the rate of 8% per annum compounded semiannually.

- (a) Rs. 3,080 (b) Rs. 4,080
(c) Rs. 5,456 (d) Rs. 7,856

Answer: b

Explanation:

It is given that

Principal (P) = 50000

Rate of interest (r) = 8% p.a. = 4% semi-annually

Period (n) = $\frac{1}{2}$ years = 2 semi-annually

We know that

Amount = $P(1+r/100)^n$

Substituting the values

$$= 50000(1+4/100)^2$$

By further calculation

$$= 50000(26/25)^2$$

$$= 50000 \times \frac{26}{25} \times \frac{26}{25}$$

$$= 54,080$$

Here

Compound interest = A - P

Substituting the values

$$= 54,080 - 50000$$

$$= 4,080$$

Question 3

The population of a town increases by 2% of the population of the beginning of that year. The number of years by which the total increase in population would be 40% is

- (a) 7 years (b) 10 years
(c) 17 years (approx.) (d) 19 years (approx...)

Answer: c

Explanation:

lets assume that the initial population was P

now after a year population will be

$$= P \left[1 + \frac{2}{100} \right]$$

$$= P(102/100)$$

$$= 1.02P$$

Similarly after 2 years population will be

$$= 1.02 \times 1.02 \times P$$

So after n number of years population will be

$$= P \times (1.02^n)$$

now this population should be equal to $P+40\%P$, so

$$1.4P = P \times (1.02^n)$$

$$1.4 = 1.02^n$$

$$1.02^{17} = 1.02^n$$

$$\text{so } n = 17$$

that means after 17 years the total increase in the population will be 40% of that of initial population.

Question 4

Find the future value of annuity of Rs. 1,000 made annually for 7 years at interest rate of 14% compounded annually [Given that $1.14^7 = 2.5023$]

(a) Rs. 10,730.7

(b) Rs. 5,365.35

(c) Rs. 8,756

(d) Rs. 9,892.34

Answer: a

Explanation:

Annual Payment $A = \text{Rs. } 1000$

$$n = 7$$

$$i = 14\% = 0.14$$

$$A(7, 0.14) = 1000 \left[\frac{(1+0.14)^7 - 1}{0.14} \right] = 10,730.7$$

Question 5

Two equal amounts of money are deposited in two banks each at 15% p.a. for 3.5 years in the bank and for 5 years in the other. The difference between the interest amounts from the banks is Rs. 144. Find the sum.

(a) Rs. 620

(b) Rs. 640

(c) Rs. 820

(d) Rs. 840

Answer: b

Explanation:

$$\frac{144 \times 100}{(5 - 3.5) \times 15} = 640$$

Question 6

The simple interest on a sum at 4% p.a. for two years is Rs. 80. Find the compound interest on the same sum for the same period.

(a) Rs. 81.6

(b) Rs. 80.8

(c) Rs. 83.2

(d) Rs. 82.3

Answer: a

Explanation:

$$SI = \frac{PTR}{100} = \frac{80 \times 100}{8} = 1000$$

In CI with rate of interest = 4% and time = 2years

$$\text{Amount} = 1000 \times \frac{104}{100} \times \frac{104}{100} = 1081.6$$

$$\text{CI} = A - P = 1081.6 - 1000 = 81.6$$

Question 7

Which is a better investment 9% p.a. compounded quarterly or 9.1% p.a. simple interest?

- (a) 9% compounded (b) 9.1% S.I
(c) Both are same (d) Cannot be said

Answer: a

Explanation:

The better investment in the sense of more interest will be 9.0% compounded quarterly.

The formulas are

1. Future value = Principal $\times (1 + i)^t$ when the interest is compounded annually, and investment will be multiplied by $(1 + I)^t$, but in this case, $t = 1$, so the multiplier will be $1 + .0925 = 1.0925$.

Question 8

The effective rate of interest corresponding to nominal rate of 7% p.a. compounded quarterly is.

- (a) 7.5% (b) 7.6%
(c) 7.7% (d) 7.18%

Answer: d

Explanation:

$r = 7\%$ p.a i.e 1.75% per quarter (7/4).

$$\text{So } 1 + \text{reff} = (1.0175)^4 = 1.071859$$

implies reff = 7.1859

Question 9

Assuming that the discount rate is 7% p.a. how much would you pay to receive Rs. 200, growing at 5% annually forever?

- (a) Rs. 2,500 (b) Rs. 5,000
(c) Rs. 7,500 (d) Rs. 10,000

Answer: d

Explanation:

$$\frac{200}{0.07 - 0.05} = \frac{200}{0.02} = 10,000$$

Question 10

A man invested one-third of his capital at 7% one-fourth at 8% and the remainder at 10% if the annual income is Rs. 5610, the capital is

- (a) Rs. 4,400 (b) Rs. 5,500
(c) Rs. 6,600 (d) Rs. 5,800

Answer: c

Explanation:

Let the total capital be x . Then

$$\left(\frac{x}{3} \times \frac{7}{100} \times 1\right) + \left(\frac{x}{4} \times \frac{8}{100} \times 1\right) + \left(\frac{5x}{12} \times \frac{10}{100} \times 1\right) = 5610$$

$$= \frac{7x}{300} + \frac{x}{50} + \frac{x}{24} = 5610$$

$$= 51x = (5610 \times 600)$$

$$x = \left(\frac{5610 \times 600}{51} \right)$$

Question 11

A sum of money is lent at compound interest rate 20% p.a. two years. It would fetch Rs. 482 more if the interest is compounded half-yearly. Then the sum is.

- (a) Rs. 19,800 (b) Rs. 19,900
(c) Rs. 20,000 (d) Rs. 20,100

Answer: c

Explanation:

Let the sum of money lent out be Rs. x

In the 1st case:

$$A_1 = Rs \ x \left(1 + \frac{20}{100} \right)^2 = Rs. \frac{36x}{25} \therefore A = P \left(1 + \frac{r}{100} \right)^n$$

$$A_2 = Rs \ x \left(1 + \frac{20}{100 \times 2} \right)^{2 \times 2} = Rs. \frac{14641x}{10000} \therefore A = P \left(1 + \frac{r}{2 \times 100} \right)^{n \times 2} \text{ (half yearly)}$$

According to the question

$$\frac{14641x}{10000} - \frac{36x}{25} = 482$$

$$= \frac{14641x - 14400x}{10000} = 482$$

$$= 241x = 4820000$$

$$= x = 20000$$

\therefore The sum of money lent out = Rs.20,000

Question 12

Rs. 800 is invested at the end of each month in an account paying interest 5% per year compounded monthly. What is the future value of his annually after tenth payment?

(Given that $1.005^{10} = 1.0511$)

- (a) Rs. 4,444 (b) Rs. 8,756
(c) Rs. 3,491 (d) Rs. 8,176

Answer: d

Explanation:

$$A = Rs. 800$$

$$n = 10$$

$$i = 5\% \text{ p.a.} = 5/12 = \frac{5}{1200} \rightarrow 0.00416$$

Future value of annuity after 10 months is given by

$$A(n, i) = A \left[\frac{(1+i)^n - 1}{i} \right]$$

$$A(10, 0.00416) = 800 \left[\frac{(1+0.00416)^{10} - 1}{0.00416} \right]$$

$$= Rs. 8,176$$

Question 13

When 'i' denote the actual rate of interest in decimal, and n denote the number of conversion periods, the formula for computing the effective rate of interest E is given by.

- (a) $(1+i)^n$ (b) $(1+i)^n - 1$
(c) $1 - (1+i)^n$ (d) $(1+i)^{-n}$

Answer: b

Explanation:

$$(1 + i)^n - 1$$

Question 14

The present value of an Annuity immediate is the same as

- (a) Annuity regular for $(n - 1)$ years plus the initial receipt in the beginning of the period.
- (b) Annuity regular for $(n - 1)$ years initial receipt in the beginning of the period.
- (c) Annuity regular for $(n + 1)$ years.
- (d) Annuity regular for $(n + 1)$ years plus the initial receipt in the beginning of the period.

Answer: a

Explanation:

Annuity regular for $(n - 1)$ years plus the initial receipt in the beginning of the period.

JULY 2021

Question 1

A sum of ₹ 7500 amounts to ₹ 9075 at 10% p.a., interest being compounded yearly in a certain time. The simple interest (in ₹) on the same sum for the same time and the same rate is

- (a) 1000
- (b) 1250
- (c) 1800
- (d) 1500

Answer: Options (d)

Assuming throw trick

$$7500 + 10\% + 10\% = 9075$$

Means 7500 took 2 years to be 9075

$$\frac{7500 \times 2 \times 10}{100} = 1500$$

Question 2

A loan of ₹ 1, 02,000 is to be paid back in two equal annual instalments. If the rate of interest is 4% p.a., compounded annually, then the total interest charged (in ₹) under this instalment plan is

- (a) 6160
- (b) 8120
- (c) 5980
- (d) 7560

Answer: Options (a)

First let's call every instalment

$$(1.04)^2 \div 4 \text{ GT } \div = 1, 02,000 = \text{each instalment is } 54,080$$

$$2 \text{ Instalments is } 54,080 \times 2 = 1, 08,160$$

$$\text{Net Instalment Paid} = 1, 08,160 - 1, 02,000 = 6160$$

Question 3

If the desired future value after 5 years with 18% interest rate is ₹ 1,50,000, then the present value (in ₹) is (Given that $(1.18)^5 = 2.2877$)

- (a) 63,712
- (b) 65,568

(c) 53,712

(d) 41,712

Answer: Options (b) $65,568 + 18\% + 18\% + 18\% + 18\% + 18\% = 1, 50,000$ (approx.)**Question 23****What is the Compound interest (in ₹) on a sum of ₹ 12,600 for 1 ½ years at 20% per annum if the interest is compounded half yearly? (Nearest to a Rupee)**

(a) 4271

(b) 4171

(c) 4711

(d) 4117

Answer: Options (b)**Explanation:**

Given

$P = 12600$

$n = 1\frac{1}{2}$ Years = 3 Years

$r = \frac{20}{2} = 10\%$

We know that

$$A = P \left(1 + \frac{r}{100}\right)^n$$

$$= 12,600 \left(1 + \frac{10}{100}\right)^3$$

$$= 12,600 \times \frac{11}{10} \times \frac{11}{10} \times \frac{11}{10}$$

$$= 126 \times \frac{1331}{10}$$

$$= \frac{167706}{10}$$

$A = 16770.6$

Now,

$CI = A - P$

$$= 16770.6 - 12600$$

$$= 4171$$
 (Approx.)

Question 4**A sum of ₹ x amounts to ₹ 27,900 in 3 years and to ₹ 41,850 in 6 years at a certain rate percent per annum, when the interest is compounded yearly. The value of x is**

(a) 16080

(b) 18600

(c) 18060

(d) 16800

Answer: Options (b)**Explanation:**

Let the principal be ₹ x and after three years, it becomes Rs. 27,900 and after 6 years it becomes 41,850

$$\rightarrow \frac{27,900}{x} = \frac{41,850}{27,900}$$

$$\rightarrow X = \frac{27,900 \times 27,900}{41,850}$$

$$\rightarrow X = 18600$$

Question 5

If the normal rate of growth is 17% and inflation is 9% for the five years. Let P be the Gross Domestic Product (GPD) amount at the present year then the projected real GDP after 6 years is

- (a) 1.587 P (b) 1.921 P
(c) 1.403 P (d) 2.15 P

Answer: Options (a)

Explanation:

Growth is 17%

Inflation is 9%

Net Growth = 8%

Taking P = 100, T = 6 year, R = 8%

$100 + 8\% + 8\% + 8\% + 8\% + 8\% + 8\% = 158.687$

$1.587 P = 100$

$1.587 \times 100 = 158.7$ (Approx.)

Question 6

If a person bought a house by paying ₹ 45,00,000 down payment and ₹ 80,000 at the end of each year till the perpetuity assuming the rate of interest as 16%, the present value of house (in ₹) is given as

- (a) 47,00,000 (b) 45,00,000
(c) 57,80,000 (d) 50,00,000

Answer: Options (d)

$$\frac{80,000}{0.16} = [\text{Perpetuity Formula}]$$

= 5,00,000 is to be deposited today

$45,00,000 + 5,00,000 = 50,00,000$

Question 7

Let the operating profit of a manufacturer for five years given as:

Year	1	2	3	4	5	6
Operating profit {in lakh ₹}	90	100	106.4	107.14	120.24	157.35

Then the operating profit of Compound Annual Growth Rate (CAGR) for year 6 with respect to years 2 is given at

- (a) 9% (b) 12%
(c) 11% (d) 13%

Answer: Options (b)

For CAGR we use very easy CI formula

$90 + 12\% + 12\% + 12\% + 12\% + 12\% = 158.61$

(Approx. 15.7)

Question 8

If discount rate is 14% per annum, then how much a company has to pay to receive ₹ 280 growing at 9% annually forever.

- (a) ₹ 5,600 (b) ₹ 2,800
(c) ₹ 1,400 (d) ₹ 4,200

Answer: Options (a)

$$\frac{R}{i - g} = \frac{280}{0.14 - 0.09} = \frac{280}{0.05} = 5600$$

Question 9

The effective rate of return for 24% per annum convertible monthly is given as

- (a) 24% (b) 26.82%
(c) 18% (d) 24.24%

Answer: Options (b)

ER from Tricks

$$100 + 2\% + 2\% + 2\% + 2\% + 2\% + 2\% + 2\% + 2\% + 2\% + 2\% + 2\% + 2\% + 2\% + 2\% \Rightarrow 26.82\%$$

Question 10

If the cost of capital be 12% per annum, then the net present value (in nearest ₹) from the given cash flow is given as

Year	1	2	3	4
Operating profit {in thousand ₹}	(100)	60	40	50

- (a) 31048 (b) 34185
(c) 51048 (d) 24187

Note: Correct Ans. is Rs. 21,048/- by taking the nearest value option D is preferable

Answer: Options (d)

Question 11

A certain sum amounts to ₹ 15748 in 3 years at simple interest at r% p.a. The same sum amounts to ₹ 16,510 at (r+2) % p.a. simple interest in the same time. What is the value of r?

- (a) 10% (b) 8%
(c) 12% (d) 6%

Answer: Options (b)

Question 12

What is difference (in ₹) between the simple interest and the compound interest on a sum of ₹ 8,000 for $2\frac{2}{5}$ years at the rate of 10% p.a., when the interest is compounded yearly?

- (a) 135.75 (b) 129.50
(c) 151.75 (d) 147.20

Answer: Options (d)

Question 13

The future value of annuity of ₹ 2,000 for 5 years at 5% compounded annually is given (in nearest ₹) as

- (a) 51051 (b) 02021
(c) 15624 (d) 61254

Note: Correct Ans is Rs. 11,051/- by taking the nearest value option C is Preferable

Answer: Options (c)

DEC 2021

Question 1

Mr. X wants to accumulate Rs. 50,000 at the end of 10 years. Then how much amount is required to invested every year if interest is compounded annually at 10%? (Given that $P(10,0.10) = 15.9374298$)

- (a) Rs. 3,13,726.87 (b) 4,13,726.87
(c) Rs. 3,53,726.87 (d) 4,53,726.87

Answer: a

Explanation:

Given FVAR = Rs 50,00,000; t= 10 years; i= 0.10; NOCPPY= 1; A=?

$$FVAR = A \left[\frac{\left(1 + \frac{i}{NOCPPY}\right)^{tx NOCPPY} - 1}{\frac{i}{NOCPPY}} \right]$$

$$A = \left[\frac{\left(1 + \frac{FVAR}{NOCPPY}\right)^{tx NOCPPY} - 1}{\frac{i}{NOCPPY}} \right]$$

$$A = \frac{50,00,000}{\left[\frac{\left(1 + \frac{0.10}{1}\right)^{10 \times 1} - 1}{\frac{0.10}{1}} \right]}$$

$$A = \frac{50,00,000}{15.9374298} = 3,13,726.87$$

Question 2

Rahul invested Rs 70,000 in a bank at the rate of 6.5% p.a. simple interest rate. He received Rs.85,925 after the end of term. Find out the period for which sum was invested by Rahul.

- (a) 2 years (b) 3 years
(c) 3.5 yeras (d) 2.5 years

Answer: c

Explanation:

Here, Principle (P) = 70,000

Rate (R) 6.5% p.a.

Amount (A) = 85,925, T= ?

S.I. A-P

$$= 85,925 - 70,000$$

$$= 15,925$$

$$T = \frac{S.I. \times 100}{P \times R} = \frac{15,925 \times 1000}{7000 \times 6.5}$$

$$= 3.5 \text{ year.}$$

Question 3

A company needs Rs. 10,000 in five years to replace as equipment. How much (inRs) should be invested now at an interest rate of 8% p.a. is order to provide for this equipment?

- (a) 6000 (b) 6805
(c) 10,000 (d) 11000

Answer:

Explanation:

We have A= Rs10,000; t = 5 years; i= 0.08; NOCPPY = 1; P=?

$$A = P \left(1 + \frac{i}{NOCPPY} \right)^{t \times NOCPPY}$$

$$P = \left[\frac{A}{\left(1 + \frac{i}{NOCPPY} \right)^{t \times NOCPPY}} \right]$$

$$= \left[\frac{10,000}{\left(1 + \frac{0.08}{1} \right)^{5 \times 1}} \right] = 6,805$$

Question 4

R needs money to pay Rs. 5,00,000 in 10 years. He invested a sum in a scheme at 9% rate of interest compounded half yearly. How much amount he invested? ($1.046^{20} = 2.41171$)

- (a) 3,07,321 (b) 2,70,321
(c) 2,07,321 (d) 3,40,321

Answer: c

Explanation:

$$A = P \left(1 + \frac{I}{NOCPPY} \right)^{t \times NOCPPY}$$

$$= P = \frac{5,00,000}{\left(1 + \frac{0.09}{2} \right)^{10 \times 2}}$$

$$= P = \frac{5,00,000}{(1.045)^{20}}$$

$$= P = \frac{5,00,000}{2.41171}$$

$$= P = 2,07,321$$

Question 5

An amount is lent at R% simple interest for R years and the simple interest amount was one-fourth of the principal amount. Then R is _____

- (a) 5 (b) 6
(c) $5 \frac{1}{2}$ (d) $6 \frac{1}{2}$

Answer: a

Explanation:

We know that I = Pot

$$\text{Given: } I = \frac{P}{4}; i = \frac{R}{100}; t = R$$

$$I = Pit$$

$$\frac{P}{4} = P \times \frac{R}{100} \times R$$

$$\frac{1}{4} = \frac{R^2}{100}$$

$$100 = 4R^2$$

$$R^2 = \frac{100}{4} = 25$$

$$R = \sqrt{25} = 5$$

Question 6

A sum of money is put at 20% compound interest rate p.a. At which year the aggregated amount just exceeds the double of the original sum?

- (a) 6 (b) 5
(c) 4 (d) 3

Answer: c

Explanation:

$i=0.20$; $P=100$; $\text{NOCPY}= 1$; $t=?$

$$A = P \left(1 + \frac{i}{\text{NOCPY}} \right)^{t \times \text{NOCPY}}$$

Try the options.

Option (a) - 6

$$A = 100 \left(1 + \frac{0.20}{1} \right)^{6 \times 1} = 298.5894$$

Option (b) - 5

$$A = 100 \left(1 + \frac{0.20}{1} \right)^{5 \times 1} = 248.832$$

Option (c) - 4

$$A = 100 \left(1 + \frac{0.20}{1} \right)^{4 \times 1} = 207.36$$

Option (d) - 3

$$A = 100 \left(1 + \frac{0.20}{1} \right)^{3 \times 1} = 172.8$$

Therefore, option (c) is the answer.

Question 7

The present value of an annuity of Rs. 25,000 to be received after 10 years at 6% per annum

compounded annually is Rs _____.

$(1.06^5 = 1.33823)$

(a) Rs. 15,960

(b) Rs. 13,960

(c) Rs. 11,960

(d) Rs. 17,960

Answer: b

Explanation:

The language of this question is wrong. The word "annuity" should not have been there. Also, the given information $(1.06^5 = 1.33823)$ is of no use.

$$P = \frac{A}{\left(1 + \frac{A}{NOCPY}\right)^{t \times NOCPY}}$$

$$P = \frac{25,000}{\left(1 + \frac{0.06}{1}\right)^{10 \times 1}}$$

$$= P = 13,959.87 = 13,960$$

JUNE 2022

Question 1

₹ 2500 is paid every year for 10 years to pay off a loan. What is the loan amount if interest rate be 14% per annum compounded annually?

(a) ₹ 15,841.90

(b) ₹ 13,040.27

(c) ₹ 14,674.21

(d) ₹ 14,010.90

Answer: Options (a)

Explanation:

Annuity (A) = 2,500

n = 10yrs.

R = 14%

$$I = \frac{R}{100} = \frac{14}{100} = 0.14$$

Present value

$$\begin{aligned} v &= \frac{A \left[\frac{(1+i)^n - 1}{i} \right]}{i \left[\frac{(1+i)^n - 1}{i} \right]} \\ &= \frac{2,500 \left[\frac{(1+0.14)^{10} - 1}{0.14} \right]}{0.14 \left[\frac{(1+0.14)^{10} - 1}{0.14} \right]} \\ &= \frac{2,500 \left[\frac{(1.14)^{10} - 1}{0.14} \right]}{0.14 \left[\frac{(1.14)^{10} - 1}{0.14} \right]} \\ &= \frac{2,500 \left[\frac{3.707221 - 1}{0.14} \right]}{0.14 \left[\frac{3.707221 - 1}{0.14} \right]} \\ &= \frac{2,500 \times 2.70721}{0.14 \times 3.707221} \\ &= 13,040.27 \end{aligned}$$

Question 2

₹ 200 is invested at the end of each month in an account paying interest 6% per year compounded monthly. What is the future value of this annuity after 10th payment?

(a) ₹ 2,044

(b) ₹ 12,044

(c) ₹ 2,040

(d) ₹ 12,000

Answer: Options (a)**Explanation:**

Given Annuity (A) = ₹ 200

n = 10, R = 6% p.a.

 $i = \frac{6}{12} \% \text{ per month}$

i = 0.005

$$\begin{aligned} \text{Future value } A(n, i) &= \frac{A}{i} [(1+i)^n] - 1 \\ &= \frac{200}{0.005} [(1+0.005)^{10}] - 1 \\ &= \frac{200}{0.005} [1.0511] - 1 \\ &= 200 \times 10.22 \\ &= ₹ 2,044 \end{aligned}$$

Question 3**In How much time a sum of amount doubles at simple interest at 12.5% rate?**

(a) 7 year

(b) 8 year

(c) 9 year

(d) 10 year

Answer: Options (b)**Explanation:**

Let Principal (P) = 100

(A) = 200

(R) = 12.5%

T = ?

S.I = A - P

= 200 - 100

= 100

$$(\text{Time}) T = \frac{S.I \times 100}{P \times R} = \frac{100 \times 100}{100 \times 12.5} = 8 \text{ years}$$

Question 4**Anshika took a loan of ₹ 1,00,000 @ 8% for 5 years. What amount will she pay if she wants to pay the whole amount in five equal instalments?**

(a) ₹ 25,405.63

(b) ₹ 26,045.68

(c) ₹ 28,045.50

(d) None

Answer: Options (a)**Explanation:**

V = 10000

R = 8%

 $i = \frac{8}{100} = 0.08$

A = ?, n = 5

Present Value

$$V = \frac{A}{i} \left[\frac{(1+i)^n - 1}{(1+i)^n} \right]$$

$$100000 = \frac{A}{0.08} \left[\frac{(1+0.08)^5 - 1}{(1+0.08)^5} \right]$$

$$100000 \times 0.08 = A \left[\frac{(1.08)^5 - 1}{(1.08)^5} \right]$$

$$8000 = \frac{A \times 0.469328}{1.469328}$$

$$8000 = A \times 0.319417$$

$$8000 = \frac{8000}{0.319417}$$

$$= 25,045.63$$

Question 5

Ankit invests ₹ 3,000 at the end of each quarter receiving interest @7% per annum for 5 years. What amount will be receive at the end of the period?

(a) ₹ 71,200.20

(b) ₹ 71,104.83

(c) ₹ 7,204.83

(d) None

Answer: Options (b)**Explanation:**

Given Annuity

(A) = 3000

$$R = \frac{7}{4}\% = 1.75\%$$

$$I = \frac{R}{100} = \frac{1.75}{100} = 0.0175$$

n = 5 years

= 5 × 4 Quarter

= 20 Quarter

$$\text{Future Value } A_{(n, i)} = \frac{A}{i} [(1 + i)^n - 1]$$

$$= \frac{3000}{0.0175} [(1 + 0.0175)^{20} - 1]$$

$$= \frac{3000}{0.0175} [(1.0175)^{20} - 1]$$

= 71,104.83

Question 6

The effective rate of interest corresponding a normal rate of 7% p.a. convertible quarterly.

(a) 7%

(b) 7.5%

(c) 5%

(d) 7.18%

Answer: Options (d)**Explanation:**

In interest is paid Quarterly

$$R = \frac{7}{4}\% = 1.75\%$$

T = 1 years = 1 × 4 Quarterly

= 4 Quarterly

Effective Rate

$$E = \left[\left(1 + \frac{R}{100} \right)^T - 1 \right] \times 100$$

$$= \left[\left(1 + \frac{1.75}{100} \right)^4 - 1 \right] \times 100$$

$$= [(1 + 0.0175)^4 - 1] \times 100$$

$$= [(1.0175)^4 - 1] \times 100$$

$$= [1.0781 - 1] \times 100$$

$$= 0.0781 \times 100$$

$$= 7.18\%$$

Question 7

Assuming that the discount rate is 7% p.a. How much would pay to receive ₹ 200, rowing at 5% annually for ever?

- (a) ₹ 2500 (b) ₹ 5000
(c) ₹ 7,500 (d) ₹ 10000

Answer: Options (d)

Explanation:

Discount rate (i) = 7% p.a = 0.07

growing rate (g) = 5% annually = 0.05

(R) = ₹ 200

Present value of growing perpetuity

$$\begin{aligned} PVA &= \frac{R}{i-g} \\ &= \frac{200}{0.07-0.05} \\ &= \frac{200}{0.02} \\ &= 10000 \end{aligned}$$

Question 8

A company establishes a sinking fund to provide for the payment ₹ 2,00,000 debt maturity in 20 years contribution to the fund are to be made at the end of every year. Find amount of each deposit of interest is 10% per annum?

- (a) ₹ 3,592.11 (b) ₹ 3,492.11
(c) ₹ 3,392.11 (d) None

Answer: Options (b)

Explanation:

$A_{(n,i)} = 2,00,000$

$R = 10\%, i = \frac{10}{100} = 0.1$

$A_{(n,i)} = \frac{A}{i} [(1+i)^n - 1]$

$200000 = \frac{A}{0.1} [(1+0.1)^{20} - 1]$

$200000 \times 0.1 = A [(1.1)^{20} - 1]$

$20000 = A [6.7275 - 1]$

$20000 = A \times 5.7275$

$$A = \frac{20000}{5.7275},$$

$$A = 3492.11$$

Question 9

The CAGR of initial value of a investment of ₹ 15,000 and final value of ₹ 25,000 in 3 years is:

- (a) 19% (b) 18.56%
(c) 17.56% (d) 17%

Answer: Options (b)

Explanation:

Initial value (V_{t_0}) = 15000

Final Value (V_{t_n}) = 25000

$$T_n - t_0 = 3$$

$$\begin{aligned} \text{CAGR}(0, 3) &= \left[\left(\frac{V_{tn}}{V_{t0}} \right)^{\frac{1}{tn-t_0}} - 1 \right] \times 100 \\ &= \left[\left(\frac{25000}{15000} \right)^{\frac{1}{3}} - 1 \right] \times 100 \\ &= \left[\left(\frac{5}{3} \right)^{\frac{1}{3}} - 1 \right] \times 100 \\ &= [(1.66)^{1/3} - 1] \times 100 \\ &= [1.1856 - 1] \times 100 \\ &= 0.1856 \times 100 = 18.56 \end{aligned}$$

Question 10

ABC Ltd. wants to lease out an asset costing ₹ 3,60,000 for a five year period. It has a fixed rental of ₹ 1,05,000, per annum payable annually starting from the end of first year. Suppose rate of interest is 14% per annum compounded annually on which money can be invested by the company. Is this agreement favourable to the company?

- (a) Yes (b) No
(c) It depends (d) None of the above

Answer: Options (a)

Explanation:

$$\text{Given, } A = 105000, n = 5, i = \frac{14}{100} = 0.14$$

Present Value

$$\begin{aligned} V &= A \cdot P(n, i) \\ &= 105000 \times P(5, 0.14) \\ &= 105000 \times 3.43308 \\ &= 360473.40 \end{aligned}$$

Which is greater than the initial cost of the asset (360000) and leasing is favourable and Preferable.

DEC 2022

Question 1

A machine worth Rs. 4,90,740 is depreciated at 15% on its opening value each year. When its value would reduce to Rs. 2,00,000?

- a) 5 years 5 months (b) 5 years 6 months
c) 5 years 7 months (d) 5 years 8 months

Answer: Options (b)

Explanation:

Initial price = 490740

Final = 2,00,000

$$\text{After 1 year} = 490740 \left(1 - \frac{15}{100} \right)$$

Opening Value of 2nd year

$$\text{After } n \text{ year} = 490740 \left(1 - \frac{15}{100} \right)^n - 200000$$

$$= 490740 \times \left(\frac{17}{20} \right)^n - 200000$$

$$0.85^n = \frac{200000}{490740}$$

$$0.85^n = 0.407$$

$$n \log 0.85 = \log 0.407$$

$$n = \frac{\log 0.407}{\log 0.85}$$

$$n = 5.5318$$

n = 5 Years 6 months

Question 2

If Rs. 64 Amount to Rs. 83.20 in 2 years, what will Rs. 86 Amount to in 4 years at the same Rate percent per annum?

a) Rs. 137.60

b) Rs. 147.60

c) Rs. 145.34

d) Rs. 117.60

Answer: Options (b)

Explanation:

$$P_1 = \text{Rs. } 64, A_1 = 83.2, T_1 = 2$$

Let Rate be R.

$$A = P \left(1 + \frac{RT}{100} \right)$$

$$83.2 = 64 \left(1 + \frac{2R}{100} \right)$$

$$\frac{83.2}{64} = 1 + \frac{2R}{100}$$

Rate = 15%

Now,

$$P_2 = 86$$

$$T_2 = 4$$

R = 15%

$$A = P \left(1 + \frac{RT}{100} \right)$$

$$A = 86 \left(1 + \frac{15 \times 4}{100} \right)$$

$$A = 137.60$$

Question 3

Raju invests Rs. 20,000 every year in a deposit scheme starting from today for next 12 years. Assuming that interest rate on this deposit is 7% per annum compounded annually. What will be the future value of this annuity? Given that $(1 + 0.07)^{12} = 2.25219159$.

a) Rs. 540,526

b) Rs. 382,813

c) Rs. 643,483

d) Rs. 357,769

Answer: Options (b)

Explanation:

By Trick:

$$(167) \times = = \boxed{13} - 1 \div 0.7$$

$$= \text{Rs. } 382,813$$

Question 4

Mr. A invested Rs. 10,000 every year for next for 3 years at the interest rate of 8 percent per annum compounded annually. What is future value of the annuity?

a) 32644

b) 32464

c) 34264

d) 36442

Answer: Options (b)**Explanation:**

Step-1: Calculate future value as though it is an ordinary annuity

Future value of the annuity as if it is an ordinary annuity

$$=10,000[(1+0.08)^3-1]/0.08$$

$$=10,000 \times 0.2597$$

$$=\text{Rs. } 2597.12$$

Step-2: Multiply the result by (1+i)

$$=32464$$

Question 5

Mr. Prakash invested money in two schemes 'A' and 'B' offering compound interest at the rate of 8% and 9% per annum respectively. If the total amount of interest accrued through these two schemes together in two years was Rs. 4818.30 and total amount invested was Rs. 27,000. What was the amount invested in scheme 'A'?

a) Rs. 12,000

b) Rs. 12,500

c) Rs. 13,000

d) Rs. 13,500

Answer: Options (a)**Explanation:**

Rs (27000-x)

$$\therefore x \left(1 + \frac{8}{100}\right)^2 - 1 + (27000 - x) \left(1 + \frac{9}{100}\right)^2 - 1 = 4818.30$$

$$\Rightarrow \left(x + \frac{104}{625}\right) + \frac{1881(27000-x)}{10000} = \frac{481830}{100}$$

$$\Rightarrow 1664x + 1881(27000-x) = 48183000$$

$$\Rightarrow (1881x - 1664x) = 50787000 - 48183000$$

$$\text{Or } 217x = 2604000$$

$$\text{Or } x = 12000\text{Rs}$$

Question 6

A sum of money invested of compound interest doubles itself in four years. In how many years it becomes 32 times of itself at the rate of compound interest.

a) 12 years

b) 16 years

c) 20 years

d) 24 years

Answer: Options (c)**Explanation:**

$$A = P \left(1 + \frac{R}{100}\right)^T$$

$$2x = x \left(1 + \frac{R}{100}\right)^4$$

$$2 = \left(1 + \frac{R}{100}\right)^4$$

$$1 + \frac{R}{100} = 2^{1/4}$$

$$32x = x \left(1 + \frac{R}{100}\right)^T$$

$$\therefore 1 + \frac{R}{100} = 2^{1/4}$$

$$\therefore 32 = 2^{T/4}$$

$$2^5 = 2^{T/4}$$

$$5 = T/4$$

$$T = 5 \times 4$$

T = 20 Years

Therefore, in 20 years the principal amount will become 32 times to itself.

Question 7

A farmer borrowed Rs. 3600 at the rate of 15% simple interest per Annum. At the end of 4 years, he cleared this account by paying Rs. 4000 and a cow. The cost of the cow is:

- a) Rs. 1000 b) Rs. 1200
c) Rs. 1550 d) Rs. 1760

Answer: Options (d)

Explanation:

SI for 4 years = Rs. $(3600 \times 15 \times 4) / 100$ = Rs. 2160

Amount after 4 years = Rs. $(3600 + 2160)$ = Rs. 5760

Cost of goat = Rs. $(5760 - 4000)$ = Rs. 1760

Question 8

How much amount is required to be invested every year so as to accumulate Rs. 5,00,000 at the end of 12 years if interest is compounded annually at 10%? (Where A(12, 0.1) = 21.384284)

- a) Rs. 23381.65 b) Rs. 24385.85
c) Rs. 26381.65 d) Rs. 28362.75

Answer: Options (a)

Explanation:

By Trick:

$$(1.1)^x = \boxed{13} \div 1 \div 0.1 \div = 5,00,000$$

= Rs. 23381.65

Question 9

The effective annual rate of interest corresponding to a normal rate of 6% per annum payable half yearly is:

- a) 6.06% b) 6.07%
c) 6.08% d) 6.09%

Answer: Options (d)

Explanation:

Amount of Rs.100 for 1 year when compounded half yearly}

$$= Rs \left[100 \times \left(1 + \frac{3}{100} \right)^2 \right] = Rs. 106.09$$

$$\therefore \text{Effective rate} = (106.09 - 100)\% = 6.09\%$$

Question 10

10 years ago the earning per share (EPS) of ABC Ltd. was Rs. 5 share. Its EPS for this year is Rs. 22. Compute at what rate, EPS of the company grows annually?

- a) 15.97% b) 16.77%
c) 18.64% d) 14.79%

Answer: Options (b)

Explanation:

By option b

$$5 + 16.77\% + 16.77\% + 16.77\% + 16.77\% + 16.77\% + 16.77\% + 16.77\% + 16.77\% + 16.77\% = 23 \text{ Approx}$$

So, 16.77% is answer

Question 11

The difference between compound interest and simple interest on an amount of Rs. 15,000 for 2 years is Rs. 96. What is the rate of interest per annum?

- | | |
|--------|--------|
| a) 9% | b) 8% |
| c) 11% | d) 10% |

Answer: Options (b)

Explanation:

$$15000 \times \left(1 + \frac{R}{100}\right)^2 - 15000 - \left(\frac{15000 \times R \times 2}{100}\right) = 96$$

$$= R = 8\%$$

Question 12

Rs. 5,000 is invested every month end in an account paying interest @ 12% per annum compounded monthly. What is the future value of this annuity just after making 11th payment?

(Given that $(1.01)^{11} = 1.1156$)

- | | |
|---------------|---------------|
| a) Rs. 57,800 | b) Rs. 56,100 |
| c) Rs. 56,800 | d) Rs. 57,100 |

Answer: Options (a)

Explanation:

$$A = \text{Rs. } 5000$$

$$n = 11$$

$$i = 12\% \text{ p.a.} = 12/12\% \text{ per month} = 0.010$$

Future value of annuity after 10 months is given by

$$A(n, i) = A \left[\frac{(1+i)^n - 1}{i} \right]$$

$$A(11, 0.010) = 5000 \left[\frac{(1+0.010)^{11} - 1}{0.010} \right]$$

$$= \text{Rs. } 57,800$$

Question 13

A sum of money doubles itself in 4 years at certain compound interest rate. In how many years this sum will become 8 times at same compound interest rate?

- | | |
|-------------|-------------|
| a) 12 years | b) 14 years |
| c) 16 years | d) 18 years |

Answer: Options (a)

Explanation:

$$A = P \left(1 + \frac{R}{100}\right)^2$$

$$2x = x \left(1 + \frac{R}{100}\right)^2$$

$$\left(1 + \frac{R}{100}\right) = 2^{1/4}$$

$$8x = x \left(1 + \frac{R}{100}\right)^2$$

$$\left(1 + \frac{R}{100}\right) = 2^{1/4}$$

$$8x = 2^{t/4}$$

$$2^3 = 2^{t/4}$$

$T/4 = 3$
 $T = 12$ Years

Question 14

Sinking fund factor is the reciprocal of :

- a) Present value interest factor of a single cash flow
- b) Present value interest factor of an annuity
- c) Future value interest factor of an annuity
- d) Factor value interest factor of a single cash flow

Answer: Options (b)

Explanation:

The present value interest factor of an annuity is used to calculate the present value of a series of future annuities

CHAPTER - 5 BASIC CONCEPTS OF PERMUTATIONS AND COMBINATIONS

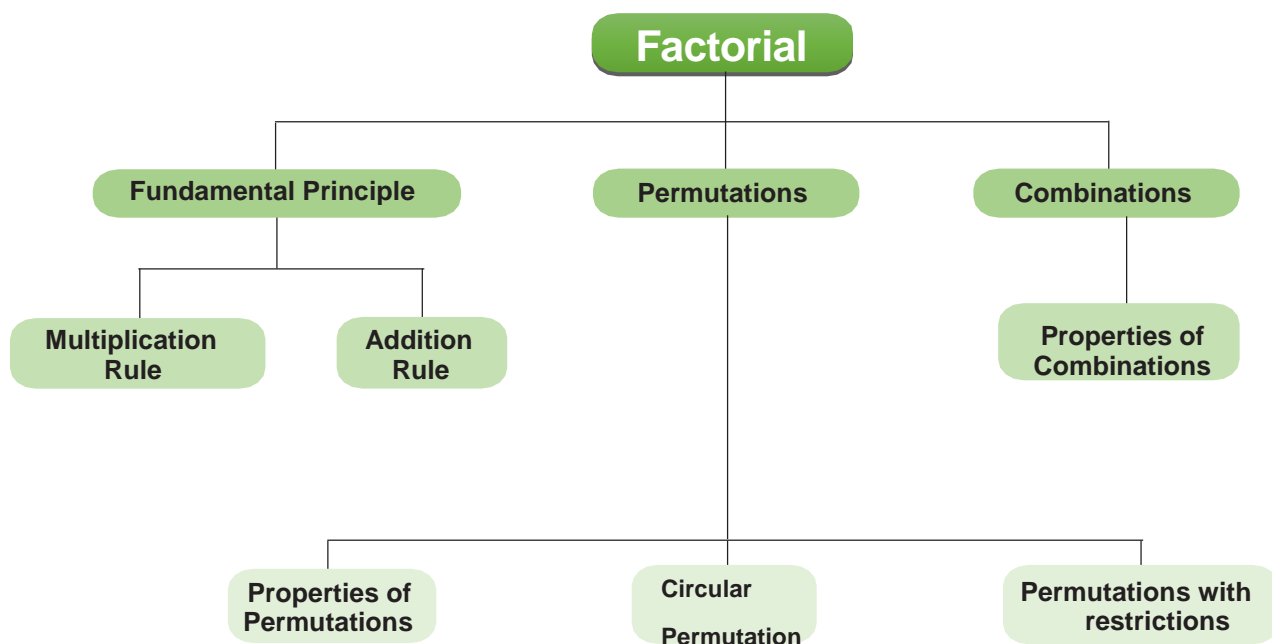

Fundamental principles of counting	Multiplication Rule	If certain thing may be done in ‘m’ different ways and when it has been done, a second thing can be done in ‘n’ different ways then total number of ways of doing both things simultaneously = $m \times n$.
	Addition Rule	If there are two alternative jobs which can be done in ‘m’ ways and in ‘n’ ways respectively the neither of two jobs can be done in $(m+n)$ ways.
Factorial	The factorial n, written as $n!$ or n , represents the product of all integers from 1 to n both inclusive. To make the notation meaningful, when $n=0$, we define $0!$ or $0 = 1$. Thus, $n! = n(n-1)(n-2) \dots \dots \dots 3.2.1$	
Permutations	The ways of arranging or selecting smaller or equal number of persons or objects from a group of persons or collection of objects with due regard being paid to the order of arrangement or selection, are called	

	<p>permutations.</p> <p>The number of permutations of n things chosen r at a time is given by</p> ${}^n P_r = n(n-1)(n-2)\dots(n-r+1)$ <p>Where the product has exactly r factors.</p>
<p>Circular Permutations</p>	<p>(a) n ordinary permutations equal one circular permutation.</p> <p>Hence there are ${}^n P_n / n$ ways in which all the n things can be arranged in a circle. This equals $(n-1)!$.</p> <p>(b) The number of necklaces formed with n beads of different colors</p> <ul style="list-style-type: none"> • Number of permutations of n distinct objects taken r at a time when a particular object is not taken in any arrangement is ${}^{n-1} P_r$. • Number of permutations of r objects out of n distinct objects when a particular object is always included in any arrangement
<p>Combinations</p>	<p>The number of ways in which smaller or equal number of things are arranged or selected from a collection of things where the order of selection or arrangement is not important, are called combinations.</p> ${}^n C_r = n! / r!(n-r)!$ ${}^n C_r = {}^n C_{n-r}$ ${}^n C_0 = n! / \{0!(n-0)!\} = n! / n! = 1.$ ${}^n C_n = n! / \{n!(n-n)!\} = n! / n! \cdot 0! = 1.$ <p>${}^n C_r$ has a meaning only when r and n are integers $0 \leq r \leq n$ and ${}^n C_{n-r}$ has a meaning only when $0 \leq n-r \leq n$.</p> <ul style="list-style-type: none"> • ${}^{n+1} C_r = {}^n C_r + {}^n C_{r-1}$ • $n P_r = n-1 P_r + r n-1 P_{r-1}$
<p>Permutations</p>	<p>Permutations when some of the things are alike, taken all at a time</p> <p>Permutations when each thing may be repeated once, twice, up to r times in any arrangement $= n!$.</p> <p>The total number of ways in which it is possible to form groups by taking some or all of n things $(2^n - 1)$.</p> <p>The total number of ways in which it is possible to make groups by taking some or all out of n ($= n_1 + n_2 + n_3 + \dots$) things, where n_1 things are alike of one kind and so on, is given by</p>

$$\{(n_1 + 1) (n_2 + 1) (n_3 + 1) \dots\} - 1$$

The combinations of selecting r_1 things from a set having n_1 objects and r_2 things from a set having n_2 objects where combination of r_1 things, r_2 things are independent



Question 1

An examination paper consists of 12 questions divided into parts A and B Part A contains 7 questions and part B contains 5 questions. A candidate is required to attempt 8 questions selecting at least 3 from each part. In how many maximum ways can the candidate select the question?

- (a) 35 (b) 175
(c) 210 (d) 420

Answer: d

Explanation:

The candidate can select 8 questions by selecting at last " three from each part in the following ways:

3 questions from part A and 5 questions from part B = $7C_3 \times 5C_5 = 35$ ways

4 questions from part A and part B each

= $7C_4 \times 5C_4 = 175$ Ways.

Questions from part A and 3 questions from part B = $7C_5 \times 5C_3 = 210$ ways

Hence, the total number of ways in which the candidate can select the question will be = $35 + 175 + 210 = 420$ ways

Question 2

Code word is to consist of two English alphabets followed by two distinct numbers between 1 and 9. How many such code words are there?

- (a) 6,15,800 (b) 46,800
(c) 7,19,500 (d) 4,10,800

Answer: b

Explanation:

The number of ways filling the first two places with English alphabets = $26 \times 25 = 650$

The number of ways of filling the last two places with distinct numbers = $9 \times 8 = 72$

The numbers of code words that can be formed are = 650×72

= 46800

Question 3

A boy has 3 library tickets and 8 books of his interest in the library of these 8, he does not want to borrow Mathematics part – II unless Mathematics part – I is also borrowed? In how many ways can he choose the three books to be borrowed?

- (a) 41 (b) 51
(c) 61 (d) 71

Answer: a

Explanation:

There are two cases possible

CASE 1: When Mathematics Part – II is borrowed (i.e. it means Mathematics Part – I has also been borrowed

Numbers of ways = $6C_1 = 6$ ways

CASE 2: When Mathematics part – II is not borrowed (i.e. 3 books are to be selected out of 7)

Number of ways = $7C_3 = 35$ Ways

Therefore, total number ways

$35 + 6 = 41$ ways

Question 4

Find 5!, 4! And 6!

- (a) 720 (b) 120
(c) 380 (d) 620

Answer: a

Explanation:

$5! = 5 \times 4 \times 3 \times 2 \times 1 = 120$; $4! = 4 \times 3 \times 2 \times 1 = 24$; $6! = 6 \times 5 \times 4 \times 3 \times 2 \times 1 = 720$

Question 5

Find $\frac{9!}{6!}; \frac{10!}{7!}$

- (a) 630,504 (b) 504,720
(c) 920,630 (d) 121,720

Answer: b

Explanation:

$$\frac{9!}{6!} = \frac{9 \times 8 \times 7 \times 6!}{6!} = \frac{9 \times 8 \times 7}{7!} = \frac{504}{7!}; \frac{10!}{7!} = \frac{10 \times 9 \times 8 \times 7!}{7!} = 720$$

$$10 \times 9 \times 8 = 720$$

Question 6

Find x if $\frac{1}{9!} + \frac{1}{10!} = \frac{x}{11!}$

- (a) 121 (b) 112
(c) 211 (d) 111

Answer: a

Explanation:

We have,

$$\frac{1}{9!} + \frac{1}{10!} = \frac{x}{11!}$$

$$\rightarrow \frac{1}{9!} + \frac{1}{10 \times 9!} = \frac{x}{11 \times 10 \times 9!}$$

$$\rightarrow \frac{1}{9!} \left[1 + \frac{1}{10} \right] = \left(\frac{x}{11 \times 10} \right) \times \frac{1}{9!}$$

$$\rightarrow 1 + \frac{1}{10} = \frac{x}{11 \times 10}$$

$$\rightarrow \frac{11}{10} = \frac{x}{11 \times 10}$$

$$\rightarrow X = 11 \times 11 = 121$$

Question 7

Evaluate each of $5P_3$, $10P_2$, $11P_5$

- (a) 540 (b) 55440
(c) 5440 (d) 5540

Answer: b

Explanation:

$$5P_3 = 5 \times 4 \times (5-3+1) = 5 \times 4 \times 3 = 60.$$

$$10P_2 = 10 \times \dots \times (10-2+1) = 10 \times 9 = 90$$

$$11P_5 = \frac{11!}{(11-5)!} = 11 \times 10 \times 9 \times 8 \times 7 \times \frac{6!}{6!} = 11 \times 10 \times 9 \times 8 \times 7 = 55440$$

Question 8

How many three letters words can be formed using the letters of the word SQUARE?

- (a) 110 (b) 12
(c) 120 (d) 210

Answer: c

Explanation:

Since the word 'SQUARE' consists of 6 different letters, the number of permutations of choosing 3 letters out of six equals $6P_3 = 6 \times 5 \times 4 = 120$

Question 9

In how many different ways can five persons stand a line for a group photograph?

- (a) 110 ways (b) 120 ways
(c) 130 ways (d) 20 ways

Answer: b

Explanation:

Here we know that the order is important, hence this is the number of permutation of five things taken all at a time. Therefore, this equals

$$5P_5 = 5! = 5 \times 4 \times 3 \times 2 \times 1 = 120 \text{ ways.}$$

Question 10

How many three letters words can be formed using the letters the word HEXAGON?

- (a) 110 (b) 12
(c) 120 (d) 210

Answer: d

Explanation:

Since the word 'HEXAGON' contains 7 different letters, the number of permutations is $7P_3 = 7 \times 6 \times 5 = 210$.

Question 11

First, second and third are to be awarded at an engineering fair in which 13 exhibits have been entered. In how many different?

- (a) 1110 ways (b) 1320 ways
(c) 1830 ways (d) 1716 ways

Answer: d

Explanation:

Here, order of selection is important and repetitions are not meaningful as no exhibit can receive more than one prize. Hence the answer is the number of permutations of 13 things taken three at a time. Therefore, we find ${}_{13}P_3 = \frac{13!}{10!} = 13 \times 12 \times 11 = 1,716$ ways

Question 12

In how many different ways can 3 students be associated with 4 chartered accountants, assuming that each chartered accountant can take at most one student?

- (a) 10 (b) 12
(c) 20 (d) 24

Answer: d

Explanation:

This equals the number of permutations of choosing 3 persons out of 4, hence the answer is ${}_{4}P_3 = 4 \times 3 \times 2 = 24$.

Question 13

Compute the sum of 4 digit numbers which can be formed with the four digits 1, 3, 5, 7, if each digit is used only once in each arrangement.

- (a) 1,06,656 (b) 1,46,800
(c) 7,19,500 (d) 4,10,800

Answer: a

Explanation:

The number of arrangement of 4 different digits taken 4 at a time is given by ${}_{4}P_4 = 4! = 24$. All the four digits will occur equal number of times at each of the positions, namely ones, tens, hundreds, thousands.

Thus, each digit will occur $\frac{24}{4} = 6$ times in each of the positions. The sum of digits in one's position will be $6 \times (1+3+5+7) = 96$. Similar is the case in ten's, hundred's and thousand's places. Therefore, the sum will be $96 + 96 \times 100 + 96 \times 1000 = 106,656$.

Question 14

In how many different ways can a club with 10 members select a President, Secretary and Treasurer, if no member can hold two offices and each member is eligible for any office?

- (a) 720 (b) 780
(c) 960 (d) 630

Answer: a

Explanation:

The answer is the number of permutations of 10 persons chosen three at a time. Therefore, it is ${}_{10}P_3 = 10 \times 9 \times 8 = 720$

Question 15

When jiana arrives in New York, she has eight shops to see, but he has time only to visit six of them. In how many different ways can he arrange her schedule in New York?

- (a) 20,160 (b) 2016
(c) 26105 (d) 21560

Answer: a

Explanation:

She can arrange his schedule in $8P_6 = 8 \times 7 \times 6 \times 5 \times 4 \times 3 = 20,160$ ways

Question 16

When Dr. Ramanujan arrives in his dispensary, he finds 12 patients waiting to see him. If he can see only one patient at a time. Find the number of ways; he can schedule his patients if they all want their turn.

(a) 479001600

(b) 79833600

(c) 34879012

(d) 67800983

Answer: b

Explanation:

There are $12-3 = 9$ patients. They can be seen $12P_9 = 79,833,600$ ways.

Question 17

How many arrangements can be made out of the letters of the word 'DRAUGHT' the vowels never beings separated?

(a) 1440

(b) 720

(c) 740

(d) 750

Answer: a

Explanation:

The word 'DRAUGHT' consists of 7 letters of which 5 are consonants and two are vowels. In the arrangement we are to take all the 7 letters but the restriction is that the two vowels should not be separated.

We can view the two vowels as one letter. The two vowels A and U in this one letter can be arranged in $2! = 2$ ways. (i) AU or (ii) UA. Further, we can arrange the six letters: 5 consonants and one letter consisting of two vowels. The total number of ways of arranging them is $6P_6 = 6! = 720$ ways.

Hence, by the fundamental principle, the total number of arrangements of the letters of the word DRAUGHT, the vowels never being separated = $2 \times 720 = 1440$ ways.

Question 18

An examination paper with 10 questions consists of 6 questions in mathematics and 4 questions in statistic part. At least one question from each part is to be attempted in how many ways can this be done?

(a) 1024

(b) 945

(c) 1000

(d) 1022

Answer: b

Explanation:

Total question = 10

No. of Mathematics questions = 6 No. of statics questions = 4.

No. of ways at least one question of Mathematics

= $(2^6 - 1) = (64 - 1) = 63$

No. of ways at least one question of statics

= $(2^4 - 1) = (16 - 1) = 15$

Total no. of ways = $63 \times 15 = 945$

Questions 19

A student has three books on computer, three books on Economics and five books on Commerce. If these books are to be arranged subject wise, then these can be placed on a shelf in the number of ways:

- (a) 25290 (b) 25092
(c) 4320 (d) 25920

Answer: d

Explanation:

$$\begin{aligned} \text{No. of ways} &= 3! 3! 5! 3! \\ &= 6 \times 6 \times 120 \times 6 \\ &= 216 \times 120 \\ &= 25,920 \end{aligned}$$

Questions 20

A person has ten friends of whom six are relatives. If h invites five guests 'SUCH' that three are his relatives, then the total number of ways in which he can invite then are:

- (a) 30 (b) 60
(c) 120 (d) 75

Answer: c

Explanation:

Total friend: 10

No. of Relative = 6

No. of friend = 4

No. of ways to invite five guests such that three of them are his relatives.

$$\begin{aligned} &= {}^6C_3 \times {}^4C_2 \\ &= \frac{6!}{3! \times 3!} \times \frac{4!}{2! \times 2!} \\ 20 \times 6 &= 120 \end{aligned}$$

Questions 24

Six seats of articulated clerks are vacant in a 'Chartered Accountant Firm'.

How many different batches of candidates can be chosen out of ten candidates?

- (a) 216 (b) 210
(c) 220 (d) 230

Answer: b

Explanation:

The number of ways in which 6 articulated clerks can be selected out of 10 candidates

$$= {}^{10}C_6 = 210 \text{ ways.}$$

Question 25

Six persons A, B, C, D, E and F are to be seated at a circular table. In how many ways can this be done, if A must always has either B or C on his right and B must always have either C or D on his right?

- (a) 3 (b) 6
(c) 12 (d) 18

Answer: d

Explanation:

Using the given restrictions, we must have AB or AC and AB or BD

Therefore, we have the following alternatives

ABC, D, E, F, which gives $(4 - 1)!$ Or $3!$ Ways.

ABC, D, E, F which gives $(4 - 1)!$ Or $3!$ Ways.

AC, BD, E, F, which gives $(4 - 1)$ or $3!$ Ways.

Hence, the total number of ways are

$$= 3! + 3! + 3!$$

$$= 6 + 6 + 6 = 18 \text{ ways}$$

Question 26

A fundamental principle of counting is:

(a) $m \times n, m - n$

(b) $m \times n, m + n$

(c) $m + n, m \div n$

(d) $m \div n, m - n$

Answer: b

Explanation:

Fundamental principles of counting

a. Multiplications Rule: $m \times n$

b. Addition Rule: $m + n$

Question 27

If $n_{C_r} = n_{C_{r-1}}$ and n_{P_r} and $n_{P_{r+1}}$, then the value of n is 27.

(a) 3

(b) 4

(c) 2

(d) 5

Answer: a

Explanation:

The conditions provided that $n - r = r - 1$ or $r = \frac{n+1}{2}$ so if

We put $n = 3$, then $r = 2$ satisfies the conditions

Question 28

$n_{P_r} \div n_{C_r} =$

(a) $n!$

(b) $(n - r)!$

(c) 48

(d) $r!$

Answer: d

Explanation:

Question 29

The number of ordered triplets of positive integers which are solutions of the equation

$x+y+z = 100$ is

(a) 6005

(b) 4851

(c) 5081

(d) none of these

Answer: b

Explanation:

The number of triplets of positive integers which are solutions of

$X + y + z = 100 =$ coefficient of x^{100} in $(x + x^2 + x^3 + \dots)^3$

$=$ coefficient of x^{100} in $x^3(1 - x)^{-3} =$ coefficient of x^{100} in

$X^3 (1 + 3x + 6x^2 + \dots + \frac{(n+1)(n+2)}{2}x^n + \dots)$

$$= \frac{(97+1)(97+2)}{2} = 49 \times 99 = 4851$$

Question 30

The number of way to sit 3 men and 2 women in a bus such that total number of sitted men and women on each side is 3

- (a) $5!$ (b) $6_{C_5} \times 5!$
 (c) $6! \times 6_{P_5}$ (d) $5! + 6_{C_5}$

Answer: b

Explanation:

3 men and 2 women equal to 5. A group of 5 members make $5!$ Permutations with each other. The number of ways to sit 5 members = $5!$ 6 places are filled by 5 members by 6_{C_5} ways. The total number of ways to sit 5 members on 6 seats of a bus = $6_{C_5} \times 5!$

Question 31

If $P(n, r) = 1680$ and $C(n, r) = 70$, then $69n + r! =$

- (a) 128 (b) 576
 (c) 256 (d) 625

Answer: b

Explanation:

$$P(n, r) = 1680 \frac{n!}{(n-r)!} = 1680? \dots \text{ (i) } C(n, r) = 70$$

$$\frac{n!}{r!(n-r)!} = 70? \text{ (ii) } \frac{1680}{r!} = 70. \text{ [From (i) and (ii)]}$$

$$r! = \frac{1680}{70} = 24 \rho r = 4 \therefore P(n, 4) = 1680 \therefore$$

$$n(n-1)(n-2)(n-3) = 1680 \rho n = 8 \therefore$$

$$8 \times 7 \times 6 \times 5 = 1680 + r! = 69 \times 8 + 4! = 552 + 24 = 576$$

Question 32

Number of divisors of $n = 38808$ except 1 and n is

- (a) 70 (b) 68
 (c) 72 (d) 74

Answer: a

Explanation:

$$\text{Since } 38808 = 8 \times 4851$$

$$8 \times 9 \times 539 = 8 \times 9 \times 7 \times 7 \times 11 = 2^3 \times 3^2 \times 7^2 \times 11$$

Number of divisors = $(3 + 1)(2 + 1)(2 + 1)(1 + 1) = 72$. This includes two divisors 1 and 38808. Hence the required number off divisors = $72 - 2 = 70$

Question 33

If eleven members of a committee sit at a round table so that the president and secretary always sit together, then the number of arrangement is

- (a) $10! \times 2$ (b) $10!$
 (c) $9! \times 2$ (d) None of these

Answer: c

Explanation:

Required number of ways $9! \times 2$ (by fundamental property of Circular permutation).

Question 34

In how many ways can 5 keys be put in a ring?

- (a) $\frac{1}{2} 4!$ (b) $\frac{1}{2} 5!$
 (c) $4!$ (d) $5!$

Answer: a

Explanation:

Mark the keys as 1, 2, 3, 4, 5

Assume the ring as a circle with 5 positions.

First position can be taken by any one of them.

The 2nd positions has 4 possibility, 3rd has 3, 4th has 2, 5th has 1

Totally $4 \times 3 \times 2 \times 1 = 24$.

Question 35

A question paper is divided into two parts A and B and each part contains 5 questions. The number of ways in which a candidate can answer 6 questions selecting at least two questions from each part is

- (a) 80
- (b) 810
- (c) 200
- (d) None of these

Answer: c

Explanation:

The number of ways that the candidate may select 2 questions from A and 4 from B = $5C_2 \times 5C_4$
 4 questions from A and 2 from B = $5C_4 \times 5C_2$. Hence total numbers of ways are 200.

Question 36

How many number lying between 10 and 1000 can be formed from the digits 1, 2, 3, 4, 5, 6, 7, 8, 9 (repetition is allowed)

- (a) 1024
- (b) 810
- (c) 2346
- (d) None of these

Answer: b

Explanation:

The total number between 10 and 1000 are 989 but we have to form the numbers by using numerals 1, 2,.....9, i.e. 0 is not occurring so the numbers containing any 0? would be excluded i.e., Required number of ways

$$= 989 - \left\{ \begin{array}{l} 20, 30, 40, \dots \dots \dots 100 = 9 \\ 101, 102, \dots \dots \dots 300 = 19 \\ 201, \dots \dots \dots 300 = 19 \\ \dots \dots \dots \\ \dots \dots \dots \\ 901, \dots \dots \dots 990 = 18 \end{array} \right\}$$

= $989 - (9 + 18 + 19 \times 8) = 810$. Alter: Between 10 and 1000, the numbers are of 2 digits And 3 digits. Since repetition is allowed, so each digit can be filled in 9 ways. Therefore number of 2 digit numbers = $9 \times 9 = 81$ and number of 3 digit numbers $9 \times 9 \times 9 = 729$. Hence total ways = $81 + 729 = 810$

Question 37

The number of ways in which the letters of the word TRIANGLE can be arranged such that two vowels do not occur together is

- (a) 1200
- (b) 2400
- (c) 14400
- (d) None of these

Answer: c

Explanation:

T.R.N.G.L Three vowels can be arrange at 6 places in $6P_3 = 120$ ways. Hence the required number of arrangements = $120 \times 5! = 14400$

Question 38

There are four balls of different colours and four boxes of colours same as those of the balls. The number of ways in which the balls one in each box, could be such that a ball does not go to box of its own colour is

- (a) 8 (b) 7
(c) 9 (d) None of these

Answer: c**Explanation:**

Since the number of derangements in such a problems is given by

$$n! \left\{ 1 - \frac{1}{1!} + \frac{1}{2!} - \frac{1}{3!} + \frac{1}{4!} \dots \dots \dots (-1)^n \frac{1}{n!} \right\}$$

$$\therefore \text{Number of derangements are} = 4! \left\{ \frac{1}{2!} - \frac{1}{3!} + \frac{1}{4!} \right\}$$

$$= 12 - 4 + 1 = 9$$

Question 39

If $56P_{r+6} : 54P_{r+3} = 30800 : 1$, then $r =$

- (a) 31 (b) 41
(c) 51 (d) none of these

Answer: b**Explanation:**

$$\frac{56!}{(50-r)!} \times \frac{(51-r)!}{54!}$$

$$\frac{30800}{1} = 56 \times 55 \times (51-r) = 30800$$

$$r = 41$$

Question 40

The number of ways of dividing 52 cards amongst four players so that three players have 17 cards each and the fourth player just one card, is

- (a) $\frac{52!}{(17!)^3}$ (b) $\frac{52!}{(17!)^2}$
(c) 52! (d) none

Answer: a**Explanation:**

For the first set number of ways $52C_{17}$. Now out of 35 cards left 17 cards can be put for second in $35C_{17}$ ways similarly for 3rd in $18C_{17}$. One card for the last set can be put in only one way.

Therefore the required number of ways for the proper distribution = $\frac{52!}{35!17!} \times \frac{35!}{18!17!} \times \frac{18!}{17!1!} \times$

$$1! = \frac{52!}{(17!)^3}$$

Question 41

m men and n women are to be seated in a row so that no two women sit together. If $m > n$, then then the number of ways in which can be seated is

- (a) $\frac{m!(m+1)!}{(m-n+1)!}$ (b) $\frac{m!(m-1)!}{(m-n+1)!}$
(c) $\frac{(m-1)!(m+1)!}{(m-n+1)!}$ (d) none

Answer: a**Explanation:**

First arrange m men, in a row in $m!$ Ways. Since $n < m$ and no two women can sit together, in any one of the $m!$ Arrangement, there are places in which n women can be arranged in $m + 1P_n$

$$= \frac{m!(m+1)!}{[(m+1)-n)!} = \frac{m!(m+1)!}{(m-n+1)!}$$
Question 42

The number of times the digit 3 will be written when listing the integers from 1 to 1000 is:

- (a) 369 (b) 300
(c) 271 (d) 302

Answer: b**Explanation:**

To find number of times 3 occurs in listing the integer from 1 to 999. (Since 3 does not occur in 1000). Any number between 1 to 999 is a 3 digit number xyz where the digit x, y, z are any digits from 0 to 9. Now, we first count the numbers in which 3 occurs once only. Since 3 can occur at one place in $3C_1$ ways. There are $3C_1 \cdot (9 \times 9) + 3 \times 1 = 300$

Question 43

Ten persons, amongst whom are A, B, and c to speak at a function. The number of ways in which it can be done. If A wants to speak before B and B wants to speak before C is

- (a) $\frac{10!}{6}$ (b) $\frac{3!}{7!}$
(c) $10P_3 \cdot 7!$ (d) None of these

Answer: a**Explanation:**

For A, B, C, to speak in order of alphabets 3 places out of 10 may be chosen first in 1. $3C_2 = 3$ ways. The remaining 7 persons can speak in $7!$ Ways. Hence, the number of ways in which all the 10 person can speak is $10C_3 \cdot 7! = \frac{10!}{3!} = \frac{10!}{6}$

Question 44

How many words can be made out from the letters of the word INDEPENDENCE, in which vowels always come together?

- (a) 16800 (b) 16630
(c) 1663200 (d) None of these

Answer: a**Explanation:**

Required numbers of ways are $\frac{8!}{2!3!} \times \frac{5!}{4!} = 16800$. {Since IEEEEENDPNDNC = 8 letters}.

Question 45

The exponent of 3 in 100! Is

- (a) 33 (b) 44
(c) 48 (d) 52

Answer: c**Explanation:**

Let $E(n)$ denote the exponent of 3 in n . the greatest integer less than 100 divisible by 3 is 99. We have

$$E(100!) = E(1 \cdot 2 \cdot 3 \cdot 4 \dots 99 \cdot 100)$$

$= E(3 \cdot 6 \cdot 9 \dots 99)$
 $= E[(3 \cdot 1)(3 \cdot 2)(3 \cdot 3) \dots (3 \cdot 33)]$
 $= 33 + E(1 \cdot 2 \cdot 3 \dots 33)$ Now
 $E(1 \cdot 2 \cdot 3 \dots 33) = E(3 \cdot 6 \cdot 9 \dots 33)$
 $= E[(3 \cdot 1)(3 \cdot 2)(3 \cdot 3) \dots (3 \cdot 11)]$
 $= 11 + E(1 \cdot 2 \cdot 3 \dots 11)$ And
 $E(1 \cdot 2 \cdot 3 \dots 11) = E[(3 \cdot 1)(3 \cdot 2)(3 \cdot 3)]$
 $3 + E(1 \cdot 2 \cdot 3) = 3 + 1 = 4$ Thus
 $E(100!) = 33 + 11 + 4 = 48$

Question 46

A dictionary is printed consisting of 7 lettered words only that can be made with a letter of the word CRICKET. If the words are printed at the alphabetical order, as in an ordinary dictionary, then the number of word before the word CRICKET is

- (a) 530 (b) 480
(c) 531 (d) 481

Answer: a**Explanation:**

The number of words before the word CRICKET is $4 \times 5! + 2 \times 4! + 2! = 530$

Question 47

The number of positive integral solutions of $abc = 30$ is

- (a) 30 (b) 27
(c) 8 (d) none of these

Answer: b**Explanation:**

We have, $30 = 2 \times 3 \times 5$. So, 2 can be assigned to either a or b or c i.e. 2 can be assigned in 3 ways. Similarly, each of 3 and 5 can be assigned in 3 ways. Thus the no. of solutions is $3 \times 3 \times 3 = 27$.

Question 48

The number of different words that can be formed out of the letters of the word 'MORADABAD' taken four at a time is

- (a) 500 (b) 600
(c) 620 (d) 626

Answer: d**Explanation:**

In MORADABAD, we have 6 different types of letters 3A's, 2D's and rest four different. We have to form words of 4 letters. (i) All letters ${}^6P_4 = 6 \times 5 \times 4 \times 3 = 360$. (ii) Two different two a like ${}^2C_1 \times {}^5C_2 \times \frac{4!}{2!} = 240$ (iii) 3 alike 1 different ${}^1C_1 \times {}^5C_3 \times \frac{4!}{2!} = 20$ (iv) 2 alike of one type and 2 alike of other type ${}^2C_2 \times \frac{4!}{3!} = 6$ Therefore total number of words
 $= 360 + 240 + 20 + 6 = 626$

PREPARE FOR WORST**Question 1**

How many 3 letter words with or without meaning can be formed out of the letters of the word MONDAY when repetition of words is allowed?

- (a) 125 (b) 216
(c) 120 (d) 320

Question 2

In how many ways the letters in the word TOOTH can be arranged?

- (a) 120 (b) 40
(c) 20 (d) 30

Type - 2**Question 1**

How many five letters words with or without meaning, can be formed from the word 'COMPLEXIFY', if repetition of letters is not allowed?

- (a) 43200 (b) 30240
(c) 12032 (d) 36000

Question 2

In how many different ways can the letters of the word 'LOGARITHMS' be arranged so that the vowels always come together?

- (a) 6720 (b) 241920
(c) 40320 (d) 360344

Question 3

How many three digit numbers can be formed from the digits 3, 4, 5, 7, 8, and 9. Also, the number formed should be divisible by 5 and no repetition is allowed?

- (a) 20 (b) 24
(c) 25 (d)

Type 3**Question 1**

An ice cream seller sells 5 different ice-creams. John wants to buy 15 ice creams for his friends. In how many ways can he buy the ice-cream?

- (a) 1450 (b) 3768
(c) 3879 (d) 1540

Question 2

There are 5 types of soda flavor available in a shop. In how many ways can 10 soda flavors be selected?

- (a) 1454 (b) 1001
(c) 1211 (d) 1540

Type - 4**Question 1**

A wooden box contains 2 grey balls, 3 pink balls and 4 green balls. Find out in how many ways 3 balls can be drawn from the wooden box. Make sure that at least one pink ball is included in the draw?

- (a) 64 (b) 46
(c) 56 (d) 65

Question 2

There are 5 boys and 10 girls in a classroom. In how many ways teacher can select 2 boys and 3 girls to make a dance group?

- (a) 720 (b) 1200
(c) 240 (d) 840

Question 3

There are 10 consonants and 5 vowels. Out of which how many words of 5 consonants and 2 vowels can be made?

- (a) 2520 (b) 1200
(c) 210 (d) 720

Question 4

A committee of 5 persons is to be formed from 6 men and 4 women. In how many ways can this be done when at least 2 women are included?

- (a) 196 (b) 186
(c) 190 (d) 200

Question 5

If the letters of the word SACHIN are arranged in all possible ways and these words are written out as in dictionary, then the word 'SACHIN' appears at serial number:

- (a) 601 (b) 600
(c) 603 (d) 602

Question 6

A college has 10 basketball players. A 5-member team and a captain will be selected out of these 10 players. How many different selections can be made?

- (a) 1260 (b) 1400
(c) 1250 (d) 1600

Question 7

When four fair dice are rolled simultaneously, in how many outcomes will at least one of the dice show 3?

- (a) 620 (b) 671
(c) 625 (d) 567

Question 8

A letter lock consists of three rings each marked with six different letters. The number of distinct unsuccessful attempts to open the lock is at the most?

- (a) 215 (b) 268
(c) 254 (d) 216

Question 9

In how many ways can the letters of the word EDUCATION be rearranged so that the relative position of the vowels and consonants remain the same as in the word EDUCATION?

- (a) $4! \times 4!$ (b) $5! \times 5!$
(c) $4! \times 5!$ (d) $3! \times 4!$

Question 10

In a Plane there are 37 straight lines, of which 13 pass through the point A and 11 pass through the point B. Besides, no three lines pass through one point, no lines passes through both points A and B , and no two are parallel. Find the number of points of intersection of the straight lines.

- (a) 525 (b) 535
(c) 545 (d) 555

Question 11

How many different four letter words can be formed (the words need not be meaningful using the letters of the word "MEDITERRANEAN" such that the first letter is E and the last letter is R?

- (a) 59 (b) 56
(c) 64 (d) 55

Question 12

In how many ways can 5 different toys be packed in 3 identical boxes such that no box is empty, if any of the boxes may hold all of the toys?

- (a) 36 (b) 25
(c) 24 (d) 72

Question 13

In a box, there are 5 black pens, 3 white pens and 4 red pens. In how many ways can 2 black pens, 2 white pens and 2 red pens can be chosen?

- (a) 180 (b) 220
(c) 240 (d) 160

ANSWERS AVAILABLE ON:

- TELEGRAM CHANNEL: t.me/KINSHUKInstitute
- WEBSITE : WWW.KITest.IN
- KITest APP

PAST EXAMINATION QUESTIONS:

MAY 2018

Question 1

The number of triangle that can be formed by choosing the vertices from a set of 12 points, seven of which lie on the same straight line, is:

- (a) 185 (b) 175
(c) 115 (d) 105

Answer: a

Explanation:

Here $n = 12$, $k = 7$

No. of triangle are formed from 'n' point

In which (k) points are collinear = $nC_3 - kC_3$

$$\begin{aligned}
 &= 12C_3 - 7C_3 \\
 &= \frac{12 \times 11 \times 10}{3 \times 2 \times 1} - \frac{7 \times 6 \times 5}{3 \times 2 \times 1} \\
 &= 220 - 35 \\
 &= 185
 \end{aligned}$$

Question 2

If $1000C_{98} - 999C_{97} + xC_{901}$, find x:

- (a) 999 (b) 998
(c) 997 (d) 1000

Answer: a

Explanation:

$$\text{If } 1000C_{98} - 999C_{97} + xC_{901}$$

$$\therefore nC_r + nC_{r-1} = n + 1C_r$$

$$\text{Then } x = 999[999C_{901} + 999C_{98}]$$

NOV 2018**Question 1**

A bag contains 4 red, 3 black, and 2 white balls. In how many ways 3 balls can be drawn from his bag so that they include at least one black ball?

- (a) 64 (b) 46
(c) 85 (d) None

Answer: a

Explanation:

No. of total balls = 4 Red + 3 Black + 2 white = 9 balls

Total number of ways

$$= 3C_3 + (3C_2 \times 6C_1) + (3C_1 \times 6C_2) \text{ [because 6 are non black]}$$

$$= 1 + [3 \times 6] + [3 \times (6 \times 5 \times 2 \times 1)] = 1 + 18 + 45 = 64$$

Question 2

The number of words from the letter word BHARAT, in which B and H will never come together, is

- (a) 360 (b) 240
(c) 120 (d) None

Answer: b

Explanation:

Given word

'B H A R A T'

1 2 3 4 5 6

$$\text{Total No. of ways arrange the letter word} = \frac{6!}{2!} = \frac{720}{2} = 360$$

If Letter 'B' and 'H' are never taken together

$$= 360 - 120$$

$$= 240$$

Question 3

The value of N in $= \frac{1}{7!} + \frac{1}{8!} + \frac{N}{9!}$ is

- (a) 81 (b) 78
(c) 89 (d) 64

Answer: a

Explanation:

$$\begin{aligned} \text{If } \frac{1}{7!} + \frac{1}{8!} &= \frac{N}{9!} \\ \frac{9 \times 8 \times 1}{9 \times 8 \times 7!} + \frac{9 \times 1}{9 \times 8!} &= \frac{N}{9!} \\ \frac{9!}{72 \times 9} + \frac{N}{9!} &= \frac{N}{9!} \\ \frac{9!}{72} + \frac{N}{9!} &= \frac{N}{9!} \\ \frac{9!}{72} &= \frac{N}{9!} \\ N &= 81 \end{aligned}$$

Question 4

If $n_{P_r} = 720$, $n_{P_r} = 120$, then r is

- (a) 3 (b) 4
(c) 5 (d) 6

Answer: a

Explanation:

Given $n_{P_r} = 720$, $n_{C_r} = 120$

We know that

$$\begin{aligned} \frac{n_{C_r}}{n_{C_r}} &= \frac{1}{r} \\ \frac{120}{720} &= \frac{1}{r} \\ \frac{1}{6} &= \frac{1}{r} \\ R &= 3 \end{aligned}$$

MAY 2019

Question 1

If $11C_x = 11C_{2x-4}$ and $x \neq 4$ then the value of $7C_x =$

- (a) 20 (b) 21
(c) 22 (d) 23

Answer: b

Explanation:

Equate bases of LHS and RHS

So $x=4$

Therefore, LHS = RHS

$$11-x = 2x-4$$

$$x=5$$

$$7C_3 = 7C_2 = 21$$

Question 2

Which of the following is not a correct statement?

- (a) $n_{P_n} = n_{P_{n-1}}$ (b) $n_{P_n} = 2 \cdot n_{P_{n-2}}$

(c) $n_{P_n} = 3 \cdot n_{P_{n-3}}$

(d) $n_{P_n} = n \cdot n \cdot (n-1)_{P_{n-1}}$

Answer: d**Explanation:**LHS \neq RHS

In case of d option

Question 3**How many words can be formed with the letter of the word "PARALLEL". So that all L's do not come together?**

(a) 2000

(b) 3000

(c) 4000

(d) None of these

Answer: b**Explanation:**

There are $8!$ ways of arranging the eight letters of "PARALLEL", but since there are three "L"s and two "A"s, we must divide through by $3! \times 2!$ to get a total of $\frac{8!}{3! \times 2!}$ permutations.

Okay, so how many of these have all three "L"s together?

$$\frac{8!}{3! \times 2!} - 6 \times \frac{5!}{2!} = 3000$$

Question 4**The Indian cricket team consists of 16 players. It includes 2 wicket keepers and 5 bowlers. In how many ways can a cricket eleven be selected if we have to select 1 wicket keeper and at least 4 bowlers?**

(a) 1024

(b) 1900

(c) 2000

(d) 1092

Answer: d**Explanation:**

We are to choose 11 players including 1 wicket keeper and 4 bowlers or, 1 wicket keeper and 5 bowlers.

Number of ways of selecting 1 wicket keeper, 4 bowlers and 6 other player's in

$${}^2C_1 \times {}^5C_4 \times {}^9C_6 = 840$$

Number of ways of selecting 1 wicket keeper, 5 bowlers and 5 other players in ${}^2C_1 \times {}^5C_4 \times {}^9C_5 = 252$

Total number of ways of selecting the team = $840 + 252 = 1092$.

NOV 2019**Question 1****Three girls and five boys are to be seated in a row so that no two girls sit together. Total no. of ways of this arrangement are:**

(a) 14,400

(b) 120

(c) $5P_3$

(d) $3! \times 5!$

Answer: a**Explanation:**

(a) Required arrangement

X B₁ X B₂ X B₃ X B₄ X B₅ X

No. of ways of arranging 3 girls in 6 places

$$= {}^6P_3$$

$$\begin{aligned} \text{Total ways} &= {}^6P_3 \times {}^5P_5 \\ &= \frac{6!}{(6-3)!} \times 5! \\ &= \frac{6 \times 5 \times 4 \times 3!}{3!} \times 120 = \text{Rs. } 14,400 \end{aligned}$$

Question 2

How many numbers can be formed with the help of 2, 3, 4, 5, 6, 1 which is not divisible by 5, given that it is a five-digit no. and not repeating?

- (a) 600 (b) 400
(c) 1200 (d) 1400

Answer: a

Explanation:

(a) No's 2, 3, 4, 5, 6, 1.

A no. is divisible by 5 when it ends with 0 or 5

T T H T H H O

— — — — —

No. of ways of filling one's digit = 5 (all except 5)

No. of ways of filling ten's digit = 5

No. of ways of filling thousand place = 4

No. of ways of filling ten thousand place = 3

No. of ways of filling hundred's place = 2

$$\begin{aligned} \text{Total ways} &= 5 \times 5 \times 4 \times 3 \times 2 \\ &= 600 \text{ ways} \end{aligned}$$

Question 3

How many different groups of 3 people can be formed from a group of 5 people?

- (a) 5 (b) 6
(c) 10 (d) 9

Answer: c

Explanation:

(c) We know,

No. of ways to choose r objects out of n objects is nC_r

Using the formula,

Choosing 3 distinct objects (groups) from

$$5 = {}^5C_3 = \frac{5!}{(5-3)! \times 3!}$$

$$= \frac{5!}{2! \times 3!}$$

$$= \frac{5 \times 4 \times 3!}{2 \times 3!}$$

$$= 10 \text{ ways}$$

Question 4

In how many ways can 4 people be selected at random from 6 boys and 4 girls if there are exactly 2 girls?

- (a) 90 (b) 360
(c) 92 (d) 480

Answer: a

Explanation

(a) Boys (6) Girls (4)

2 2

No. of ways of selecting 2 boys out of 6 = 6C_2

No. of ways of selecting 2 girls out of 4 = 4C_2

Total ways = ${}^6C_2 \times {}^4C_2$

$$= \frac{6!}{(6-2)! \times 2!} \times \frac{4!}{2! \times (4-2)!}$$

$$= \frac{6 \times 5 \times 4!}{4! \times 2} \times \frac{4 \times 3 \times 2!}{2! \times 2}$$

$$= 15 \times 6 = 90 \text{ ways.}$$

Question 5

${}^n P_3 : {}^n P_2 = 2 : 1$

(a) 4

(b) 7/2

(c) 5

(d) 2/7

Answer: a

Explanation:

$$(a) {}^n P_r = \frac{n!}{(n-r)!}$$

$${}^n P_3 : {}^n P_2 = 2 : 1$$

$$\frac{n!}{(n-3)!} : \frac{n!}{(n-2)!} = \frac{2}{1}$$

$$\frac{n!}{(n-3)!} \times \frac{(n-2)!}{n!} = \frac{2}{1}$$

DEC 2020

Question 15

If $n P_4 = 20 n P_2 =$ where P denotes the number of permutations n = _____

(a) 4

(b) 2

(c) 5

(d) 7

Answer: d

Explanation:

$$n P_r = \frac{n!}{(n-r)!}$$

Here,

$$n P_4 = 20 n P_2$$

$$= \frac{n!}{(n-4)!} = 20 = \frac{n!}{(n-2)!}$$

$$(n-2)! = 20(n-4)!$$

$$(n-2)(n-3)(n-4)! = 20(n-4)!$$

$$(n-2)(n-3) = 20$$

$$n^2 - 5n + 6 = 20$$

$$n^2 - 5n - 14 = 0$$

$$n^2 - 7n + 2n - 14 = 0$$

$$n(n-7) + 2(n-7) = 0$$

$$(n+2)(n-7) = 0$$

$$\text{If } n+2 = 0 \Rightarrow n = -2 \text{ (Not possible)}$$

$$\text{If } n-7 = 0 \Rightarrow n = 7$$

Thus, the value of n is 7.

Question 16

A fruit basket contains 7 apples, 6 bananas and 4 mangoes. How many selections of 3 fruits can be made so that all 3 are apples?

- (a) 120 ways (b) 35 ways
(c) 168 ways (d) 70 ways

Answer: b

Explanation:

Given:

Number of Bananas = 6

Number of Apples = 7

Number of Mangoes = 4

To find: Number of ways can a person make a selection of fruits from the basket.

Number of ways to select zero or more bananas = $6 + 1 = 7$ ways

Number of ways to select zero or more apples = $7 + 1 = 8$ ways

Number of ways to select zero or more mangoes in $4 + 1 = 5$ ways

So, Total number of ways = $5 \times 8 \times 7 = 280$

We included a case of 0 Banana, 0 apple and 0 mangoes, so we have to subtract this from total number of ways,

\Rightarrow Number of ways = $280 - 1 = 279$ ways

Therefore, A person can make a selection of fruits from the basket is 279 ways.

\therefore 3 fruits can be made so that all 3 are apples is 35

Question 17

Out of 7 boys and 4 girls a team of a debate club of 5 is to be chosen. The number of teams such that each team includes at least one girl is__

- (a) 429 (b) 439
(c) 419 (d) 441

Answer: d

Explanation:

The Team Consist of 4 girls +1 boy

Number of selections $4C_3 \times 7C_1 = 1 \times 7 = 7$

Hence, the total number of teams that can be formed = $140+210+84+7= 441$

Question 18

From a group of 8 men and 4 women, 4 persons are to be selected to form a committee so that at least 2 women are there on the committee. In how many ways can it be done?

- (a) 201 (b) 168
(c) 202 (d) 220

Answer: a

Explanation:

Total number of men = 8

Total number of women = 4

Committee = 4 persons \rightarrow at least 2 women

Case 1 \rightarrow 2 Women + 2 men $\rightarrow 4C_2 \times 8C_2 = 168$

Case 2 \rightarrow 3 women + 1 men $\rightarrow 4C_3 \times 8C_1 = 32$

Case 3 \rightarrow 4 women + 0 men $\rightarrow 4C_4 = 1$

Total 201

IAN 2021

Question 1

Eight chairs are numbered from 1 to 8. Two women and three men are to be seated by allowing one chair for each. First, the women choose the chairs from the chairs numbered 1 to 4 and then men select the chairs from the remaining. The number of possible arrangements is:

- (a) 120 (b) 288
(c) 32 (d) 1440

Answer: d

Explanation:

1440

Step-by-step explanation:

First women can take any of the chairs marked 1 to 4 in 4 different way.

Second women can take any of the remaining 3 chairs from those marked 1 to 4 in 3 different ways.

So, total no of ways in which women can take seat = 4×3

$\Rightarrow 4P_2$

$4P_2 = 4!(4-2)!$

$= 4 \times 3 \times 2 \times 1 \times 2 \times 1 = 12$

After two women are seated 6 chairs remains

First man take seat in any of the 6 chairs in 6 different ways, second man can take seat in any of the remaining 5 chairs in 5 different ways

Third man can take seat in any of the remaining 4 chairs in 4 different ways.

So, total no of ways in which men can take seat = $6 \times 5 \times 4$

$\Rightarrow 6P_3$

$6P_3 = 6!(6-3)!$

$\Rightarrow 6 \times 5 \times 4 \times 3 \times 2 \times 1 \times 3 \times 2 \times 1$

$\Rightarrow 120$

Hence total number of ways in which men and women can be seated = 120×12

$\Rightarrow 1440$

Question 2

'n' locks and 'n' corresponding keys are available but the actual combination is not known. The maximum number of trials that are needed to assigns the keys to the corresponding locks is.

- (a) $(n-1) C_2$ (b) $(n+1) C_2$
(c) $\sum_{k=2}^n (k-1)$ (d) $\sum_{k=2}^n K$

Answer: d

Question 3

The harmonic mean of the roots of the equation

$(5 + \sqrt{2})x^2 - (4 + \sqrt{5})x + 8 + 2\sqrt{5} = 0$, is

- (a) 2 (b) 4
(c) 6 (d) 8

Answer: b

Explanation:

let the 2 roots be α, β

$$\text{H.M.} = \frac{2\alpha\beta}{\alpha+\beta} = \frac{2 \times \frac{8+2\sqrt{5}}{5+\sqrt{2}}}{\frac{4+\sqrt{5}}{6+\sqrt{2}}} = \frac{2 \times 2 (4+\sqrt{5})}{(4+\sqrt{5})} = 4$$

Question 4

There are ten flights operating between city A and city B. The number of ways in which a person can travel from city A to city B and return by different flight, is

- (a) 90 (b) 95
(c) 80 (d) 78

Answer: a

Explanation:

To go from A to B = 10 Flight
& to go from B to A = 9 flights
(as cannot complaining in some flight)
 $10 \times 9 = 90$ ways

Question 5

How many odd numbers of four digits can be formed with digits 0, 1, 2, 3, 4, 7 and 8?

- (a) 150 (b) 180
(c) 120 (d) 210

NOTE: The correct Ans is: 300

Answer: b

Explanation:

$5 \times 5 \times 4 \times 3 = 300$
(0 cannot be here & 1 used in last cannot be here)
(1,3,7) can be on last place as it should be odd

Question 6

In how many different ways, can the letters of the word 'DETAIL' be arranged in such a way that the vowels occupy only the odd numbered position?

- (a) 32 (b) 36
(c) 48 (d) 60

Answer: b

Explanation:

Since detail has 6 letters, there are 3 odd positions, the 1st, 3rd, and 5th spots. Let's determine how many ways the word can be arranged when the vowels occupy the odd positions.

1st spot: 3 options (any of the 3 vowels)

2nd spot: 3 options (any of the 3 consonants)

3rd spot: 2 options (any of the 2 remaining vowels)

4th spot: 2 options (any of the 2 remaining consonants)

5th spot: 1 option (the last remaining vowel)

6th spot: 1 option (the last remaining consonant)

So, the word can be arranged in $3 \times 3 \times 2 \times 2 \times 1 \times 1 = 36$ ways.

Question 7

${}^n\text{C}_p + 2{}^n\text{C}_{p-1} + {}^n\text{C}_{p-2}?$

- (a) ${}^{n+1}\text{C}_p$ (b) ${}^{n+2}\text{C}_p$
(c) ${}^{n+1}\text{C}_{p+1}$ (d) ${}^{n+2}\text{C}_{p-1}$

Answer: d

Explanation:

Direct Formula

for refer another origin formula

$${}^n C_r + {}^n C_{r-1} = {}^{n+1} C_r$$

Question 8

A business house wishes to simultaneously elevate two of its six branch heads. In how many ways these elevations can take place?

- (a) 12 (b) 3
(c) 6 (d) 15

Answer: d**Explanation:**

$${}^6 C_2 = \frac{6 \times 5}{2} = 15$$

JULY 2021**Question 1**

If ${}^n P_6 = 20 {}^n P_4$ then the value of n is given by

- (a) n = 5 (b) n = 3
(c) n = 9 (d) n = 8

Answer: Options (c)**Explanation:**

By option Method

Taking n = 9

$${}^4 P_6 = 20 {}^9 P_4$$

$$6040 = 20 \times 3024$$

$$60480 = 60480$$

Question 2

How many number of seven digit numbers which can be formed for the digits 3,4,5,6,7,8,9 no digits being repeated are not divisible by 5?

- (a) 4320 (b) 4690
(c) 3900 (d) 3890

Answer: Options (a)

If no should not $\div 5$ then 5 not on last place (3,4,5,6,7,8,9)

$$= 6 \times 5 \times 4 \times 3 \times 2 \times 1 \times 6$$

$$= 4320$$

Question 3

A person can go from place 'A' to 'B' by 11 different modes of transport but is allowed to return back to "A" by any mode other than the one earlier. The number of different ways, the entire journey can be complete is_

- (a) 110 (b) 10^{10}
(c) 9^5 (d) 10^9

Answer: Options (a)

If a person has 11 ways of going and cannot come from same place 10 ways of coming $11 \times 10 = 110$

Question 4

The number of ways 5 boys and 5 girls can be seated at a round table, so no two boys are adjacent is__

- (a) 2550 (b) 2880
(c) 625 (d) 2476

Answer: Options (b)

Explanation:

5 boys can sit around the circular table in $(5-1)! = 4!$ Ways

For boys and girls to occupy alternate positions, 5 girls has to sit in the gap between the 5 boys.

The girls can be arranged in these gaps in $5!$ ways

Therefore, total number of seating arrangements = $4! * 5! = 24 * 120 = 2880$

DEC 2021

Question 1

The number of four letter words can be formed using the letters of the word DECTIONARY is

- (a) 5040 (b) 720
(c) 30240 (d) 90

Answer: a

Explanation:

There are 10 letters in the word DECTIONARY. 4 letters can be selected and arranged out of these 10 letters in ${}^{10}C_4 \times 4!$ ways.

Therefore,

$${}^{10}C_4 \times 4! = \frac{10 \times 9 \times 8 \times 7}{1 \times 2 \times 3 \times 4} \times 4! = 5,040$$

Question 2

The number of words that can be formed using the letters of the "PETROL" such that the words do not have "P" in the first position, is

- (a) 720 (b) 120
(c) 600 (d) 540

Answer: c

Explanation:

We have 6 places to fill:

The first place can be filled either with E, T, R, O, or L, i.e., in 5 ways.

Suppose you fill the first place with T. Now, the second place can be filled either with P, E, R, O, or L, i.e., in 5 ways.

Suppose you fill the second place with P. Now, the third place can be filled either with E, R, O, or L, i.e., in 4 ways.

Suppose you fill the third place with E. Now, the fourth. be filled either with R, O, or L, i.e., in 3 ways.

Suppose you fill the fourth place with R. Now, the Can fifth be filled either with O, or L, i.e., in 2 ways.

Suppose you fill the fifth place with O. Now, the sixth place cab be filled either with L, i.e., in 1 way.

Therefore, the number of words that can be formed = $5 \times 5 \times 4 \times 3 \times 2 \times 1 = 600$

Question 3

If ${}^nP_2 = 12$, then the value of n is

- (a) 2 (b) 3

(c) 4

(d) 6

Answer: c**Explanation:**

Try the options.

Option (a) – 2

$${}^2P_2 = 2$$

Option (b) – 3

$${}^3P_2 = 3 \times 2 = 6$$

Option (c) – 3

$${}^4P_2 = 4 \times 3 = 12$$

Question 4

The number of different ways the letters of the word "DETAIL" can be arranged in such a way that the vowels can occupy only the odd position is

(a) 32

(b) 36

(c) 48

(d) 60

Answer:**Explanation:**

Vowels: E, A I

Consonants: D, T, L

These are six places to be filled:

1 2 3 4 5 6

There are three odd positions, i.e., 1, 3 and 5. Also, there are three vowels. Therefore, three vowels can be arranged in 3 places in $3!$ Ways.

Similarly, the 3 consonants can be arranged in the positions 2, 4, and 6 in $3!$ Ways.

Therefore, total number of ways = $3! \times 3! = 6 \times 6 = 36$.

Question 5

Six boys and five girls are to be seated for a photograph in a row such that no two girls sit together and no two boys sit together. Find the number of ways in which this can be done.

(a) 74,200

(b) 96,900

(c) 45,990

(d) 86,400

Answer:**Explanation:**

No. of Boys = 6

No. of Girls = 5

$$B_1 \times B_2 \times B_3 \times B_4 \times B_5 \times B_6$$

$$\text{No. of ways} = {}^5P_4 = 6!$$

$$= 5! \times 6!$$

$$= 120 \times 720$$

$$= 86,400$$

JUNE 2022

Question 1

If a man travels from place A to B in 10 ways then by hoe many ways can become back by another train?

- (a) 94 (b) 110
(c) 90 (d) 99

Answer: Options (c)

Explanation:

$$\begin{aligned}\text{No. of ways} &= 10 \times 9 \\ &= 90\end{aligned}$$

Question 2

If four words are taken with or without meaning from the word 'Logarithm' without repetition. How many words will be formed?

- (a) 5040 (b) 2520
(c) 120 (d) 40320

Answer: Options (a)

Explanation:

'Logarithm'

Here $n = 10$ and $r = 4$

No. of ways = ${}^n P_r$

$$\begin{aligned}&= {}^{10} P_4 \\ &= \frac{{}^L 10}{{}^L 10 - 4} = \frac{{}^L 10}{{}^L 6} \\ &= \frac{10 \times 9 \times 8 \times 7}{{}^L 6} \\ &= 5040\end{aligned}$$

Question 3

If $\frac{n!}{10} = \frac{(n-1)!}{(n-1-n+3)!}$, find 'n'.

- (a) 4 (b) 5
(c) 6 (d) 7

Answer: Options (b)

Explanation:

$$\begin{aligned}\text{If } \frac{n!}{10} &= \frac{(n-1)!}{(n-1-n+3)!} \\ \frac{n(n-1)!}{10} &= \frac{(n-1)!}{2!} \\ \frac{n}{10} &= \frac{1}{2} \Rightarrow 2n = 10 \\ n &= 5\end{aligned}$$

Question 4

7 boys and 4 girls from which a team of 5 is to be selected, each team should have atleast one girl is:

- (a) 429 (b) 439
(c) 419 (d) 441

Answer: Options (d)

Explanation:

Boys	Girls
7	4

If at least one girl is selected then it may be following cases:

- (a) 1 Girls and 4 Boys = ${}^4 C_1 \times {}^7 C_4 = 4 \times 35 = 140$
(b) 2 Girls and 3 Boys = ${}^4 C_2 \times {}^7 C_3 = 6 \times 35 = 210$

- (c) 3 Girls and 2 Boys = ${}^4C_3 \times {}^7C_2 = 4 \times 21 = 84$
 (d) 4 Girls and 1 Boys = ${}^4C_4 \times {}^7C_1 = 1 \times 7 = 7$
 Total No of ways = $140+210+84+7$
 = 441

Question 5

8 people are seated in a row in a meeting among them the president and vice president are to be seated always in the centre. What is the arrangement?

- (a) $7!2!$ (b) $6!2!$
 (c) $6!$ (d) $1!$

Answer: Options (b)

Explanation:

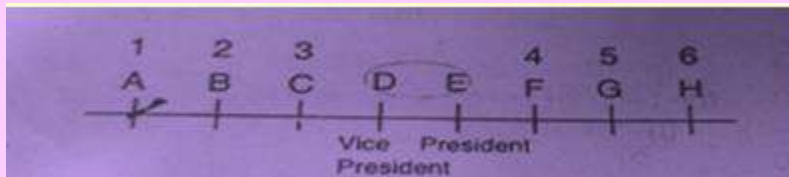

No. of ways = $6! \times 2!$

Question 6

There are 5 questions each have four options. Then in how many different ways can we answer the question?

- (a) 20 (b) 120
 (c) 1024 (d) 60

Answer: Options (c)

Explanation:

No. of ways = n^r

Here $n = 4, r = 5$

$$= 4^5$$

$$= 1024$$

Question 7

If there are 6 points in a line and 4 points in another line. Find the number of parallelogram formed?

- (a) 80 (b) 70
 (c) 90 (d) 100

Answer: Options (c)

Explanation:

No. of Parallelogram = ${}^mC_2 \times {}^nC_2$

Here, $m = 6, n = 4$

$$= {}^6C_2 \times {}^4C_2$$

$$= 15 \times 6$$

$$= 90$$

Question 8

If ${}^{11}C_x = {}^{11}C_{2x-4}$ and $x \neq 4$, then value of 7C_x

- (a) 20 (b) 21

(c) 22

(d) 23

Answer: Options (b)**Explanation:**If ${}^{11}C_x = {}^{11}C_{2x-4}$ [\therefore if ${}^nC_x = {}^nC_y$, then $n = n + y$]then, $x + 2n - 4 = 11$ $3n = 15$

$$n = \frac{15}{3} = 5$$

$${}^7C_n = {}^7C_5 = {}^7C_2 = \frac{7 \times 6}{2 \times 1} = 21$$

DEC 2022

Question 1

There are 20 points in a plane area. How many triangles can be formed by these points if 5 points are collinear?

a) 550

b) 560

c) 1130

d) 1140

Answer: Options (d)**Explanation:**

To get a triangle, three points must be connected. Hence, we have to select 3 points from 20 points.

Therefore,

$${}^{20}C_3 = \frac{20!}{17! \times 3!} = \frac{20 \times 19 \times 18}{3 \times 2} = 1140$$

Question 2

The number of ways 4 boys and 3 girls can be seated in a row so that they are alternate is:

a) 12

b) 288

c) 144

d) 256

Answer: Options (c)**Explanation:**

B G B G B G B

4 boys take their seats in 4! ways 3 girls take their seats in 3! ways Required number = 4! x 3!

= 24 x 6

= 144

Question 3

If $n_{Pr} = 3024$ and $n_{Cr} = 126$, then find n and r

a) 9, 4

b) 10, 3

c) 12, 4

d) 11, 4

Answer: Options (a)**Explanation:**

$$n_{Pr} = 3024 = 72 \times 42 = 9 \times 8 \times 7 \times 6 = \frac{9!}{(9-4)!} = {}_9P_4$$

Hence $(n, r) = (9, 4)$

CHAPTER - 6 SEQUENCE AND SERIES-ARITHMETIC AND GEOMETRIC PROGRESSIONS

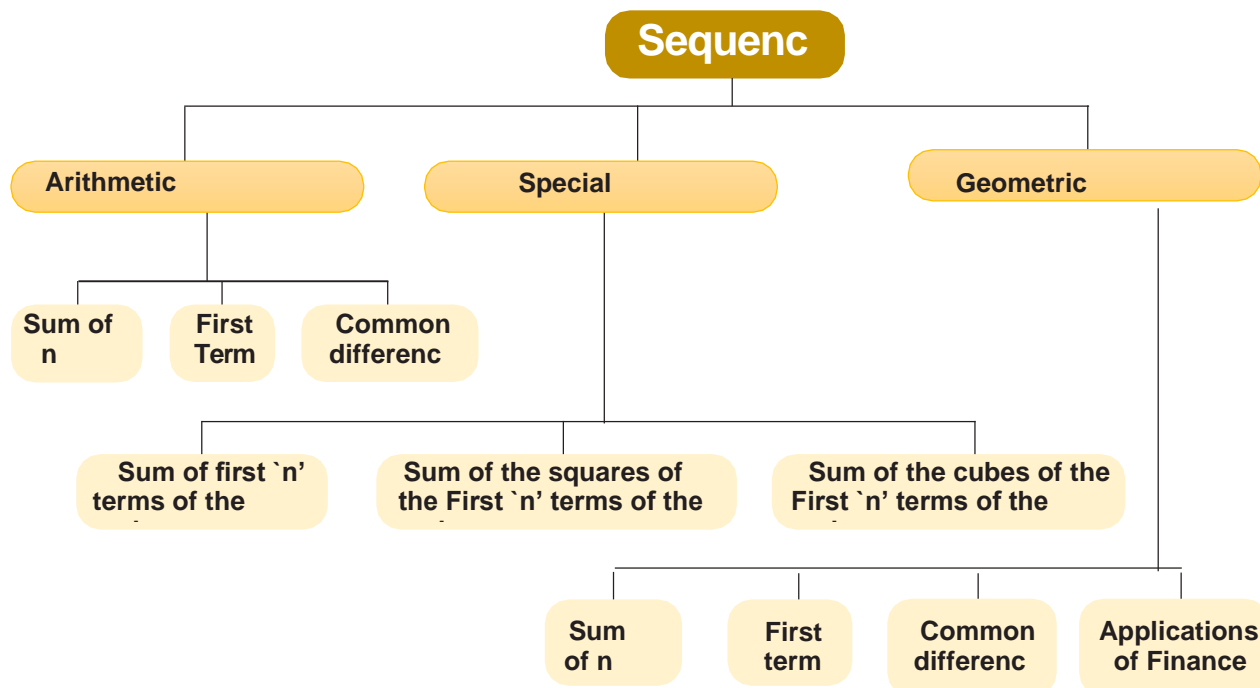

SEQUENCE

An ordered collection of numbers $a_1, a_2, a_3, a_4, \dots, a_n, \dots$ is a sequence if according to some definite rule or law, there is a definite value of a_n , called the term or element of the sequence, corresponding to any value of the natural number n .

An expression of the form $a_1 + a_2 + a_3 + \dots + a_n + \dots$ which is the sum of the elements of the sequence $\{a_n\}$ is called a *series*. If the series contains a finite number of elements, it is called a *finite series*, otherwise called an infinite series.

ARITHMETIC PROGRESSION

A sequence $a_1, a_2, a_3, \dots, a_n$ is called an Arithmetic Progression (A.P.) when $a_2 - a_1 = a_3 - a_2 = \dots = a_n - a_{n-1}$. That means A. P. is a sequence in which each term is obtained by adding a constant d to the preceding term. This constant ' d ' is called the *common difference* of the

	<p>A.P. If 3 numbers a, b, c are in A.P., we say $b - a = c - b$ or $a + c = 2b$; b is called the arithmetic mean between a and c.</p> <p>n^{th} term (t_n) = $a + (n - 1)d$</p> <p>Where a = First Term D = Common difference = $t_n - t_{n-1}$</p> <p>Sum of 1st n natural or counting numbers</p>	
	Sum of n terms of AP	$s = \frac{n}{2}[2a + (n-1)d]$
	Sum of the first n terms	Sum of 1st n natural or counting numbers $S = n(n + 1)/2$
	Sum of 1st n odd number	$S = n^2$
	Sum of the Squares of the first, n natural numbers	$\frac{n(n + 1)(2n + 1)}{6}$
GEOMETRIC PROGRESSION (G.P)	<p>If in a sequence of terms each term is constant multiple of the preceding term, then the sequence is called a Geometric Progression (G.P). The constant multiplier is called the common ratio.</p> <p>$\frac{\text{Any term}}{\text{Preceding term}} = \frac{t_n}{t_{n-1}}$</p> <p>$= \frac{ar^{n-1}}{ar^{n-2}} = r$</p>	
	Sum of first n terms of a GP	$S_n = a(1 - r^n) / (1 - r)$ when $r < 1$ $S_n = a(r^n - 1) / (r - 1)$ when $r > 1$
	Sum of infinite geometric series	$S_\infty = a / (1 - r)$ where $0 < r < 1$
GEOMETRIC MEAN	<p>A.M. of a & b is $= (a+b)/2$</p> <p>If a, b, c are in G.P we get $b/a = c/b \Rightarrow b^2 = ac$, b is called the geometric mean between a and c</p>	

**Question: 1**

Find the 7th term of the A.P. 8, 5, 2, -1, -4, ...

For more Info Visit - www.KITest.in

- (a) 10 (b) -10
(c) 8 (d) -8

Answer: b

Explanation:

Here $a = 8$, $d = 5 - 8 = -3$

Now $t_7 = 8 + (7-1)d$

$= 8 + (7 - 1)(-3)$

$= 8 + 6(-3)$

$= 8 - 18$

$= -10$

Question: 2

If 5th and 12th terms of an A.P. are 14 and 35 respectively, find the A.P.

- (a) 2, 5, 8, 11, 14,..... (b) 2, 3, 8, 11, 12,.....
(c) 2, 3, 4, 11, 14 ... (d) 2, 5, 8, 1, 4,.....

Answer: a

Explanation:

Let a be the first term & d be the common difference of A.P.

$t_5 = a + 4d = 14$

$t_{12} = a + 11d = 35$

On solving the above two equations

$7d = 21$ i.e. $d = 3$

And $a = 14 - (4 \times 3) = 14 - 12 = 2$

Hence, the required A.P. is 2, 5, 8, 11, 14,.....

Question: 3

Divide 69 into three parts are in A.P. and are such that the product of the first two parts is 483.

- (a) 21, 23, 25. (b) 21, 22, 23,
(c) 22, 23, 25. (d) 21, 22, 25.

Answer: a

Explanation:

Given that three parts are in A.P., let the three parts which are in A.P. be $a - d$, a , $a + d$

Thus $a - d + a + a + d = 69$

Or $3a = 69$

Or $a = 23$

So the three parts are $23 - d$, 23 , $23 + d$

Since the product of first two parts is 483, therefore, we have $23(23 - d) = 483$

Or $23 - d = \frac{483}{23} = 21$

Or $d = 23 - 21 = 2$

Hence, the three parts which are in A.P. are $23 - 2 = 21$, 23 , $23 + 2 = 25$

Hence the three parts are 21, 23, and 25

Question: 4

Find the arithmetic mean between 4 and 10.

- (a) 5 (b) 7
(c) 10 (d) 3

Answer: b

Explanation:

We know that the A.M. of a & b is $= (a + b) / 2$

Hence, The A.M. between 4 & 10 $= (4 + 10) / 2 = 7$

Question: 5

Find the G.P. series where 4th term is 8 and 8th term is 128/625

(a) 125, 50, 20, 9,

(b) 125, 50, 20, 10,

(c) 125, 5, 20, 8...

(d) 125, 50, 20, 8 ...

Answer: d

Explanation:

$$t_4 = ar^3 = 8$$

$$T_8 = 128/625 \rightarrow ar^7 = 128/625$$

$$T_8/T_4 = 128/625 \times 1/8$$

$$\rightarrow ar^7/ar^3 = 16/625$$

$$\rightarrow r^4 = 2^4/5^4$$

$$\rightarrow r = 2/5$$

$$ar^3 = 8$$

$$\rightarrow a (2/5)^3 = 8$$

$$\rightarrow a \times 8/125 = 8$$

$$\rightarrow a = 125$$

Therefore, $a = 125$, $ar = 125 \times 2/5 = 50$, $ar^2 = 125 \times 4/125 = 20$

Or 125, 50, 20, 8... Forms a G.P.

Question: 6

Insert three geometric means between $\frac{1}{9}$ and 9

(a) $\frac{1}{9}, \frac{1}{3}, 1, 3, 9$

(b) $\frac{1}{8}, \frac{1}{5}, 1, 3, 9$

(c) $\frac{11}{9}, \frac{1}{3}, 1, 3, 9$

(d) $\frac{121}{9}, \frac{1}{3}, 1, 3$

Answer: a

Explanation:

G.P. Series $\frac{1}{9}, \dots, \dots, \dots, 9$

$$\text{Here } t_1 = a = \frac{1}{9}$$

$$t_5 = a.r^4 = 9$$

$$\text{Now, } t_5 = \frac{1}{9}.r^4 = 9$$

$$= r^4 = 81$$

$$= r^4 = 3^4$$

$$= r = 3$$

$$t_2 = ar = \frac{1}{9} \times 3 = \frac{1}{3}$$

$$t_3 = ar^2 = \frac{1}{9} \times 3^2 = 1$$

$$t_4 = ar^3 = \frac{1}{9} \times 3^3 = 3$$

Thus the series $\frac{1}{9}, \frac{1}{3}, 1, 3, 9$

Question: 7

Find the sum of 1st term of G.P. series 1+2+4+8+.....

- (a) 155 (b) 255
(c) 185 (d) -822

Answer: b

Explanation:

Here $a = 1, r = 2, n = 8$

$$S_n = a \cdot \frac{(r^n - 1)}{(r - 1)} \text{ When } r > 1$$

$$S_8 = 1 \cdot \frac{(2^8 - 1)}{(2 - 1)}$$

$$= 1 (256 - 1) = 255$$

Thus $S_8 = 255$

Question: 8

Find the sum of the series -2, 6, -187 terms?

- (a) 1554 (b) -1094
(c) 1094 (d) -8223

Answer: b

Explanation:

Here $a = -2, r = -3, n = 7$

$$S_n = a \cdot \frac{(1 - r^n)}{(1 - r)} \text{ When } < 1$$

$$S_7 = (-2) \frac{[1 - (-3)^7]}{[1 - (-3)]}$$

$$= (-2) \frac{(1 + 2187)}{4}$$

$$= (-2) \frac{(2188)}{4}$$

$S_7 = -1094$

Question: 9

In a G.P. the product of the 1st three terms 27/8. The middle term is

- (a) $\frac{27}{8}$ (b) $\frac{3}{2}$
(c) $\frac{2}{9}$ (d) $\frac{8}{27}$

Answer: b

Explanation:

Let the three terms Of GP are $\frac{a}{r}, a, ar$

Now product of terms

$$\frac{a}{r} \times a \times ar = \frac{27}{8}$$

$$a^3 = \frac{27}{8}$$

$$a^3 = \left(\frac{3}{2}\right)^3$$

$$a = \frac{3}{2}$$

Thus the middle term, $a = \frac{3}{2}$

Question: 10

If you save 1 paisa today, 2 paisa the next day and 4 paisa the succeeding day and so on, then your total savings in two weeks will be.

For more Info Visit - www.KITest.in

- (a) Rs. 168.32 (b) Rs. 163.98
 (c) Rs. 163.83 (d) None

Answer: c

Explanation:

Here the pattern of savings the G.P series 0.01, 0.02, 0.04 ...

Here $a = 0.01$, $r = 2$, $n = 14$

$$S_n = a \cdot \frac{(r^n - 1)}{(r - 1)} \text{ When } r > 1$$

$$S_{14} = 0.01 \frac{(2^{14} - 1)}{(2 - 1)}$$

$$= 0.01 \frac{(16384 - 1)}{1}$$

$$= 0.01 \times 16383$$

$$S_{14} = 163.83$$

Thus the total savings in 14 days would be Rs. 163.83.

Question: 11

The sum of the infinite G.P series $1 - \frac{1}{3} + \frac{1}{9} - \frac{1}{27} + \dots$

- (a) 0.75 (b) 75
 (c) 0.57 (d) 57

Answer: a

Explanation:

Here $a = 1$, $r = \left(\frac{-1}{3}\right)$

$$S_{\infty} = \frac{a}{(1-r)} = \frac{1}{\left[1 - \left(\frac{-1}{3}\right)\right]}$$

$$=$$

$$= 1 / \left[4/3\right]$$

$$= \frac{3}{4}$$

$$= 0.75$$

Question: 12

Find the 10th term of the A.P.: 2, 4, 6,

- (a) 20 (b) 40
 (c) 2 (d) 0.20

Answer: a

Explanation:

Here the first term $(a) = 2$ and common different $d = 4 - 2 = 2$

Using the formula $t_n = a + (n - 1) d$, we have

$$t_{10} = 2 + (10 - 1) 2 = 2 + 18 = 20$$

Hence, the 10th term of the given A.P. is 20

Question: 13

The 10th term of an A.P. is -15 and 31st term is -57, find the 15th term

- (a) -20 (b) 20
 (c) -25 (d) 25

Answer: c

Explanation:

Let a be the first term and d be the common difference of the A.P. Then from the formula:

$t_n = a + (n - 1) d$, we have

$$t_{10} = a + (10 - 1) d = a + 9d$$

$$t_{31} = a + (31 - 1) d = a + 30 d$$

We have,

$$a + 9d = -15 \quad \dots (1)$$

$$a + 30d = -57 \quad \dots (2)$$

Solve equations (1) and (2) to get the values of a and d. Subtracting (1) from (2), we have

$$21d = -57 + 15 = -42$$

$$-42 \div 21 = 2$$

$$\text{Again from (1), } a = -15 - 9d = -15 - 9(-2) = -15 + 18 = 3$$

$$\text{Now } t_{15} = a + (15 - 1) d$$

$$= 3 + 14(-2) = -25$$

Question: 14

Which term of the A.P.: 5, 11, 17 ... is 119?

(a) $n = 20$

(b) $n = 2$

(c) $n = 30$

(d) $n = 19$

Answer: a

Explanation:

Here $a = 5$, $d = 11 - 5 = 6$

$t_n = 119$ we know that

$$t_n = a + (n - 1) d$$

$$? 119 = 5 + (n - 1) \times 6$$

$$(n - 1) = \frac{119 - 5}{6} = 19$$

$n = 20$, therefore, 119 is the 20th term of the given A.P.

Question: 15

Is 600 a term of the A. P.: 2, 9, 16,?

(a) yes

(b) no

(c) not sure

(d) none

Answer: b

Explanation:

Here, $a = 2$, and $d = 9 - 2 = 7$.

Let 600 be the n^{th} term of the A.P. We have $t_n = 2 + (n - 1) 7$

According to the question

$$2 + (n - 1) 7 = 600$$

$$(n - 1) 7 = 598$$

$$\text{Or } n = \frac{598}{7} + 1 \qquad n = 86\frac{3}{7}$$

Since n is a fraction, it cannot be a term of the given A.P. Hence, 600 is not a term of the given A.P.

Question: 16

The common difference of an A.P. is 3 and the 15th term is 37. Find the first term.

(a) -5

(b) 5

(c) 42

(d) -42

Answer: a

Explanation:

Here $d = 3$, $t_{15} = 37$, and $n = 15$ Let the first term be a . we have

$$t_n = a + (n-1)d$$

$$37 = a + (15 - 1)3$$

Or, $37 = a + 42$
 $a = -5$

Thus, first term of the given A.P. is -5

Question: 17

Geometric mean G between two numbers a and b is

- (a) ab (b) ab^2
 (c) a^2b (d) \sqrt{ab}

Answer: d

Explanation:

If a single geometric mean 'G' is inserted between two given numbers 'a' and 'b', then G is known as the geometric mean between 'a' and 'b'.

$$G.M. = G = G^2 = \sqrt{ab}$$

Question: 18

If A and G are arithmetic and geometric mean respectively between two positive numbers a and b, then A (AM) < G (GM) is correct?

- (a) yes (b) no
 (c) not sure (d) none

Answer: b

Explanation:

We have

$$A.M. = A = \frac{a+b}{2} \text{ and } G.M. = G = \sqrt{ab}$$

$$A - G = \frac{a+b}{2} - \sqrt{ab}$$

$$= \frac{a+b-2\sqrt{ab}}{2}$$

$$= (\sqrt{a} - \sqrt{b})^2$$

Root will be open automatically

$$A - G > 0$$

$$\rightarrow A > G$$

Question: 19

Find the sum of the AP: 11, 17, 23, and 29... of first 10 terms.

- (a) 380 (b) 568
 (c) 960 (d) 593

Answer: a

Explanation:

$$\Rightarrow \text{nth term for the given AP} = 5 + 6n$$

$$\Rightarrow \text{First term} = 5 + 6 = 11$$

$$\Rightarrow \text{Tenth term} = 5 + 60 = 65$$

$$\Rightarrow \text{Sum of 10 terms of the AP} = 0.5n (\text{first term} + \text{last term}) = 0.5 \times 10 (11 + 65)$$

$$\Rightarrow \text{Sum of 10 terms of the AP} = 5 \times 76 = 380$$

Question: 20

Find the G. M. between $\frac{3}{2}$ and $\frac{27}{2}$

(a) $\frac{9}{2}$
(c) $\frac{6}{3}$

(b) $\frac{2}{9}$
(d) $\frac{3}{6}$

Answer: a**Explanation:**

We know that if a is the G. M. between a and b, then

$$G = \sqrt{ab}$$

$$\begin{aligned} \text{G. M. between } \frac{3}{2} \text{ and } \frac{27}{2} &= \sqrt{\frac{3}{2} \times \frac{27}{2}} \\ &= \frac{9}{2} \end{aligned}$$

Question: 21**Insert three geometric means between 1 and 256.**

- (a) 4, 16, 64, (b) -4, 16, -64
(c) Both (d) None

Answer: c**Explanation:**Let G_1, G_2, G_3 , be 3
GMS both 1, & 256

Then,

1, $G_1, G_2, G_3, 256$ will be in GP

Let common ratio be r

$$\therefore G_1 = r$$

$$\text{So } r^4 = 256$$

$$r = \pm 4$$

$$G_1 = \pm 4$$

$$G_2 = \pm 16$$

$$G_3 = \pm 64$$

Question: 22**If 4, 36, 324 are in G.P. insert two more numbers in this progression so that it again forms a G.P.**

- (a) 12, 108 (b) 14, 180
(c) 16, 120 (d) 12, 10

Answer: a**Explanation:**

$$\text{G. M. between 4 and 36} = \sqrt{4 \times 36} = \sqrt{144} = 12$$

$$\text{G.M. between 36 and 324} = \sqrt{36 \times 324} = 6 \times 18 = 108$$

If we introduce 12 between 4 and 36 and 108 between 36 and 324, the numbers 4, 12, 36, 108, 324 form a G.P.

The two new numbers inserted are 12 and 108.

Question: 23**The distance travelled (in cm) by a simple pendulum in consecutive seconds are 16, 12, 9,.... How much distance will it travel before coming to rest?**

- (a) 64 cm (b) 46 cm
(c) 1 am (d) none

Answer: a

Explanation:

The distance travelled by the pendulum in consecutive seconds are, 16, 12, 9 ... is an infinite geometric progression with the first term $a = 16$ and $r = \frac{12}{16} = \frac{3}{4} < 1$

Hence, using the formula $S = \frac{a}{1-r}$ we have

$$S = \frac{16}{1-\frac{3}{4}} = \frac{16}{\frac{1}{4}} = 64$$

Distance travelled by the pendulum is 64 cm.

Question: 24

Which term of the G.P.: 5, -10, 20, -40,... is 320?

- (a) 7 (b) 6
(c) 3 (d) 12

Answer: a

Explanation:

In this case, $a = 5$; $r = \frac{-10}{5} = -2$

Suppose that 320 is the n^{th} term of the G. P.

By the formula $t = ar^{n-1}$, we get

$t = 5 \cdot (-2)^{n-1}$, we get

$$320 = 5 \cdot (-2)^{n-1} = 64 = (2)^6 = (-2)^{n-1}$$

$$n - 1 = 6$$

$$n = 7$$

Hence 320 is the 7th term of the G.P.

Question: 25

If a, b, c is in G.P., then

- (a) $a(b^2 + a^2) = c(b^2 + c^2)$ (b) $a(b^2 + a^2) = c(a^2 + b^2)$
(c) $b(b^2 + a^2) = c(b^2 + c^2)$ (d) None

Answer: b

Explanation:

If a, b, c is in to G.P. Then $b^2 = ac$

$$b^2(a - c) = ac(a - c)$$

$$b^2a - ac^2 = a^2c - b^2c$$

$$a(b^2 + c^2) = c(a^2 + b^2)$$

Trick: Put $a=1, b=2, c=4$, and check the alternates.

Question: 26

The sum of infinity of the progression $9-3+1-\frac{1}{3}+ \dots$ is

- (a) 9 (b) 9/2
(c) 27/4 (d) 15/2

Answer: c

Explanation:

Infinite series $9-3+1-\frac{1}{3} \dots \infty$ is a G. P. with

$$a = 9, r = \frac{-1}{3} \setminus S_{\infty} = \frac{a}{1-r} = \frac{9}{1+\frac{1}{3}} = \frac{9 \times 3}{4} = \frac{27}{4}$$

Question: 27

The product $(32)(32)^{1/6}(32)^{1/36} \dots \text{To } \infty$ is.

- (a) 16 (b) 32
(c) 64 (d) 0

Answer: c

Explanation:

$$(32) (32)^{1/6} (32)^{1/36} \dots \infty = (32)^{1 + \frac{1}{6} + \frac{1}{36} + \dots \infty} = (32)^{\left(1 - \frac{1}{6}\right)}$$

$$(32)^{\frac{1}{5/6}} = (35)^{6/5} = 2^6 = 64$$

Question: 28

Obtain the sum of all positive integers up to 1000, which are divisible by 5 and not divisible by 2.

- (a) 10050 (b) 5050
(c) 5000 (d) 50000

Answer: d

Explanation:

The positive integers, which are divisible by 5, are 5, 10, 15... 1000

Out of these 10, 20, 30,.. 1000 are divisible by 2

Thus, we have to find the sum of the positive integers 5, 15, 25... 995

If n is the number of terms in it the sequence then

$$995 = 5 + 10(n-1)$$

$$\Rightarrow 1000 = 10n$$

Therefore, n = 100

Thus the sum of the series = $(100/2) (5 + 995) = (50) (1000) = 50000$.

Question: 29

If s is the sum of an infinite G.P., the first term a then the common ratio r given by

- (a) $\frac{a-s}{s}$ (b) $\frac{s-a}{s}$
(c) $\frac{a}{1-s}$ (d) none

Answer: b

Explanation:

$$S = \frac{a}{1-r}$$

$$s - sr = a$$

$$-sr = a - s$$

$$r = \frac{s-a}{s}$$

Question: 30

If in an infinite G.P. first term is equal to the twice of the sum of the remaining terms, then its common ratio is

- (a) 1 (b) 2
(c) 1/3 (d) -1/3

Answer: c

Explanation:

$$\text{Given, } a = 2 \left(\frac{ar}{1-r} \right)$$

$$1-r = 2r$$

$$r = \frac{1}{3}$$

Question: 31

If n geometric means between a and b be G_1, G_2, \dots, G_n and a geometric mean be G, then the true relation is

- (a) $G_1, G_2, \dots, G_n = G$ (b) $G_1, G_2, \dots, G_n = G^{1/n}$
 (c) $G_1, G_2, \dots, G_n = G^n$ (d) none

Answer: c

Explanation:

Here $G = (a b)^{1/2}$ and

$G_1 = ar^1, G_2 = ar^2, \dots, G_n = ar^n$. therefore
 $G_1 \cdot G_2 \cdot G_3 \dots G_n = a^n r^{1+2+\dots+n} = a^n r^{n(n+1)/2}$ But
 $ar^{n+1} = b$

$$r = \left(\frac{b}{a}\right)^{\frac{1}{n+1}}$$

Therefore, the required product is $a^n \left(\frac{b}{a}\right)^{\frac{1}{(n+1)} \cdot n(n+1)/2}$
 $= (ab)^{n/2}$
 $= \{(ab)^{1/2}\}^n$
 $= G^n$

Note: It is a well-known fact.

Question: 32

7th term of the sequence $\sqrt{2}, \sqrt{10}, 5\sqrt{2} \dots$ is

- (a) $125\sqrt{10}$ (b) $25\sqrt{2}$
 (c) 125 (d) $125\sqrt{2}$

Answer: D

Explanation:

Given sequence is $\sqrt{2}, \sqrt{10}, 5\sqrt{2} \dots$. Common ratio

$r = \sqrt{5}$, first term $a = \sqrt{2}$, then 7th term

$$t_7 = \sqrt{2}(\sqrt{5})^{7-1} = \sqrt{2}(\sqrt{5})^6 = \sqrt{2}(5)^3$$

$$125\sqrt{2}$$

Question: 33

If the first term of a G.P. be 5 and common ratio be -5, then which term is 3125?

- (a) 6th (b) 5th
 (c) 7th (d) 8th

Answer: b

Explanation:

Given that first term $a=5$ and common ratio $r=-5$. Suppose that n^{th} term is 3125

Then $ar^{n-1} = 3125$

$$5(-5)^{n-1} = \frac{5^5}{5} 5^4$$

$$n - 1 = 4 = (n \rightarrow 5)$$

Question: 34

The sums of n terms of three A.P.'s whose first term is 1 and common differences are 1, 2, 3 are S_1, S_2, S_3 respectively. The true relation is

- (a) $S_1 + S_2 = S_3$ (b) $S_1 + S_3 = 2S_2$
 (c) $S_1 + S_2 = 2S_3$ (d) none

Answer: b

Explanation:

We have $a_1 = a_2 = a_3 = 1$

$$d_1 = 1, d_2 = 2, d_3 = 3$$

Therefore, $S_1 = \frac{n}{2}(n + 1) \dots (i)$

$$S_2 = \frac{n}{2}(2n + 1) \dots (ii)$$

$$S_3 = \frac{n}{2}(3n + 1)$$

... (iii) Adding (i) and (iii),

$$S_1 + S_3 = \frac{n}{2}[(n + 1) + (3n + 1)] \rightarrow \frac{n}{2}[4n + 2]$$

$$= 2\left[\frac{n}{2}(2n + 1)\right] = 2S_2$$

Hence correct relation $S_1 + S_3 = 2S_2$

Question: 35

What is the sum of all 3 digit numbers that leave a remainder of '2' when divided by 3?

(a) 897

(b) 164,850

(c) 164,749

(d) 149,700

Answer: b

Explanation:

The smallest 3 digit number that will leave a remainder of 2 when divided by 3 is 101.

The next number that will leave a remainder of 2 when divided by 3 is 104, 107,

The largest 3 digit number that will leave a remainder of 2 when divided by 3 is 998.

So, it is an AP with the first term being 101 and the last term being 998 and common difference being 3.

Sum of an AP = $\frac{\text{First term} + \text{Last term}}{2} \times \text{Number of term}$

We know that in an A.P., the nth term $a_n = a_1 + (n - 1) \cdot d$

In this case, therefore, $998 = 101 + (n - 1) \cdot 3$

i.e. $897 = (n - 1) \cdot 3$

Therefore $n - 1 = 299$

Or $n = 300$

Sum of the AP will therefore be $\frac{101 + 998}{2} \times 300 = 164,850$

Question: 36

What is the sum of the following series? -64, -66, -68, ..., -100

(a) -1458

(b) -1558

(c) -1568

(d) -1664

Answer: b

Explanation:

The sequence is -64, -66, -68, ..., -100.

The given set of numbers are in an arithmetic progression

Key data: First term is -64. The common difference is -2. The last term is -100

Sum of the first n term is an AP = $\frac{n}{2}[2a_1 + (n-1)d]$

To compute the sum, we know the first term $a_1 = -64$ and the common difference $d = -2$

We do not know the number of terms n. Let us first compute the number of terms and then find the sum of the terms.

Step to compute number of terms of the sequence

$$a_n = a_1 + (n - 1)d$$

$$-100 = -64 + (n - 1)(-2)$$

Therefore, $n = 19$.

$$\text{Sum } S_n = \frac{19}{2}[2(-64) + (919-1)(-2)]$$

$$S_n = \frac{19}{2}[-128-36]$$

$$S_n = 19 \times (-82) = -1558$$

Question: 37

The sum of third and ninth term of an A.P. is 8. Find the sum of the first 11 terms of the progression.

(a) 44

(b) 22

(c) 19

(d) None of these

Answer: a

Explanation:

The third term $t_3 = a + 2d$

The ninth term $t_9 = a + 8d$

$$t_3 + t_9 = 2a + 10d = 8$$

Sum of first 11 terms of an AP is given by

$$S_{11} = \frac{11}{2}[2a + 10d]$$

$$S_{11} = \frac{11}{2}[8] = 44$$

Question: 38

The sum of the three numbers in A.P is 21 and the product of the first and third number of the sequence is 45. What are the three numbers?

(a) 9, 7 and 5

(b) 3, 7, and 11

(c) Both A & B

(d) None of these

Answer: a

Explanation:

Let the number are be $a - d, a, a + d$

$$\text{Then } a - d + a + a + d = 21$$

$$3a = 21$$

$$a = 7$$

$$\text{and } (a - d)(a + d) = 45$$

$$a^2 - d^2 = 45$$

$$d^2 = 4$$

$$d = \pm 2$$

Hence, the number are 5, 7 and 9 when $d = 2$ and 9, 7 and 5 when $d = -2$. In both the cases numbers are the same.

Question: 39

If the first term of G.P. is 7, Its n^{th} term is 448 and sum of first n terms is 889, then find the fifth term of G. P.

(a) 112

(b) 110

(c) 62

(d) 39

Answer: a

Explanation:

Given $a = 7$ the first term $t_n = ar^{n-1} = 7(r)^{n-1} = 448$.

$$7r^n = 448 \quad r \text{ ---- (1)}$$

$$\text{Also } S_n = \frac{a(r^n - 1)}{r - 1} = \frac{7(r^n - 1)}{r - 1}$$

$$889 = \frac{448r^7 - 7}{r - 1} \quad \{\text{value of } r^n \text{ from (1)}\}$$

$$R = 2$$

$$\text{Hence } T_5 = ar^4 = 7(2)^4 = 112$$

Question: 40

If the third and fourth terms of arithmetic sequence are increased by 3 and 8 respectively. Then the first four terms form a geometric sequence. Find

(i) the sum of the first four terms of A.P.

(a) 54

(b) 27

(c) 23

(d) 79

Answer: a

Explanation:

Sol. $a, (a + d), (a + 2d), (a + 3d)$ in A.P.

$a, a + d, (a + 2d + 3), (a + 3d + 8)$ are in G.P.

Hence $a + d = ar$

$$\text{also } r = \frac{a+d}{a} = \frac{a+2d+3}{a+d} = \frac{a+3d+8}{a+2d+3}$$

$$\frac{d+3}{d} = \frac{d+5}{d+3}$$

$$\rightarrow d^2 + 6d + 9 = d^2 + 5d \rightarrow d = -9$$

$$\frac{a-9}{a} = \frac{a-15}{a-9}$$

$$\rightarrow a^2 - 18a + 81 = a^2 - 15a \rightarrow 3a = 81 \rightarrow a = 27$$

Hence A.P. is 27, 18, 9, 0,

Sum of the first four terms of AP = 54

Question: 41

Three positive numbers form a G.P. If the second term is increased by 8, the resulting sequence is an A.P. In turn, if we increase the last term of this A.P. by 64, we get a G.P.

Find the three numbers.

(a) 4, 12, 36

(b) 4, 8, 16

(c) 5, 15, 20

(d) none

Answer: a

Question: 42

The sum of the first five terms of a geometric series is $18r$. The sum of the first six terms is $3r^6$, and the sum of the first seven terms is $7r^5$. What is the common ratio in the series?

(a) 3

(b) 2

(c) 6

(d) 56

Answer: b

Explanation:

Let the numbers be a, ar, ar^2 when $r > 0$

Hence $a, (ar + 8), ar^2$ in A.P. – (1)

Also $a, (ar + 8), ar^2 + 64$ in G.P. – (2)

$$\rightarrow (ar + 8)^2 = a(ar^2 + 64) \quad a = 4/4-r \quad \text{--- (3)}$$

$$\text{Also (1)} \rightarrow 2(ar + 8) = (a + ar^2) \rightarrow (1 - r)^2 = 16/a \quad \text{--- (4)}$$

From (3) and (4) $r = 3$ or -5 (rejected)

Hence $a = 4$ numbers are: 4, 12, 3^6

For more Info Visit - www.KITest.in

Explanation:

$$S_5 = 189; S_6 = 3^{81}; S_7 = 7^{65}; t_6 = S_6 - S_5 = 3^{81} - 189 = 192$$

$$t_7 = S_7 - S_6 = 7^{65} - 3^{81} = 3^{84}$$

$$\text{Now common ratio} = \frac{t_7}{t_6} = \frac{3^{84}}{192} = 2$$

Question: 43

Find the 3rd nth term for the AP: 11, 17, 23, 29,.....

- (a) 23 (b) 17
(c) 11 (d) 6

Answer: a

Explanation:

$$\text{Here, } a = 11, d = 17 - 11 = 23 - 17 = 29 - 23 = 6$$

We know that nth term of an AP is $a + (n - 1) d$

$$\Rightarrow \text{nth term for the given AP} = 11 + (n - 1)6$$

$$\Rightarrow \text{nth term for the given AP} = 11 + (n - 1) 6$$

$$\Rightarrow \text{nth term for the given AP} = 5 + 6n$$

We can verify the answer by putting values of 'n'

$$\Rightarrow n = 1 \rightarrow \text{First term} = 5 + 6 = 11$$

$$\Rightarrow n = 2 \rightarrow \text{Second term} = 5 + 12 = 17$$

$$\Rightarrow n = 3 \rightarrow \text{Third term} = 5 + 18 = 23$$

Question: 44

The sum of three numbers in a GP is 26 and their product is 216. And the numbers.

- (a) 2, 6 and 18 (b) 3, 7, and 11
(c) Both (d) None of these

Answer: a

Explanation:

Let the numbers be $\frac{a}{r}$, a, ar.

$$\Rightarrow \left(\frac{a}{r}\right) + a + ar = 26$$

$$\Rightarrow a \frac{(1+r+r^2)}{r} = 26$$

Also, it is given that product = 216

$$\Rightarrow \left(\frac{a}{r}\right) \times (a) \times (ar) = 216$$

$$\Rightarrow a^3 = 216$$

$$\Rightarrow a = 6$$

$$\Rightarrow 6 \frac{(1+r+r^2)}{r} = 26$$

$$\Rightarrow \frac{(1+r+r^2)}{r} = \frac{26}{6} = \frac{13}{3}$$

$$\Rightarrow 3 + 3r + 3r^2 = 13r$$

$$\Rightarrow 3r^2 - 10r + 3 = 0$$

$$\Rightarrow (r - 3) \left(r - \frac{1}{3}\right) = 0$$

$$\Rightarrow r = 3 \text{ or } r = \frac{1}{3}$$

Thus, the required numbers are 2, 6 and 18.

Question: 45

A Sequence in which the ratio of two consecutive terms is always constant (1, 0) is called

- (a) AP (b) GP

For more Info Visit - www.KITest.in

(c) HP

(d) NP

Answer: b**Explanation:**

A Sequence in which the ratio of two consecutive terms is always constant (1, 0) is called a Geometric progression (G.P.)

Question:46**For the elements 4 and 6, verify**(a) $A \geq G \geq H$ (b) $A < G \geq H$ (c) $A > G \geq H$

(d) None

Answer: a**Explanation:**

$$A = \text{Arithmetic Mean} = (4 + 6) / 2 = 5$$

$$G = \text{Geometric Mean} = \sqrt{4 \times 6} = 4.8989$$

$$H = \text{Harmonic Mean} = (2 \times 4 \times 6) / (4 + 6) = 48 / 10 = 4.8$$

Therefore, $A \geq G \geq H$

Question: 47**A sequence of numbers is called?**

(a) Geometric Progression

(b) Arithmetic progression (AP)

(c) Harmonic Progression

(d) All

Answer: d**Explanation:****Harmonic Progression (HP)**

A sequence of numbers is called a harmonic progression if the reciprocal of the terms are in AP. In simple terms, a, b, c, d, e, f are in HP if $1/a, 1/b, 1/c, 1/d, 1/e, 1/f$ are in AP.

Arithmetic Progression (AP)

A sequence of numbers is called an arithmetic progression if the difference between any two consecutive terms is always same.

Geometric Progression (GP)

A sequence of numbers is called a geometric progression if the ratio of any two consecutive terms is always same.

Question: 48**An AP has 13 terms whose sum is 143. The third term is 5, then first term is:**

(a) 4

(b) 7

(c) 9

(d) None of these

Answer: d**Explanation:**

$$S(13) = 143$$

$$S(13) = (n/2)(2a + (n-1)d)$$

$$= (13/2) \times (2a + 12d)$$

$$= 13 \times (a + 6d)$$

$$= 13a + 78d = 143 \quad \text{----- (1)}$$

Divide both sides by 13

$$a + 6d = 11 \quad \text{..... (1)}$$

$$T(3) = a + 2d = 5 \quad \text{..... (2)}$$

Subtract (2) from (1)

$$4d = 6$$

$$d=3/2$$

Substituted in any of the equations(am using 2)

$$a + 2(3/2) = 5$$

$$a + 3 = 5$$

$$a = 2$$

Question: 49

The series $1^3 + 2^3 + 3^3 + \dots + 20^3$ is equal to

a) 4410

b) 4410000

c) 44100

d) None of these

Answer: c

Explanation

$$(n(n+1)/2)^2$$

$$(20(20+1)/2)^2$$

$$44100.$$

PREPARE FOR WORST

Question 1

What is the sum of all 3 digit numbers that leave a remainder of `2' when divided by 3?

(a) 897

(b) 164,850

(c) 164,749

(d) 149,700

Question 2

A piece of equipment cost a certain factory Rs. 6, 00,000. If it depreciates in value , 15% the first year, 13.5% the next year . 12% the third year , and so on , what will be its value at the end of 10 years , all percentages applying to the original cost

(a) 2,00,000

(b) 1,05,000

(c) 4,05,000

(d) 6,50,000

Question 3

If a rubber ball consistently bounces back $2/3$ of the height from which it is dropped, what

Fraction of its original height will the ball bounce after being dropped and bounced four times without being stopped?

(a) $16/81$

(b) $16/27$

(c) $4/9$

(d) $37/81$

Question 4

Find the sum of first 30 positive integer multiple of 6

Question 5

How many numbers are there between 200 and 800 which are divisible by both? 5 and 7?

Question 6

If $(p + q)$ th term of an A.P is m and $(p-q)$ th term is n , then p th

(a) mn

(b) \sqrt{mn}

(c) $\frac{1}{2}(m - n)$

(d) $\frac{1}{2}(m + n)$

Question 7

If 7 times the 7th term of an A.P is equal to 11 times of its 11th term , then 18th term is

(a) 18

(b) 9

(c) 77

(d) 0

Question 8

There is a set of four numbers p,q,r and s respectively in such a manner that first three are in G.P. and the last three are in A.P with a difference of 6. If the first and the fourth numbers are the same find the value of P.

(a) 8

(b) 2

(c) -4

(d) -24

Question 9

An arithmetic progression has 23 terms, the sum of the middle three terms of the arithmetic progression is 270, and the sum of the last three terms of this Arithmetic progress is 1320. What is the 18th term of this arithmetic progression?

(a) 240

(b) 360

(c) 340

(d) 440

Question 10

Find the value of 'a' given that the geometric mean between x and y is

(a) $-2/3$

(b) $-1/4$

(c) $-3/2$

(d) $-7/6$

Question 11

Sum of three numbers in GP with common ratio greater than 1 is 105 If the first two numbers are multiplied by 4 and the 3rd number is multiplied by 3, then the resulting Terms are in AP. What is the highest of the three numbers given?

(a) 60

(b) 50

(c) 30

(d) 45

Question 12

There are three terms x,y,z between 4&40 such that (i) their sum is 37 (ii) 4,x,y are consecutive terms of an A,P and (iii) y,z,40 are the consecutive terms of a G.P, Find the value of Z

(a) 20

(b) 10

(c) 12

(d) 15

Question 13

A tortoise walks 500 m in one day, the next day it walks 250 m, the next day 125, m and so on, what is the limiting distance which it could walk?

Question 14

In a geometric progression the sum of first 3X term of the series is S and the sum of first 2X terms of the series is $12s/133$. If the sum of first X terms of the series is s/k , find the value of 'k' it is given that the common difference of the gp is positive.

- (a) 120 (b) 133
(c) 155 (d) 160

Question 15

In a infinite geometric progression with common ratios less than 1 the sum of any two consecutive terms is 8 times the sum of all the terms that follow. What is the ratio of any term and the sum of all the terms that follow it?

- (a) 2 (b) -2
(c) -4 (d) Cannot be determined

Question 16

In an arithmetic progression, the sum of the first 10 terms is half the sum of first 15 terms. Find the ratio of the sum of first 16 terms and first 21 terms of some AP.

- (a) 7:11 (b) 6:10
(c) 12:17 (d) 8:13

ANSWERS AVAILABLE ON:

- TELEGRAM CHANNEL: t.me/KINSHUKInstitute
- WEBSITE : WWW.KITest.IN
- KITest APP

PAST EXAMINATION QUESTIONS:

MAY 2018

Question 1

The sum to m terms of the series 1 + 11 + 11 + 1111 +Upto m terms is equal to:

- (a) $\frac{1}{81}(10^{m+1} - 9m - 10)$ (b) $\frac{1}{27}(10^{m+1} - 9m - 10)$
(c) $(10^{m+1} - 9m - 10)$ (d) None

Answer: a

Explanation:

Given series:

1+11+111+m term

$$\frac{1}{9} [9 + 99 + 999 + \dots .m \text{ term}]$$

$$\frac{1}{9} [(10 - 1) + (100 - 1) + (1000 - 1) + 1 \dots + m \text{ term}]$$

$$\frac{1}{9} \left[\frac{10 \cdot (10^m - 1)}{10 - 1} - m \right]$$

$$\frac{1}{9} \left[\frac{10^{m+1} - 10}{9} - m \right]$$

$$\frac{1}{9} \left[\frac{10 \cdot 10^{m+1} - 10 - 9m}{9} - m \right]$$

$$\frac{1}{81} (10 \cdot 10^{m+1} - 9m - 10)$$

Question 2

A person pays Rs.975 in monthly installments; each installment is less than former by Rs.5.

The amount

- (a) 26 months (b) 15 months
(c) both (a) & (b) (d) 18 months

Answer: c**Explanation:**

$$s_n = 975, a = 100, d = -5, n = ?$$

$$s_n = \frac{n}{2}(2a + (n - 1)d)$$

$$975 = \frac{n}{2}[2 \times 100 + (n - 1)(-5)]$$

$$1950 = n[200 - 5n + 5]$$

$$1950 = n[205 - 5n]$$

$$1950 = 205n - 5n^2$$

$$5n^2 - 205n + 1950 = 0$$

$$5(n^2 - 41n + 390) = 0$$

$$n^2 - 41n + 390 = 0$$

$$n^2 - 26n - 15n + 390 = 0$$

$$n(n - 26) - 15(n - 26) = 0$$

$$(n - 26)(n - 15) = 0$$

$$\text{If } n - 15 = 0 \text{ if } n - 26 = 0$$

$$n = 15 \quad n = 26$$

The entire amount will be paid in 15 months

Question 3

If the sum of n terms of an AP is $3n^2 - n$ and its common difference is 6, then its term is:

- (a) 3 (b) 2
(c) 4 (d) 1

Answer: b**Explanation:**

Let s_n be the sum of n terms of an AP with first term a and common difference d.

Since $s_n = 3n^2 - n$ and $d = 6$

$$\begin{aligned} \rightarrow S_n &= \frac{n}{2}(2a + (n - 1)d) = 3n^2 - n \\ &= \frac{n}{2}(2a + (n - 1)6) = 3n^2 - n \\ &= n(a + (n - 1)3) = 3n^2 - n \\ &= (a + 3n - 3) = 3n - 1 \\ a &= 2 \end{aligned}$$

Question 4

Insert two arithmetic means between 68 and 260.

- (a) 132, 196 (b) 130, 194
(c) 70, 258 (d) none

Answer: a**Explanation:**

Let two A.M.'S between 68 and 260 are A_1, A_2

68, $A_1, A_2, 260$

$$d = \frac{b - a}{n - 1}$$

$$d = \frac{260 - 68}{2 + 1} = \frac{192}{3} = 64$$

$$A_1 = a + d = 68 + 64 = 132$$

$$A_1 = a + 2d = 68 + 2 \times 64 = 196$$

NOV 2018

Question:1

If the p^{th} term of an A.P. is 'q' and the q^{th} term is 'p', and then its r^{th} term is

- | | |
|-------------|-------------|
| (a) $p+q-r$ | (b) $p+q+r$ |
| (c) $p-q-r$ | (d) $p-q$ |

Answer: a

Explanation:

Let 1st term of AP is 'a'

And common different is 'd'

Given $T_p = q$

$$a + (p-1)d = q \quad \text{..... (i)}$$

and $T_q = p$

$$a + (q-1)d = p$$

$$a + qd - d = p \quad \text{..... (ii)}$$

Equation (i) and equation (ii)

$$a + pd - d = q$$

$$a + qd - d = p$$

$$Pd - qd = q - p$$

$$d(p-q) = -(p-q)$$

$$d = -1$$

Putting $d = -1$ in equation (i)

$$a + p(-1) - (-1) = q$$

$$a = (p + q - 1)$$

Then, $T_r = a + (r - 1)d$

$$= p + q - 1 + (r - 1)(-1)$$

$$= p + q - 1 - r + 1$$

$$= p + q - r$$

Question 2

The 3rd term G.P. is $\frac{2}{3}$ and the 6th term is $\frac{2}{81}$, term the 1st term is

- | | |
|-------|-------------------|
| (a) 6 | (b) $\frac{1}{3}$ |
| (c) 9 | (d) 2 |

Answer: a

Explanation:

Let 1st term of G.P. is 'a' and common ratio is 'r' then

$$\text{Given } T_3 = \frac{2}{3} \text{ and } T_6 = \frac{2}{81}$$

$$ar^2 = \frac{2}{3} \quad \text{..... (i)}$$

$$ar^5 = \frac{2}{81} \quad \text{..... (ii)}$$

Eq (2) / eq (1)

$$\frac{ar^5}{ar^2} = \frac{\frac{2}{81}}{\frac{2}{3}}$$

MAY 2019**Question1**

If $y = 1+x+x^2+ \dots \infty$ then $x =$

(a) $\frac{y-1}{y}$

(b) $\frac{y+1}{y}$

(c) $\frac{y}{y+1}$

(d) $\frac{y}{y-3}$

Answer: a**Explanation:**

$$y = 1+x+x^2+ \dots \infty$$

is equivalent to GP = $\frac{a}{1-r}$

$$Y = \frac{1}{1-x}$$

$$1-x = \frac{1}{y}$$

$$1 - \frac{1}{y} = x$$

$$\frac{y-1}{y} = x$$

Question2

If $2 + 6 + 10 + 14 + 18 + \dots + x = 882$ then the value of x

(a) 78

(b) 80

(c) 82

(d) 86

Answer: c**Explanation:**

$$2 + 6 + 10 + 14 + 18 + \dots + x = 882$$

Sum of AP

$$S_n = \frac{n}{2}[2a + (n-1)d]$$

$$S_n = \frac{n}{2}[a+1]$$

$$882 = \frac{n}{2}[2 + x] \dots \dots \dots (1)$$

$$882 = \frac{n}{2} \times 2[2 + (n-1)2]$$

$$882 = n[2+2n+2]$$

$$882 = 2n^2$$

$$N^2 = 441$$

$$n = \sqrt{441}$$

$$n = 21$$

Put n in eq 1

$$882 = \frac{21}{2}[2 + x]$$

$$84 = 2 + x$$

$$X = 84 - 2 = 82$$

Question 3

In a G.P, if the fourth term is '3' then the product of first seven terms is

(a) 3^5

(b) 3^7

(c) 3^6

(d) 3^8

Answer: b

Explanation:

Let first term be a and common ratio be r .

Then according to question

$$ar^3 = 3$$

$$\text{Product of 1st 7 terms } (a)^7(r)^{21} = (ar^3)^7 = (3)^7$$

Question 4

The ratio of sum of n terms of the two AP's is $(n + 1) : (n - 1)$ then the ratio of their m^{th} terms is

- (a) $(m + 1) : 2m$ (b) $(m + 1) : (m - 1)$
 (c) $(2m - 1) : (m + 1)$ (d) $m : (m - 1)$

Answer: d**Explanation:**

$$\frac{\frac{n}{2}[2a+(n-1)d]}{\frac{n}{2}[2a'+(n-1)d']} = \frac{n+1}{n-1}$$

$$\frac{a+\frac{(n+1)d}{2}}{a'+\frac{(n-1)d'}{2}} = \frac{n+1}{n-1}$$

$$T_n^{\text{th}} = a + (n - 1) d$$

$$\frac{n-1}{1} = n - 1$$

$$n - 1 = 2n - 2$$

$$n = 2m - 2 + 1$$

$$n = 2m$$

$$n = 2m - 1$$

$$\frac{2m}{2m-2} = \frac{2m}{2(m-1)} = \frac{m}{m-1}$$

Question 5

The sum of the series

$0.5+0.55+0.555+ \dots$ to n terms is:

- a) $5n/9+5/9[1-(0.1)^n]$ b) $5n/9-5/81[1-(0.1)^n]$
 c) $5n/81 +5/81[1-(0.1)^n]$ d) $5n/9 +5/81 [1-(0.1)^n]$

Answer: b**Explanation:**

Given series $0.5 + 0.55 + 0.555 \dots$ n terms

we know that,

$$0.1 + 0.1^2 + 0.1^3 + \dots = \frac{0.1(1-0.1^n)}{0.9} = \frac{(1-0.1^n)}{9}$$

$$\rightarrow 5(0.1 + 0.11 + 0.111 + \dots)$$

$$\rightarrow 5 \left(\frac{1}{10} + \frac{11}{100} + \frac{111}{1000} + \dots \right)$$

$$\rightarrow \frac{5}{9} \left(\frac{9}{10} + \frac{99}{100} + \frac{999}{1000} + \dots \right)$$

$$\rightarrow \frac{5}{9} \left(\left(1 - \frac{1}{10}\right) + \left(1 - \frac{1}{100}\right) + \left(1 - \frac{1}{1000}\right) + \dots \right)$$

$$\rightarrow \frac{5}{9} (1 + 1 + \dots \text{ n terms}) - \left(\frac{1}{10} + \frac{1}{100} + \frac{1}{1000} + \dots \right)$$

$$\rightarrow \frac{5}{9} \left(n - \frac{(1-0.1^n)}{9} \right)$$

NOV 2019

Question 1

If $\frac{(b+c-a)}{a}$, $\frac{(c+a-b)}{b}$, $\frac{(a+b-c)}{c}$ are in AP then a, b, c are in

- a) AP
b) GP
c) HP
d) None

Answer: (c)

Explanation:

Given :

$\frac{(b+c-a)}{a}$, $\frac{(c+a-b)}{b}$, $\frac{(a+b-c)}{c}$ are in A.P.

Add 2 to each

$$\frac{(b+c-a)}{a} + 2, \frac{(c+a-b)}{b} + 2, \frac{(a+b-c)}{c} + 2$$

$$= \frac{b+c-a+2a}{a}, \frac{c+a-b+2b}{b}, \frac{a+b-c+2c}{c}$$

$$= \frac{a+b+c}{a}, \frac{a+b+c}{b}, \frac{a+b+c}{c}$$

Now, divide by a+b + c

$$= \frac{1}{a}, \frac{1}{b}, \frac{1}{c} \text{ are in A.P.}$$

We know, HP = $\frac{1}{\text{A.P.}}$

= a, b, c are in H.P.

∴ Option c i.e. H.P is the correct option,

Question 2

Sum upto infinity of series

$$\frac{1}{2} + \frac{1}{3^2} + \frac{1}{2^3} + \frac{1}{3^4} + \frac{1}{25^2} + \dots$$

- (a) 19/24
(b) 24/19
(c) 5/24
d) none

Answer: (a)

Explanation:

We know

$$S_{\infty} = \frac{a}{1-r}, r < 1$$

Here, $\frac{1}{2} + \frac{1}{3^2} + \frac{1}{2^3} + \frac{1}{3^4} + \frac{1}{25^2} + \dots$

$$\left(\frac{1}{2} + \frac{1}{3^3} + \frac{1}{2^5} + \dots \dots \infty \right) + \left(\frac{1}{2} + \frac{1}{3^3} + \frac{1}{2^5} + \dots \dots \infty \right)$$

$$\left\{ a = \frac{1}{2}, r = \frac{1}{4} < 1 \right\}; \left\{ a = \frac{1}{2}, r = \frac{1}{4}, 1 \right\}$$

$$\left(\frac{\frac{1}{2}}{1-\frac{1}{4}} \right) + \left(\frac{\frac{1}{9}}{1-\frac{1}{9}} \right)$$

$$\frac{\frac{1}{2}}{\frac{3}{4}} + \frac{\frac{1}{9}}{\frac{8}{9}}$$

$$\frac{1}{2} \times \frac{4}{3} + \frac{1}{9} \times \frac{9}{8}$$

$$\frac{2}{3} + \frac{1}{8}$$

$\frac{19}{24}$ **Question 3**Sum the series $\frac{1}{5}, \frac{1}{5^2}, \frac{1}{5^3}, \dots, \frac{1}{5^n}$

(a) $\frac{1}{4} \left[1 - \left(\frac{1}{5} \right)^n \right]$

(b) $\frac{1}{5} \left[1 - \left(\frac{1}{4} \right)^n \right]$

(c) both

(d) none

Answer: (a)**Explanation:**Series $\frac{1}{5}, \frac{1}{5^2}, \frac{1}{5^3}, \dots, \frac{1}{5^n}$ So, here $a = \frac{1}{5}, r = \frac{1}{5}, \frac{1}{5} < 1$

$$S_n = a \frac{(1-r^n)}{(1-r)}, r < 1$$

$$S_n = \frac{1}{5} \left[\frac{1 - \left(\frac{1}{5} \right)^n}{1 - \left(\frac{1}{5} \right)} \right]$$

$$S_n = \frac{1}{5} \times \frac{5}{4} \left[1 - \left(\frac{1}{5} \right)^n \right]$$

$$S_n = \frac{1}{4} \left[1 - \left(\frac{1}{5} \right)^n \right]$$

Question 4Find the no. of terms of the series 25, 5, 1, $\frac{1}{3125}$

(a) 6

(b) 7

(c) 8

(d) 9

Answer: (c)**Explanation:**

Here gives the series 25, 5, 1/5.....

Let the Total Number of Terms = n

First Term a = 25

Common ratio r = 1/5

Last Term $a_n = \frac{1}{3125}$

we have the formula

$$a_n = ar^{n-1}$$

$$\rightarrow \frac{1}{3125} = 25 \left(\frac{1}{5} \right)^{n-1}$$

$$\rightarrow \left(\frac{1}{5} \right)^5 = \left(\frac{1}{5} \right)^{n-3}$$

$$\rightarrow n - 3 = 5$$

$$\rightarrow n = 8$$

Yes, 1/3125 is the 8th term of the series.**Question 5**

If the sum of five terms of AP is 75. Find the third term of the series.

(a) 35

(b) 30

(c) 15

(d) 20

Answer: (c)**Explanation:**

We know

$$S_n = \frac{n}{2}[2a + (n-1)d]$$

$$n=5 \quad S_5 = 75$$

$$S_5 = \frac{5}{2}[2a + (5-1)d]$$

$$75 = \frac{5}{2}[2a + 4d]$$

$$15 = a + 2d \quad \text{-----Eq (1)}$$

$$T_3 = a + (3 - 1)d$$

$$T_3 = a + 2d$$

-----From Eq (1)

$$T_3 = 15$$

Question6

If the AM and GM of the two numbers is 6.5 and 6 the no's are:

(a) 3 and 2

(b) 9 and 4

(c) 81 and 16

(d) None

Answer: (b)

Explanation:

Let the two nos.be 'a' and 'b'

$$AM = \frac{a+b}{2};$$

$$GM = \sqrt{ab}$$

$$\sqrt{ab} = 6$$

$$\frac{a+b}{2} = 6.5$$

On squaring

$$ab = 36 \quad \text{----Equation (2)}$$

$$a + b = 13$$

$$a = 13 - b$$

----Equation (1)

Put Eq (1) in Eq (2)

$$b \times (13 - b) = 36$$

$$13b - b^2 = 36$$

$$b^2 - 13b + 36 = 0$$

$$b^2 - 9b - 4b + 36 = 0$$

$$b(b-9) - 4(b-9) = 0$$

$$b = 9$$

$$b = 4$$

$$a = 13 - 9$$

$$a = 13 - 4$$

$$a = 4$$

$$a = 9$$

So the two numbers are 4 and 9

Question: 7

If AM and HM for numbers are 5 and 3:2, respectively GM will be

(a) 20

(c) 16

(c) 4

(d) 5

Answer:(c)

Explanation:

We know that

$$(GM)^2 = AM \times HM$$

$$\text{Here } (GM)^2 = 5 \times 3.2$$

$$(GM)^2 = 16$$

(GM) = 4.

DEC 2020

Question 8

The 20th term of arithmetic progression whose 6th term is 38 and 10th term is 66 is _____

- (a) 136 (b) 118
(c) 178 (d) 210

Answer: a

Explanation:

Let a and d be the first term and common difference of an AP

It is given that, 6th term $a_6 = 38$ and 10th term $a_{10} = 66$.

Therefore,

$$a + 5d = 38 \dots (i)$$

$$a + 9d = 66 \dots (ii)$$

Subtracting (i) from (ii), we have

$$4d = -28$$

$$d = 7$$

Substituting in (i), we have

$$a + 5(7) = 38$$

Hence, the 20th term is 136.

Question 9

Three numbers in G.P with their sum is 130 and their product is 27,000 are _____

- (a) 90, 30, 10 (b) 10, 30, 90
(c) 10, 20, 30 (d) Both

Answer: d

Explanation:

Let the three number be $\frac{a}{r}, a, ar$

$$\frac{a}{r} + a + ar = 130$$

$$\frac{a}{r} \cdot a \cdot ar = 27000 \rightarrow a^3 = (30)^3$$

$$a = 30$$

$$a \left[\frac{1 + r + r^r}{r} \right] = 130$$

$$\frac{1 + r + r^r}{r} = \frac{13}{3}$$

$$\rightarrow 3r^r - 10r + 3$$

$$\rightarrow r=3 \text{ or } \frac{1}{3}$$

The numbers are 10, 30, and 90

Question 10

Divide 69 into 3 parts which are in A.P and are such that the product of first two parts is 460

- (a) 20, 23, 26 (b) 21, 23, 25
(c) 19, 23, 27 (d) 22, 23, 24

Answer: a

Explanation:

Let the first term of the AP be 'a'
And the common difference be 'd'
Since 69 split into 3 parts such that they form an AP.
Let the three parts be (a - d), (a) and (a + d).
Therefore,
 $(a - d) + (a) + (a + d) = 69$
 $3a = 69$
 $a = 23$
The product of two smaller parts = 460
So,
 $(a) \times (a - d) = 460$
 $23 \times (23 - d) = 460$
 $\Rightarrow 529 - 23d = 460$
 $\Rightarrow -23d = 460 - 529$
 $\Rightarrow -23d = -69$
 $\Rightarrow d = 63/23$
 $\Rightarrow d = 3$
Therefore,
The 3 parts are
 $23 - 3 = 20$;
And $23 + 3 = 26$
Hence the parts of the given AP are 20, 23, and 26

IAN 2021

Question 1

The nth term of the series 3 + 7 + 13 + 21 + 31 + is

- (a) $4n - 1$ (b) $n^2 + 2n$
(c) $n^2 + n + 1$ (d) $n^3 + 2$

Answer: c

Explanation:

$$3 + 7 + 13 + 21 + \dots + a_{n-1} + a_n \text{-----(1)}$$

$$3 + 7 + 13 + 21 + \dots + a_{n-2} + a_{n-1} + a_n \text{----- (2)}$$

$$\text{Eq 1 - Eq 2}$$

$$s-s = 3-0 + (7+3) + (13-7) + \dots + (a_{n-1} - a_{n-2} + (a_n - a_{n-1}) - a_n$$

$$0 = [3+4+6+\dots+a_{n-1}] - a_n$$

$$a_n = 3 + [4 + 6 + 8 + \dots + a_{n-1}] \text{----- (3)}$$

Now $4+6+8+\dots + a_{n-1}$ are in A.P.

First term $a = 4$, Common difference $d = 2$

$$\text{Sum of n term of AP} = \frac{n}{2} [2a + (n - 1)d]$$

$$= 4 + 6 + 8 + \dots + a_{n-1} = \frac{n-1}{2} [2 \times 4 + (n - 1 - 1) \times 2]$$

$$= \left(\frac{n-1}{2}\right) [8 + 2n - 4]$$

$$= \frac{n-1}{2} (2n + 4)$$

$$= (4+6+8+\dots+a_{n-1}) = (n-1)(n+2)$$

By Eq 3

$$a_n = 3 + [4+6+8+\dots + a_{n-1}]$$

$$a_n = 3 + (n-1)(n+2)$$

$$= 3 + n^2 - n + 2n - 2$$

$$a_n = n^2 + n + 1$$

Question 2

The number of integers from 1 to 100 which are neither divisible by 3, nor by 5 nor by 7, is

- (a) 67 (b) 55
(c) 45 (d) 33

Answer: c

Explanation:

Total No. – 100

divide by 3 = $100/3 = 33$

divide by 5 = $100/5 = 20$

divide by 7 = $100/7 = 14$

$$= 33+20+14 = 67$$

$$3 \& 5 = 100/15 = 6$$

$$5 \& 7 = 100/35 = 2$$

$$7 \& 3 = 100/21 = 4$$

$$= 6+2+4 = 12$$

$$= 67-12 = 55$$

Total Divisible by 3,5&7 are 55

Total -divisible = not divisible

$$100-55 = 45$$

Question 3

In a geometric progression, the 3rd and 6th terms are respectively, 1 and $-1/8$. The first term

(a) and common ratio are respectively.

- (a) 4 and $\frac{1}{2}$ (b) 4 and $\frac{-1}{4}$
(c) 4 and $\frac{-1}{2}$ (d) 4 and $\frac{1}{4}$

Answer: c

Explanation:

By option c

$$a=4 \& r = -1/2$$

Check 3rd GP

$$1/2 \times 4 = 2 \text{ (4 time equals to) } = 1$$

checking 6th GP

$$1/2 \times 4 = 2 \text{ (7 time equals to) } = -0.125$$

$$= -1/8 = 0.125$$

JULY 2021

Question 1

The number of term of the series: $5 + 7 + 9 + \dots$ Must be taken so that the sum may be 480

- (a) 20 (b) 10
(c) 15 (d) 25

Answer: Options (a)**Explanation:**

$$5 + 7 + 9 \dots\dots$$

$$a = 5, d = 2, s = 480$$

$$S = \frac{n}{2} (2a + n - 1) d$$

$$480 = \frac{n}{2} (2(5) + (n - 1)(2))$$

$$480 = \frac{n}{2} (10 + 2n - 2)$$

$$480 = n(2n + 8)$$

$$480 = 2n^2 + 8n$$

$$2n^2 + 8n - 480$$

$$2(n^2 + 4n - 480)$$

$$\Rightarrow n^2 + 4n - 480$$

$$n^2 + 20n + 24n - 480$$

$$n(n - 20) + 24(n - 20)$$

$$n + 24 = 0$$

$$n - 20 = 0$$

$$n = -24$$

$$n = 20$$

Question 2

The fifth term of an AP of n terms, whose sum is $n^2 - 2n$, is

(a) 5

(b) 7

(c) 8

(d) 15

Answer: Options (b)**Explanation:-**

Given: Sum of n terms of an AP = $n^2 - 2n$.

To find: The fifth term =?

Sum of 'n' terms of an AP = $n^2 - 2n$

∴ Sum of 1st 5 terms

$$\Rightarrow S_5 = 5^2 - 2 \cdot (5)$$

$$\Rightarrow 25 - 10 = 15$$

Similarly,

Now, sum of first 4 terms

$$S_4 = 4^2 - 2 \cdot (4)$$

$$= 16 - 8 = 8$$

Similarly,

Now, sum of first 4 terms

$$S_4 = 4^2 - 2 \cdot (4)$$

$$= 16 - 8 = 8$$

∴ The 5th term of an AP''

$$\Rightarrow t_5 = S_5 - S_4 \quad \dots, (\text{Using } T_n = S_n - S_{n-1})$$

$$= 15 - 8$$

$$= 7$$

So, option 2 is correct.

Question 3

The sum of three numbers in a geometric progression is 28. When 7, 2 and 1 are subtracted from the first, second and third numbers respectively, then the resulting numbers are in

arithmetic progression. What is the sum of squares of the original three numbers?

- (a) 510 (b) 456
(c) 400 (d) 336

Answer: Options (d)

DEC 2021

Question 1

If the sum and product of three number in G.P. are 7 and 8 respectively, then 4th term of the series is

- (a) 6 (b) 4
(c) 8 (d) 16

Answer: d

Explanation:-

$$t_n = ar^{n-1}$$

Let the three terms of G.P. be a/r , a and ar respectively.

Since the product is 8, we have:

$$\frac{a}{r} \times a \times ar = 8$$

$$a^3 = 8$$

$$A = (8)^{1/3} = 2$$

Also, it is given that $\frac{a}{r} + a + ar = 7$

$$\frac{a + ar + ar^2}{r} = 7$$

$$a + ar + ar^2 = 7r$$

Putting the value of $a=2$ above, we get:

$$2 + 2r + 2r^2 = 7r$$

$$2r^2 + 2r - 7r + 2 = 0$$

$$2r^2 - 5r + 2 = 0$$

$$2r^2 - 4r - r + 2 = 0$$

$$2r(r-2) - (r-2) = 0$$

$$(2r-1)(r-2) = 0$$

So, either $2r-1 = 0$ - $r = \frac{1}{2}$

Or $r-2 = 0$ - $r = 2$

Taking $r = 1/2$, we have $t_4 = 2 \left[\frac{1}{2} \right]^3 = 0.25$

Taking $r = 2$, we have $t_4 = 2 (2)^3 = 16$

Since 0.25 is not in the options, option(d) is the answer.

Question 2

The sum of series 7+14+21+.... To 17th term is:

- (a) 1071 (b) 971
(c) 1171 (d) 1271

Answer: a

Explanation:-

Clearly, this is an AP with $a=7$; $d=14-7=7$; $n=17$

$$S_n = \frac{n}{2} \{2a + (n-1)d\}$$

$$S_{17} = \frac{17}{2} \{(2 \times 7) + 17 - 1\} = 1,071$$

Question 3

The sum of first n terms an AP is $3n^2 + 5n$. The series is:

(a) 8, 14, 20, 26,

(b) 8, 22, 42, 68, ...

(c) 22, 68, 114,

(d) 8, 14, 28, 44, ...

Answer:**Explanation:-**

$$S_1 = t_1 = a = 3(1)^2 + 5(1) = 3 + 5 = 8$$

$$S_2 = 3(2)^2 + 5(2) = 22$$

$$t_2 = 22 - 8 = 14$$

$$d = t_2 - t_1 = 14 - 8 = 6$$

Question 4

The largest value of n which $\frac{1}{2} + \frac{1}{2^2} + \dots + \frac{1}{2^n} < 0.998$ is

(a) 9

(b) 6

(c) 7

(d) 8

Answer: d**Explanation:-**

The given series is a GP with $a = \frac{1}{2}$; $r = \frac{1}{2}$

$$\text{Since } r < 1, S_n = a \left[\frac{1-r^n}{1-r} \right]$$

Try the options,

Option (a) - 9

If $n = 9$

$$S_9 = \frac{1}{2} \left(\frac{1-(1/2)^9}{1-(1/2)} \right) = 0.998046875$$

Option (b) - 6

If $n = 6$

$$S_6 = \frac{1}{2} \left(\frac{1-(1/2)^6}{1-(1/2)} \right) = 0.984375$$

Option (c) - 7

If $n = 6$

$$S_7 = \frac{1}{2} \left(\frac{1-(1/2)^7}{1-(1/2)} \right) = 0.9921875$$

Option (d) - 8

If $n = 8$

$$S_8 = \frac{1}{2} \left(\frac{1-(1/2)^8}{1-(1/2)} \right) = 0.99609375$$

Clearly, option (d) is the answer as it is the largest value for which the sum of the series is less than 0.998.

JUNE 2022**Question 1**

The n^{th} term of the series 9,7,5,..... and 15,12,9,.....are same. Find the n^{th} term?

- (a) 7 (b) 8
(c) 9 (d) 10

Answer: Options (a)**Explanation:**

Given Series

9, 7, 5..... n term

$$a = 9, d = 7 - 9 = -2, n = n$$

$$T_n = a + (n - 1) d$$

$$T_n = 9 + (n - 1)(-2)$$

$$= 9 - 2n + 2$$

$$= 11 - 2n$$

and other series

= 15, 12, 9.....n term

$$a = 15, d = 12 - 15 = -3, n = n$$

$$T_n = a + (n - 1) d$$

$$= 15 + (n - 1)(-3)$$

$$= 15 - 3n + 3 = 18 - 3n$$

$$= 11 - 2n$$

Given n^{th} term of both series are equal

$$\text{then } 11 - 2n = 18 - 3n$$

$$3n - 2n = 18 - 11$$

$$n = 7$$

Question 2

Then sun of first 8 terms of a G.P is five times the sum of the first 4 terms. Find the common ratio?

- (a) $\frac{+}{-}\sqrt{2}$ (b) 16
(c) $\frac{+}{-}\sqrt{20}$ (d) 4

Answer: Options (a)**Explanation:**Let 1st term of G.P = a

Common Ratio (r) = r

Given

$$S_8 = 5 S_4$$

$$\frac{a(r^8 - 1)}{r - 1} = 5 \frac{a(r^4 - 1)}{r - 1}$$

$$r^8 - 1 = 5(r^4 - 1)$$

$$(r^4)^2 - (1)^2 = 5(r^4 - 1)$$

$$r^4 + 1 = 5$$

$$r^4 = 4$$

$$(r^2)^2 = (2)^2 \Rightarrow r = \pm \sqrt{2}$$

Question 3

A person pays ₹ 975 in monthly instalments; each instalment is less then former by ₹ 5. The amount of 1st instalments is ₹100. In what time will the entire amount be paid?

- (a) 26 months (b) 15 months
(c) Both (a) and (b) (d) 18 months

Answer: Options (a)**Explanation:**

Given $S_n = 975$, 1st Installment $(a) = 100$, $d = -5$

Then series is

100, $(100-5)$, $(100-5-5)$, ..n term

100, 95, 90, n term

$$S_n = \frac{n}{2} [2a + (n-1)d]$$

$$975 = \frac{n}{2} [2 \times 100 + (n-1)(-5)]$$

$$975 \times 2 = n[200 - 5n + 5]$$

$$1950 = n(205 - 5n)$$

$$1950 = 205n - 5n^2$$

$$5n^2 - 205n + 1950 = 0$$

$$\text{or } n^2 - 41n + 390 = 0$$

Solving this we get $n = 15$ or $n = 26$ (not valid)

DEC 2022**Question 1**

If pth term of an AP is q and its qth term is p, then what will be the value of $(p+q)$ th term?

a) 0

b) 1

c) $p+q-1$

d) $2(p+q-1)$

Answer: Options (a)**Explanation:-**

In the given AP, let the first be a and the common difference be d.

Then, $T_n = a + (n-1)d$

$$\rightarrow T_p = a + (p-1)d = q \quad (1)$$

$$\rightarrow T_q = a + (q-1)d = p \quad (2)$$

On subtracting (i) from (ii), we get:

$$(q-p)d = (p-q)$$

$$\rightarrow d = -1$$

Putting $d = -1$ in (1), we get

$$a = (p+q-1)$$

Thus, $a = (p+q-1)$ and $d = -1$

$$\text{Now, } T_{p+q} = a + (p+q-1)d$$

$$= (p+q-1) + (p+q-1)(-1)$$

$$= (p+q-1) - (p+q-1) = 0$$

Question 2

In a G.P. 5th term is 27 and 8th term is 729. Find its 11th term.

a) 729

b) 6561

c) 2187

d) 19683

Answer: Options (d)**Explanation:-**

Given, $a_5 = 27$ and $a_8 = 729$.

$$\Rightarrow ar^4 = 27 \text{ and } ar^7 = 729$$

On dividing we get,

$$r^3 = 27 \Rightarrow r = 3 \Rightarrow r = 3$$

$$\Rightarrow a = 27 / (3^4) = 1/3$$

$$\Rightarrow a_{11} = ar^{10} = (1/3) (3^{10}) = 3939 = 19683.$$

Question 3

Find the missing number in the following series?

3, 5, 5, 19, 7, 41, 9, ?, 11, 109

a) 71

b) 61

c) 69

d) 79

Answer: Options (a)

Explanation:-

First series: 3, 5, 7, 9

Second series: 5, 19, 41, ?

Difference of Second series are 14, 22, 30 etc

Next term is 41+30 i.e equal to 71

Question 4

Find the next number in the given sequence?

11, 17, 39, 85, ?, 281, 447

a) 133

b) 143

c) 153

d) 163

Answer: Options (d)

Explanation:-

11

$$11 + (3^2 - 3) = 17$$

$$17 + (5^2 - 3) = 39$$

$$39 + (7^2 - 3) = 85$$

$$85 + (9^2 - 3) = 163$$

Hence, the next number in the given sequence is 163. Hence, option 4 is the correct answer.

CHAPTER - 7 SETS, RELATIONS AND FUNCTIONS

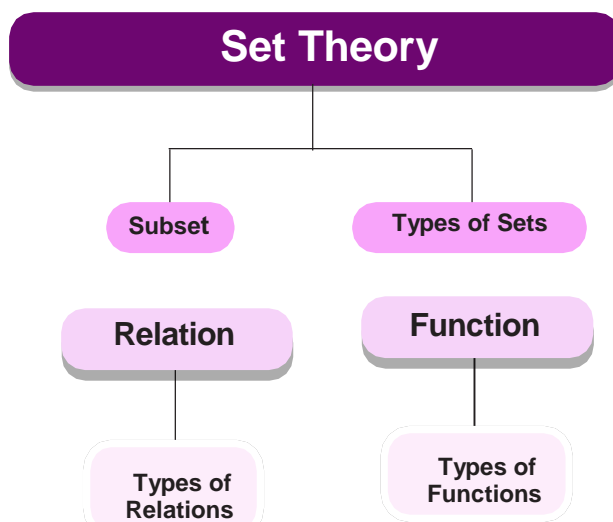

SET	<p>A set is defined to be a collection of well – defined distinct objects. This collection may be listed or described. Each object is called an element of the set. We usually denote sets by capital letters and their elements by small letters</p> <table border="1" style="width: 100%; border-collapse: collapse;"> <tr> <td style="background-color: #8B4513; color: white; text-align: center;">Singleton set</td> <td>A set containing one element is called singleton</td> </tr> <tr> <td style="background-color: #8B4513; color: white; text-align: center;">Equal set</td> <td>Two sets A & B are said to be equal, written as $A = B$ if every element of A is in B and every element of B is in A.</td> </tr> </table>	Singleton set	A set containing one element is called singleton	Equal set	Two sets A & B are said to be equal, written as $A = B$ if every element of A is in B and every element of B is in A.
Singleton set	A set containing one element is called singleton				
Equal set	Two sets A & B are said to be equal, written as $A = B$ if every element of A is in B and every element of B is in A.				
VENN DIAGRAMS	<p>A venn diagram is a diagram that shows all possible logical relation between a fine collections of different sets. These diagram depict elements as point in the plane, and sets as region inside closed curves.</p> <div style="text-align: center;"> </div>				
EQUIVALENT SET	<p>Two finite sets A & B are said to be equivalent if $n(A) = n(B)$.</p>				

POWER SET	<p>The collection of all possible subsets of a given set A is called the power set of A, to be denoted by $P(A)$.</p> <ol style="list-style-type: none"> 1. A set containing n elements has 2^n subsets. 2. A set containing n elements has 2^{n-1} proper subsets 				
PRODUCT SETS	<table border="1"> <tr> <td style="background-color: #8B4513; color: white;">Ordered Pair</td> <td>Two elements a and b, listed in a specific pair, denoted by (a, b).</td> </tr> <tr> <td style="background-color: #8B4513; color: white;">Cartesian Product of sets</td> <td>If A and B are two non-empty sets, then the set of all ordered pairs (a, b) such that a belongs to A and b belongs to B, is called the Cartesian product of A and B, to be denoted by $A \times B$. Thus, $A \times B = \{(a, b) : a \in A \text{ and } b \in B\}$ If</td> </tr> </table>	Ordered Pair	Two elements a and b, listed in a specific pair, denoted by (a, b).	Cartesian Product of sets	If A and B are two non-empty sets, then the set of all ordered pairs (a, b) such that a belongs to A and b belongs to B, is called the Cartesian product of A and B, to be denoted by $A \times B$. Thus, $A \times B = \{(a, b) : a \in A \text{ and } b \in B\}$ If
Ordered Pair	Two elements a and b, listed in a specific pair, denoted by (a, b).				
Cartesian Product of sets	If A and B are two non-empty sets, then the set of all ordered pairs (a, b) such that a belongs to A and b belongs to B, is called the Cartesian product of A and B, to be denoted by $A \times B$. Thus, $A \times B = \{(a, b) : a \in A \text{ and } b \in B\}$ If				
RELATION AND FUNCTION	<p>Any subset of the product set X,Y is said to define a relation from X to Y and any relation from X to Y in which no two different ordered pairs have the same first elements is called a function.</p> <p>Let A and B be two non-empty sets. Then, a rule or a correspondence f which associates to each element x of A, a unique element, denoted by $f(x)$ of B is called a function or mapping from A to B and we write $f : A \rightarrow B$</p>				
DOMAIN & RANGE OF A FUNCTION	<p>Let $f : A \rightarrow B$ then, A is called the domain of f, while B is called the co-domain of f.</p> <p>The set $f(A) = \{f(x) : x \in A\}$ is called the range of f.</p>				

VARIOUS TYPES OF FUNCTION

IDENTITY FUNCTION

• Let A be a non-empty set. Then, the function I defined by $I : A \rightarrow A : I(x) = x$ for all $x \in A$ is called an identity function on A

EQUAL FUNCTION

• Two functions f and g are said to be equal, written as $f = g$ if they have the same domain and they satisfy the condition $f(x) = g(x)$, for all x.

INVERSE FUNCTION

• Let f be a one-one onto function from A to B. Let y be an arbitrary element of B. Then f being onto, there exists an element x in A such that $f(x) = y$. A function is invertible if and only if f is one-one onto.

ONE -ONE FUNCTION

• Let $f : A \rightarrow B$. If different elements in A have different images in B, then f is said to be a one-one or an injective function or mapping

ONTO or SURJECTIVE FUNCTION

• Let $f : A \rightarrow B$. If every element in B has at least one pre- image in A, then f is said to be an onto function. If f is onto, then corresponding to each $y \in B$, we must be able to find at least one element $x \in A$ such that $y = f(x)$ Clearly, f is onto if and only if range of $f = B$

BIJECTION FUNCTION

• A one-one and onto function is said to be bijective

Different types of relations

Let $S = \{a, b, c, \dots\}$ be any set then the relation R is a subset of the product set $S \times S$

i) If R contains all ordered pairs of the form (a, a) in $S \times S$, then R is called reflexive. In a reflexive relation 'a' is related to itself.

For example, 'Is equal to' is a reflexive relation for $a = a$ is true.

ii) If $(a, b) \in R \Rightarrow (b, a) \in R$ for every $a, b \in S$ then R is called symmetric

For Example, $a = b \Rightarrow b = a$. Hence the relation 'is equal to' is a symmetric relation.

iii) If $(a, b) \in R$ and $(b, c) \in R \Rightarrow (a, c) \in R$ for every $a, b, c \in S$ then R is called transitive.

For Example $a = b, b = c, a = c$. Hence the relation 'is equal to' is a transitive relation.

A relation which is reflexive, symmetric and transitive is called an *equivalence relation* or simply equivalence. 'is equal to' is an equivalence relation.

Similarly, the relation "is parallel to" on the set S of all straight lines in a plane is an equivalence relation.

Domain & Range of a relation

If R is a relation from A to B, then the set of all first co- ordinates of elements of R is called the domain of R, while the set of all second co-ordinates of elements of R is called the range of R.

**Question1**

Which of the following statements is used to create an empty set?

- (a) $\{\}$ (b) Set $()$
 (c) $[\]$ (d) $()$

Answer: b

Explanation:

$\{\}$ Creates a dictionary not a set. Only set $()$ creates an empty set.

For more Info Visit - www.KITest.in

Question 2

What is the output of the following piece of code when executed in the python shell?

- (a) { 2, 3} (b) Error, duplicate item present in list
 (c) Error, no method called intersection update for set data type (d) { 1, 4, 5 }

Answer: a

Explanation:

The method intersection update returns a set which is an intersection of both the sets.

Question 3

Which of the following lines code will result is an error?

- (a) {abs} (b) s = {4, 'abc', (1,2) }
 (c) { 1, 2, 5, 9} (d) {1, 5, 7, 9, 11}

Answer: d

Explanation:

The line: s={san} will result is an error because 'san' is not defined. The line s={abs} does not result in an error because abs is a built – in function. The other sets shown do not result in an error because all the items are hashable.

Question 4

What is the output of the code shown below?

S=set ([1, 2, 3,])

S, union ([4, 5])

S|([4, 5])

- (a) {1, 2, 3, 4, 5} {1, 2, 3, 4, 5} (b) Error {1, 2, 3, 4, 5}
 (c) {1, 2, 3, 4, 5} Error (d) Error

Answer: c

Explanation:

The first function in the code shown above returns the set { 1, 2, 3, 4, 5}. This is because the method of the function union allows any alterable. However, the second function results in an error because f unsupported data type that is list and set.

Question 5

What is the output of the line of code shown below, if s1 = {1, 2, 3} Is S1 subset ?

- (a) True (b) Error
 (c) No output (d) Proposition

Answer: a

Explanation:

Every set is a subset of itself and hence the output of this line of code is true.

Question 6

A ____ is an ordered collection of objects.

- (a) Relation (b) Function
 (c) Set (d) Proposition

Answer: c

Explanation:

A set is an ordered collection of objects.

Question 7

The set of odd positive integers less than 10 can be expressed by _____

- (a) {1, 2, 3} (b) {1, 3, 5, 7, 9}
(c) {1, 2, 5, 9} (d) {1, 5, 7, 9, 11}

Answer: b

Explanation:

Odd numbers less than 10 is {1, 3, 5, 7, 9}.

Question 8

Power set of empty set has exactly _____ subset.

- (a) 1 (b) 2
(c) 0 (d) 3

Answer: a

Explanation:

Power set of null set has exactly one subset which is empty set.

Question 9

What is the Cartesian product of $A = \{1, 2\}$ and $B = \{a, b\}$?

- (a) {(1, a), (1, b), (2, a), (b, b)} (b) {(1, 1), (2, 2), (a, a), (b, b)}
(c) {(1, a), (2, a), (1, b), (2, b)} (d) {(1, 1), (a, a), (2, a), (1, b)}

Answer: c

Explanation:

A subset R of the Cartesian Product $A \times B$ is a relation from the set A to the set B.

Question 10

The Cartesian product $B \times A$ is equal to the Cartesian product $A \times B$. Is it True or False?

- (a) True (b) False
(c) partial true (d) not sure

Answer: b

Explanation:

Let $A = \{1, 2\}$ and $B = \{a, b\}$. The Cartesian product $A \times B = \{(1, a), (1, b), (2, a), (2, b)\}$ and the Cartesian product $B \times A = \{(a, 1), (a, 2), (b, 1), (b, 2)\}$. This is not equal to $A \times B$

Question 11

What is the cardinality of the set of odd positive integers less than 10?

- (a) 10 (b) 5
(c) 3 (d) 20

Answer: b

Explanation:

Set S of odd positive an odd integer less than 10 is {1, 3, 5, 7, 9}. Then Cardinality of set S = |S| which is 5.

Question 12

Which of the following two sets are equal?

- (a) $A = \{1, 2\}$ and $B = \{1\}$ (b) $A = \{1, 2\}$ and $B = \{1, 2, 3\}$

(c) $A = \{1, 2, 3\}$ and $B = \{2, 1, 3\}$ (d) $A = \{1, 2, 4\}$ and $B = \{1, 2, 3\}$ **Answer: c****Explanation:**

Two set are equal if and only if they have the same elements.

Question13**The set of positive integers is _____ -**

(a) Infinite

(b) Finite

(c) Subset

(d) Empty

Answer: a**Explanation:**

The set of positive integers is not finite

Question 14**What is the Cardinality of the power set of the set $\{0, 1, 2\}$.**

(a) 8

(b) 6

(c) 7

(d) 9

Answer: a**Explanation:**Power set $P(\{0, 1, 2\})$ is the set of all subsets of $\{0, 1, 2\}$. Hence, $P(\{0, 1, 2\}) = \{\text{null}, \{0\}, \{1\}, \{2\}, \{0, 1\}, \{0, 2\}, \{0, 1, 2\}\}$.**Question15****The members of the set $S = \{x|x \text{ is the square of an integer and } x < 100\}$ is _____**(a) $\{0, 2, 4, 5, 9, 58, 49, 56, 99, 12\}$ (b) $\{0, 1, 4, 9, 16, 25, 36, 49, 64, 81\}$ (c) $\{1, 4, 9, 16, 25, 36, 64, 81, 85, 99\}$ (d) $\{0, 1, 4, 9, 16, 25, 36, 49, 64, 121\}$ **Answer: b****Explanation:**

The set S consist of the square of an integer less than 10.

Question16**Let the set A is the $\{1, 2, 3\}$ and B is $\{2, 3, 4\}$. Then number of elements in $A \cup B$ is**

(a) 4

(b) 5

(c) 6

(d) 7

Answer: a**Explanation:** $A \cup B$ is $\{1, 2, 3, 4\}$ **Question 17****Let the set A is $\{1, 2, 3\}$ and B is $\{2, 3, 4\}$. Then number of elements in $A \cap B$ is**

(a) 1

(b) 2

(c) 3

(d) 4

Answer: b**Explanation:** $A \cap B$ is $\{2, 3\}$ **Question 18****Let the set A is $\{1, 2, 3\}$ and B is $\{2, 3, 4\}$. Then the set $A - B$ is**(a) $\{1, -4\}$ (b) $\{1, 2, 3\}$

(C) {1}

(d) {2, 3}

Answer: c**Explanation:**In $A - B$ the common elements get cancelled.**Question 19****In which of the following sets $A - B$ is equal to $B - A$** (a) $A = \{1, 2, 3\}$, $B = \{2, 3, 4\}$ (b) $A = \{1, 2, 3\}$, $B = \{1, 2, 3, 4\}$ (C) $A = \{1, 2, 3\}$, $B = \{2, 3, 1\}$ (d) $A = \{1, 2, 3, 4, 5, 6\}$, $B = \{2, 3, 4, 5, 1\}$ **Answer: c****Explanation:** $A - B = B - A = \text{Empty set.}$ **Question 20****Let A be set of all prime numbers; B be the set of all even prime numbers. C be the set of all odd prime numbers, then which of the following is true?**(a) $A = B \cup C$ (b) B is a single on set(c) $A = C \cup \{2\}$

(d) All of the mentioned

Answer: d**Explanation:**

2 is the only even prime number.

Question 21**If A has 4 elements B has 8 elements, then the minimum and maximum number of elements in $A \cup B$ are respectively**

(a) 4, 8

(b) 8, 12

(C) 4, 12

(d) None of the mentioned

Answer: b**Explanation:**

Minimum would be when 4 elements are same as in 8, maximum would be when all are distinct.

Question 22**If A is $\{\{\Phi\}, \{\Phi, \{\Phi\}\}$, then the power set of A has how many elements?**

(a) 2

(b) 4

(c) 6

(d) 8

Answer: b**Explanation:**The set A has got 2 elements so $n(P(A)) = 4$.**Question 23****Two sets A and B contains a and b elements respectively. If power set of A contains 16 more elements than that of B , value of ' b ' and ' a ' are respectively**

(a) 5, 4

(b) 6, 7

(c) 2, 3

(d) None of the mentioned

Answer: a**Explanation:** $2^a - 2^b = 16$, hence $a=5$, $b=4$

Question 24

Let A be {1, 2, 3, 4}, U be set of all natural numbers, then $U - A'$ (complement of A) is given by set.

- (a) {1, 2, 3, 4, 5, 6,} (b) {5, 6, 7, 8, 9,}
 (c) {1, 2, 3, 4} (d) All of the mentioned

Answer: c

Explanation:

$$U - A' = A.$$

Question 25

Which sets are not empty?

- (a) {x:x is a even prime greater than 3} (b) {x:x is a multiple of 2 and is odd}
 (c) {x:x is an even number and x+3 is even} (d) {x:x is a prime number is less than 5 and is odd}

Answer: d

Explanation:

Because the set is {3}

Question 26

If A, B and C are any three sets, then $A - (B \cap C)$ is equal to

- (a) $(A - B) \cup (A - C)$ (b) $(A - B) \cap (A - C)$
 (c) $(A - B) \cup C$ (d) None

Answer: a

Explanation:

From De Morgan's Law, $A - (B \cap C) = (A - B) \cup (A - C)$

Question 27

Which of the following is the empty set?

- (a) {x:x is a real number and $x^2 - 1 = 0$ } (b) {x:x is a real number and $x^2 + 1 = 0$ }
 (c) {x : x is a real number and $x^2 - 9 = 0$ } (d) {x : x is a real number and $x^2 = x + 2$ }

Answer: d

Explanation:

Since $x^2 - 1 = 0$, given $x^2 = -1$

$$x = \pm 1$$

\therefore No value of x is possible

Question 28

If a set A has n elements, then the total number of subsets of A is

- (a) n (b) n^2
 (c) 2^n (d) 2n

Answer: c

Explanation:

Number of subsets of A = $n_{c_0} + n_{c_1} + \dots + n_{c_n} = 2^n$

Question 29

If A and B are any two sets, then $A \cup (A \cap B)$ is equal to

- (a) A (b) B
 (c) A^c (d) B^c

Answer: a

Explanation:

$$A \cap B \subseteq A$$

$$\text{Hence } A \cup (A \cap B) = A$$

Question 30

If two sets A and B are having 99 elements in common, then the number of elements common to each of the sets $A \times B$ and $B \times A$ are

- (a) 2^{99} (b) 99^2
 (c) 100 (d) 18

Answer: b**Explanation:**

$$n((A \times B) \cap (B \times A))$$

$$= n((A \cap B) \times (B \cap A)) = n(A \cap B) \cdot n(B \cap A)$$

$$= n(A \cap B) \cdot n(A \cap B) = (99)(99) = 99^2$$

Question 31

If $A = \{x : x \text{ is a multiple of } 4\}$ and $B = \{x : x \text{ is a multiple of } 6\}$ then $A \cap B$ consists of all multiples of?

- (a) 16 (b) 12
 (c) 8 (d) 4

Answer: b**Explanation:**

$$A = \{4, 8, 12, 16, 20, 24, \dots\}$$

$$B = \{6, 12, 18, 24, 30, \dots\} \setminus A \cap B = \{12, 24, \dots\}$$

$$= \{x : x \text{ is a multiple of } 12\}.$$

Question 32

If $A = \{1, 2, 3, 4, 5\}$, $B = \{2, 4, 6\}$, $C = \{3, 4, 6\}$, Then $(A \cup B) \cap C$ is

- (a) $\{3, 4, 6\}$ (b) $\{1, 2, 3\}$
 (c) $\{1, 4, 3\}$ (d) None of these

Answer: a**Explanation:**

$$A \cup B = \{1, 2, 3, 4, 5, 6\} \setminus (A \cup B) \cap C = \{3, 4, 6\}$$

Question 33

If $n(A) = 4$, $n(B) = 3$, $n(A \times B \times C) = 24$, then $n(C) =$

- (a) 288 (b) 1
 (c) 2 (d) 17

Answer: c**Explanation:**

$$n(A) = 4, n(B) = 3 \Rightarrow n(A) \times n(B) \times n(C) = n(A \times B \times C) \Rightarrow 4 \times 3 \times n(C) = 24$$

$$n(C) = \frac{24}{12} = 2$$

Question 34

If $A = \{2, 3, 5\}$, $B = \{2, 5, 6\}$, then $(A - B) \times (A \cap B)$ is

- (a) $\{(3, 2), (3, 3), (3, 5)\}$ (b) $\{(3, 2), (3, 5), (3, 6)\}$

(c) $\{(3, 2), (3, 5)\}$

(d) None of these

Answer: c**Explanation:**

$$A - B = \{3\}, A \cap B = \{2, 5\}$$

$$(A - B) \times (A \cap B) = \{(3, 2); (3, 5)\}$$

Question 35**The set of intelligent students in a class is [AMU 1998]**

(a) A null set

(b) A singleton set

(c) A finite set

(d) Not a well definite collection

Answer: d**Explanation:**

Since, intelligence is not defined for students in a class i.e. Not a well defined collection.

Question 36**If A and B be any two sets, then $(A \cap B)'$ is equal to**(a) $A' \cap B'$ (b) $A' \cup B'$ (c) $A \cap B$ (d) $A \cup B$ **Answer: b****Explanation:**From De' Morgan's Law, $(A \cap B)' = A' \cup B'$ **Question 37****In a class of 100 students, 55 students have passed in Mathematics and 67 students have passed in physics. Then the number of students who have passed in Physics only is**

(a) 22

(b) 33

(c) 10

(d) 45

Answer: d**Explanation:**

$$n(M) = 55, n(P) = 67, n(M \cup P) = 100 \text{ Now,}$$

$$n(M \cup P) = n(M) + n(P) - n(M \cap P)$$

$$100 = 55 + 67 - n(M \cap P) \Rightarrow n(M \cap P) = 122 - 100 = 22$$

$$\text{Now } n(P \text{ only}) = n(P) - n(M \cap P) = 67 - 22 = 45$$

Question 38**20 teachers of a school either teach mathematics or physics. 12 of them teach mathematics while 4 teach both the subjects. Then the number of teachers teaching physics only is**

(a) 12

(b) 8

(c) 16

(d) None of these

Answer: a**Explanation:**

$$\text{Let } n(P) = \text{Number of teachers in Physics. } n(M)$$

$$= \text{Number of teachers in Math's } n(P \cup M) = n(P) + n(M) - n(P \cap M)$$

$$20 = n(P) + 12 - 4$$

$$= n(P) = 12$$

Question 39

In a battle 70% of the combatants lost one eye, 80% an ear, 75% an arm, 85% a leg, x% lost all the four limbs. The maximum value of x is

- (a) 10 (b) 12
(c) 15 (d) None of these

Answer: a

Explanation:

Minimum value of $1+ba > 0$
 $= 100 - 90 = 10$

Question 40

If A and B are not disjoint sets, then $n(A \cup B)$ is equal to? [Kerala (Eng.) 2001]

- (a) $n(A)+n(B)$ (b) $n(A)+n(B)-n(A \cap B)$
(c) $n(A)+n(B)+n(A \cap B)$ (d) $n(A)n(B)n(A)-n(B)$

Answer: b

Explanation:

$n(A \cup B) = n(A) + n(B) - n(A \cap B)$

Question 41

Let A and B be two sets such that $n(A)=0.16$, $n(B)=0.14$, $n(A \cup B)=0.25$. Then $n(A \cap B)$ is equal to

- (a) 0.3 (b) 0.5
(c) 0.05 (d) None of these

Answer: c

Explanation:

$n(A \cup B) = n(A) + n(B) - n(A \cap B)$
 $0.25 = 0.16 + 0.14 - n(A \cap B)$
 $n(A \cap B) = 0.30 - 0.25 = 0.05$

Question 42

Let A and B be two sets then $(A \cup B)' \cup (A' \cap B)$ is equal to

- (a) A' (b) A
(c) B' (d) None of these

Answer: a

Explanation:

From Venn-Euler's Diagram
 $\therefore (A \cup B)' \cup (A' \cap B) = A'$

Question 43

If A and B are two sets then $(A - B) \cup (B - A) \cup (A \cap B)$ is equal to

- (a) $A \cup B$ (b) $A \cap B$
(c) A (d) B'

Answer: a

Explanation:

From Venn-Euler's diagram
 $\therefore (A - B) \cup (B - A) \cup (A \cap B)$

Question: 44

The shaded region in the given figure is:

For more Info Visit - www.KITest.in

(a) $A \cap (B \cup C)$

(b) $A \cup (B \cap C)$

(c) $A \cap (B - C)$

(d) $A - (B \cup C)$

Answer: d**Explanation:**From Venn-Euler's diagram, $A - (B \cup C)$ **Question45****If A and B are two sets, then $A \cup B = A \cap B$**

(a) $A \times B$

(b) $B + A$

(c) $A = B$

(d) None of these

Answer: c**Explanation:**Let $X \in A \rightarrow X \in A \cup B$, [$\therefore A \subseteq A \cup B$] $= X \in A \cap B$, [$\therefore A \cup B = A \cap B$] $= X \in A$ and $X \in B$ $P \times \in B, \setminus A \subseteq B$ Similarly $X \in B$ $= X \in A \setminus B \subseteq A$ Now $A \subseteq B, B \subseteq A$ $= A = B$ **Question 46****The number of non-empty subsets of the set {1, 2, 3, 4} is**

(a) 15

(b) 14

(c) 16

(d) 17

Answer: a**Explanation:**The number of non - empty subsets = $2^n - 1$

$2^4 - 1 = 16 - 1 = 15$

Question47**Which set is the subset of all given sets**

(a) {1, 2, 3, 4,}

(b) {1}

(c) {0}

(d) {}

Answer: d**Explanation:**

Null set is the subset of all given sets.

Question 48 **$A = \{x: x \neq x\}$ represents**

(a) {0}

(b) {}

(c) {1}

(d) {x}

Answer: b**Explanation:**

It is fundamental concept.

Question 49**If $A = \{2, 4, 5\}$, $B = \{7, 8, 9\}$, then $n(A \times B)$ is equal to**

(a) 6

(b) 9

(c) 3

(d) 0

Answer: b**Explanation:**

$$A \times B = \{(2, 7), (2, 8), (2, 9), (4, 7), (4, 8), (4, 9), (5, 7), (5, 8), (5, 9)\} \quad n(A \times B) = n$$

$$n = 3 \times 3 = 9.$$

Question 50

In a city 20 percent of the population travels by car, 50 percent travels by bus and 10 percent travels by both car and bus. Then persons travelling by car or bus are

- (a) 80 percent (b) 40 percent
(c) 60 percent (d) 70 percent

Answer: c**Explanation:**

Given that, $n(C) = 20\%$, $n(B) = 50\%$, $n(C \cap B) = 10\%$

Population who travel by car or bus is represented by $n(C \cup B)$

We know that, $n(C \cup B) = n(C) + n(B) - n(C \cap B)$

$$= 20\% + 50\% - 10\%$$

$$= 60\%$$

Hence 60% of the population travel by car or bus.

Question 51

At a certain conference of 100 people there are 29 Indian women and 23 Indian men, out of these Indian people 4 are doctors and 24 are either men or doctor. There are no foreign doctors. The numbers of women doctors attending the conference is:

- (a) 2 (b) 4
(c) 1 (d) None of these

Answer: c**Explanation:**

Let, M = Indian men, W = Indian women, D = Indian doctors.

According to question, $n(M \cup D) = 24$, $n(M) = 23$, $n(W) = 29$, $n(D) = 4$.

As per the set rule, $n(M \cup D) = n(M) + n(D) - n(M \cap D)$. This implies, $n(M \cap D) = 3$.

Since, three men are doctors, therefore, number of women doctors = $4 - 3 = 1$

Question 52

The minimum value of the function $f(x) = x^2 - 6x + 10$ is:

- (a) 1 (b) 2
(c) 3 (d) 10

Answer: a**Explanation:**

$$F(x) = x^2 - 6x + 10$$

$$F(x) = 2x - 6$$

$$F(x) = 0 \rightarrow 2x = 6 \rightarrow x = 3$$

$$F(3) = 3^2 - 6 \times 3 + 10 = 9 - 18 + 10 = 1$$

Question 53

If $f(x) = x^3 + \frac{1}{x^4}$ then value of $f(x) - f(1/x)$ is equal to

- (a) 0 (b) 1
(c) $x^3 + \frac{1}{x^4}$ (d) None of these

Answer: a

Explanation:

$$x^3 + \frac{1}{x^4} - \frac{1}{x^3} + x^4$$

$$\frac{x^3}{x^3} + \frac{x^4}{x^4}$$

$$-1+1 = 0$$

Question 54

The relation "Is parallel to" over the set of straight line in a given plane is:

- (a) Reflexive (b) Symmetric
(c) Transitive (d) Equivalence Relation

Answer: d**Explanation:**

Equivalent relation: An equivalent relation on a set S, is a relation on S which is reflexive, symmetric and transitive. Example: Let S = Z and define R = {(x, y) x and y have the same parity} i.e. x and y are either both even or both odd.

PREPARE FOR WORST**Question 1**

If A = [(x, y): x² + y² = 25] and B = [(x, y) : x² + 9y² = 144], then A ∩ B contains _____ points.

- (a) 6 (b) 8
(c) 16 (d) 4

Question 2

In a college of 300 students, every student reads 5 newspapers and every newspaper is read by 60 students. The number of newspapers is

- (a) 25 (b) 18
(c) 16 (d) 78

Question 3

If $f(x) = \frac{x-3}{x+1}$, then $f[f(f(x))]$ equals ____ .

- (a) $f\left(\frac{[3+x]}{[1-x]}\right)$ (b) $f\left(\frac{[89+x]}{[1-x]}\right)$
(c) $f\left(\frac{[3-x]}{[1-x]}\right)$ (d) none

Question 4

Let $f: \mathbb{R} \rightarrow \mathbb{R}$ be defined by $f(x) = 2x + |x|$, then $f(2x) + f(-x) - f(x) = \underline{\hspace{2cm}}$.

- (a) 4x (b) 2|x|
(c) 3|x| (d) none

Question 5

If $f(x) = \frac{x^2-1}{x^2+1}$, for every real number. Then what is the minimum value of f?

- (a) 1 (b) 2
(c) 3 (d) 4

Question 6

The Cartesian product A × A has 9 elements among which are found (-1, 0) and (0, 1). Find the set A and the remaining elements of A × A.

- (a) $(-1, -1), (-1, 1), (0, -1), (0, 0), (1, -1), (1, 0)$ and $(1, 1)$
 (c) Neither a or b
- (b) $(-1, 1), (1, 1), (0, -1), (0, 0), (1, -1), (1, -1)$ and $(1, 1)$.
 (d) can't Justify

Question 7

Express the function $f: A \rightarrow R$. $f(x) = x^2 - 1$. Where $A = \{-4, 0, 1, 4\}$ as a set of ordered pairs.

- (a) $\{(-4, 15), (0, -1), (1, 0), (4, 15)\}$
 (c) Neither a or b
- (b) $(-1, 1), (1, 1), (0, -1), (0, 0), (1, -1), (1, -1)$ and $(1, 1)$.
 (d) $\{(4, 15), (1, 1), (1, 0), (4, -15)\}$

Question 8

Assume that $A = \{1, 2, 3 \dots 14\}$. Define a relation R from A to A by $R = \{(x, y): 3x - y = 0, \text{ such that } x, y \in A\}$. Determine and write down its range, domain, and codomain.

Question 9

If $R = \{(a, a^3): a \text{ is a prime number less than } 5\}$ is a relation. Find the Range of R .

- (a) $\{8, 27\}$
 (c) Neither a or b
- (b) $\{-8, 27\}$
 (d) Both a & b

Question 10

If $R = \{(x, y): x + 2y = 8\}$ is a relation on N , then write the range of R .

- (a) $\{8, 2, 7\}$
 (c) Neither a or b
- (b) $\{3, 2, 1\}$
 (d) Both a & b

Question 11

If $A = \{1, 2, 3\}$; $B = \{4, 5, 6, 7\}$ and $f = \{(1, 4), (2, 5), (3, 6)\}$ is a function from A to B . State whether f is one-one or not

- (a) One - One
 (C) One to Many
- (b) One- Two
 (d) Many to One

ANSWERS AVAILABLE ON:

- TELEGRAM CHANNEL: t.me/KINSHUKInstitute
- WEBSITE : WWW.KITest.IN
- KITest APP

PAST EXAMINATION QUESTIONS:

MAY 2018

Question 1

Let N be the set of all natural numbers; E be the set of all even natural numbers then the function

$f: N \rightarrow E$ defined as $f(x) = 2x - \forall x \in N$ is =

- (a) One-one-into
 (c) One-one onto
- (b) Many-one-into
 (d) Many-one-onto

Answer: c**Given**

$$N = \{1, 2, 3, 5, 6, \dots, \infty\}$$

$$E = \{2, 4, 6, 8, \dots, \infty\}$$

$$F: N \rightarrow E$$

$$f(x) = 2x - V \times EN$$

$$F(x) = -2x$$

$$F(1) = 2 \times 1 = 2$$

$$F(2) = 2 \times 2 = 4$$

$$F(3) = 2 \times 3 = 6$$

$$\text{Range of function} = \{2, 4, 6, \dots\} = E$$

$$\text{And } f(X1) = f(X2)$$

$$2 \times 1 = 2 \times 2 = X2$$

So $f(x)$ function is one-one and onto.

Question 2

In a town of 20,000 families it was found that 40% families buy newspaper. A₁ 20% families buy newspaper B and 10% families buy newspaper C, 5% families buy A and B, 3% buy B and C and A and C if 2% families buy all the three newspapers, then the number of families which by A only is :

(a) 6600

(b) 6300

(c) 5600

(d) 600

Answer: a**Explanation:**

$$\text{Total Families } n(u) = 20000$$

$$\text{No. of families who buy Newspapers 'A' } n(A) = 40\% \text{ of } 20000 = 8000$$

$$\text{No. of families who buy Newspapers 'B' } n(B) = 20\% \text{ OF } 2000 = 4000$$

$$\text{No. of families who buy Newspapers 'C'}$$

$$n(C) = 10\% \text{ of } 20000 = 2000$$

$$\text{No. of families who buy Newspapers A \& B}$$

$$n(A \cap B) = 5\% \text{ OF } 20000 = 1000$$

$$\text{No. of families who buy Newspapers B \& C}$$

$$n(B \cap C) = 3\% \text{ OF } 20000 = 600$$

$$\text{No. of families who buy Newspapers C \& A}$$

$$n(C \cap A) = 4\% \text{ OF } 20000 = 800$$

$$\text{No. of families who buy all Newspapers } n(A \cap B \cap C) = 2\% \text{ OF } 20000 = 400$$

$$\text{No. of families who buy Newspapers 'A' only}$$

$$= n(A \cap B \cap C)$$

$$= n(A) - n(A \cap B) - n(A \cap C) + n(n B \cap C)$$

$$= 8000 - 1000 - 800 + 400$$

$$= 6600$$

Question 3

The numbers of proper sub set of the set {3, 4, 5, 6, and 7} is:

(a) 32

(b) 31

(c) 30

(d) 25

Answer: b

$$A = \{3, 4, 5, 6, 7\}$$

$$n(A)' = 5$$

If $A = \{1, 2, 3, 4, 5, 6, 7\}$ and $B = \{2, 4, 6, 8\}$. Cardinal member of $A - B$ is:

- (a) 4 (b) 3
(c) 9 (d) 7

Answer: a

Explanation:

$$A = \{1, 2, 3, 4, 5, 6, 7\}$$

$$B = \{2, 4, 6, 8\}$$

$$A - B = \{1, 2, 3, 4, 5, 6, 7\} - \{2, 4, 6, 8\}$$

$$= \{1, 3, 5, 7\}$$

$$n(A - B) = 4$$

Question 4

Identify the function from the following:

- (a) $\{(1,1), (1,2), (1,3)\}$ (b) $\{(1, 1), (2, 1), (2, 3)\}$
(c) $\{(1, 2), (2,2), (3,2), (4,2)\}$ (d) None of these

Answer: c

Explanation:

$\{(1, 2), (2,2), (3,2), (4,2)\}$ is the function

Many one function

MAY 2019

Question 1

If $A = \{1, 2, 3, 4, 5, 6, 7, 8, 9\}$

$B = \{1, 3, 5, 7, 8\}$; $C = \{2, 6, 8\}$ then find $= (A - B) \cup C$

- (a) $\{2, 6\}$ (b) $\{2, 6, 8\}$
(c) $\{2, 6, 8, 9\}$ (d) None of these

Answer: c

Explanation:

$$A = \{1, 2, 3, 4, 5, 6, 7, 8, 9\}$$

$$B = \{1, 3, 4, 5, 7, 8\}$$

$$C = \{2, 6, 8\}$$

$$A - B = \{2, 6, 9\}$$

$$(A - B) \cup C = \{2, 6, 8, 9\}$$

Question 2

If $(x) = x^2$ and $x=g(x) \sqrt{x}$ then

- (a) $g \circ f(3) = 3$ (b) $g \circ f(-3) = 9$
(c) $g \circ f(9) = 3$ (d) $g \circ f(-9) = 3$

Answer: a

Explanation:

$$g \circ f = g(f(x)) = \sqrt{x^2}$$

$$g \circ f = x \quad \dots \dots \dots (1)$$

Put this equations in above objectives

Option first:

$$g \circ f(3) = 3$$

Hence option 1 is correct

Question 3

$A = \{1, 2, 3, 4, \dots, 10\}$ a relation on A , $R = \left\{ \frac{(x,y)}{x+y} = 10, x \in A, y \in A, X \geq Y \right\}$ then Domain of R^{-1} is

- (a) $\{1, 2, 3, 4, 5\}$ (b) $\{0, 3, 5, 7, 9\}$
 (c) $\{1, 2, 4, 5, 6, 7\}$ (d) None of these

Answer: a**Explanation:** $\{1, 2, 3, 4, 5\}$ **Question 4**

If $A = \{a, b, c, d\}$; $B = \{p, q, r, s\}$ which of the following relation is a function from A to B

- (a) $R_1 = \{(a, p), (b, q), (c, s)\}$ (b) $R_2 = \{(p, a), (b, r), (d, s)\}$
 (c) $R_3 = \{(b, p), (c, s), (b, r)\}$ (d) $R_4 = \{(a, p)(b, r)(c, q), (d, s)\}$

Answer: d**Explanation:**

Unique mapping: A map is way of associating unique objects to every element in a given set. So a map from to is a function such that for every, there is a unique object. The terms function and mapping are synonymous for map.

NOV 2019**Question 1** $(A^T)^T = ?$

- (a) A (b) A^T
 (c) $A^T \cdot A^T$ (d) A^{2T}

Answer: a**Explanation:**(a) $(A^T)^T = A$ Example $A = \begin{pmatrix} 1 & 2 \\ 3 & 4 \end{pmatrix}$

$$A^T = \begin{pmatrix} 1 & 3 \\ 2 & 4 \end{pmatrix}$$

$$(A^T)^T = \begin{pmatrix} 1 & 2 \\ 3 & 4 \end{pmatrix} = A$$

So, $(A^T)^T = A$ **Question 2**

$F(n) = f(n-1) + f(n-2)$ when $n = 2, 3, 4, \dots, f(0) = 0,$

$F(1) = 1$ then $f(7) = ?$

- (a) 3 (b) 5
 (c) 8 (d) 13

Answer: d**Explanation:**(d) $F(n) = f(n-1) + f(n-2)$ $F(2) = f(1) + f(0) = 1 + 0 = 1 = f(2)$ $F(3) = f(2) + f(1) = 1 + 1 = 2 = f(3)$ $F(4) = f(3) + f(2) = 2 + 1 = 3$

Similarly,

$$\begin{aligned}
 f(7) &= f(6) + f(5) \\
 f(7) &= [f(5) + f(4) + [f(4) + f(3)]] \\
 f(7) &= [f(4) + f(3) + f(4)] + (f(4) + f(3)) \\
 f(7) &= [3 + 2 + 3] + [3 + 2] \\
 r(7) &= 13
 \end{aligned}$$

Question 3

$$f(x) = x + \frac{1}{x} \text{ find } f^{-1}(y)$$

(a) $\frac{1}{(x-1)}$

(b) $\frac{1}{(y-1)}$

(c) 1_1

(d) x

Answer: a**Explanation:**

(a) $F(x) = \frac{x+1}{x}$ Equation (1)

Let $f(x) = y$

$X = f^{-1}(y)$

Further SolvingEquation (1)

$Y = \frac{x+1}{x}$

$XY = x + 1 \Rightarrow xy - x = 1 \Rightarrow x(y - 1) = 1$

$X = \frac{1}{(y-1)}$

$f^{-1}(y) = \frac{1}{(y-1)}$

$f^{-1}(y) = \frac{1}{(x-1)}$

DEC 2020**Question 1**

Two finite sets respectively have x and y number of elements. The total number of subsets of the first is 56 more than the total no. of sub sets of the second. The values of x,y are respectively ____

(a) 4 and 2

(b) 6 and 3

(c) 2 and 4

(d) 3 and 6

Answer: d**Explanation:**

Let A has x elements

Let B has y elements

Total number of students of A = 2^m Total number of students of B = 2^n It is given $\Rightarrow 2^m - 2^n = 56$

$2y(2x - y - 1) = 56$

$\Rightarrow 2^y = \text{even and } 2^{x-y} - 1 = 0$ Basic odd

Now,

$56 = 8 \times 7 = 2^3 \times 7$

$\Rightarrow 2^y (2^{x-y} - 1) = 2^3 \times 7$

$\Rightarrow n = 3$

Now, $8(2^{y-3} - 1) = 8 \times 7$

$\Rightarrow 2^{y-3} - 1 = 7$

$\Rightarrow 2^{y-3} = 8 = 2^3$

$$\Rightarrow y - 3 = 3$$

$$\Rightarrow y = 6.$$

Question 2

The number of items in the set A is 40, in the Set B is 32; in the Set C is 50; in both A and B is 4; in both A and C is 5; in both B and C is 7; in all the set is 2. How many are in only one set?

- (a) 96 (b) 110
(c) 106 (d) None of these

Answer: d**Explanation:**

\therefore In only one set,
There are $29 + 19 + 36$
 $= 84$

Hence, D is the correct option.

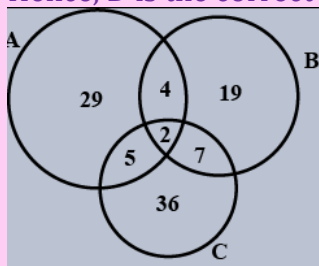
**Question 3**

The set of cubes of natural numbers is

- (a) Null set (b) Finite set
(c) Infinite set (d) A finite set of three numbers

Answer: c**Explanation:**

A set is countably infinite if its elements can be put in one-to-one correspondence with the set of natural numbers. For example, the set of integers $\{0, 1, -1, 2, -2, 3, -3, \dots\}$ is clearly infinite.

Question 4

The inverse function f^{-1} of $F(y) = 3x$ is _____

- (a) $1/3y$ (b) $y/3$
(c) $-3y$ (d) $1/y$

Answer: b**Explanation:**

$$F(y) = 3x$$

$$y = 3x$$

$$x = \frac{y}{3}$$

$$y = \frac{x}{3} \quad \text{so } x = \frac{y}{3}$$

JAN 2021

Question: 1

The set of cubes of natural number is

- (a) Null set (b) A finite set
(c) An infinite set (d) Singleton set

Answer: c

Explanation:

The set of cubes of the natural numbers is an infinite set.

Question: 2

In the set of all straight lines on a plane which of the following is Not True?

- (a) 'Parallel to' an equivalent relation (b) 'Perpendicular to' is a symmetric relation
(c) 'Perpendicular to' is an equivalence relation (d) 'Parallel to' is a reflexive relation.

Answer: c

Explanation:

'Perpendicular to' is an equivalence relation

Question: 3

Let $f: \mathbb{R} \rightarrow \mathbb{R}$ be defined by

$$f(x) = \begin{cases} 2x & \text{for } x > 3 \\ x^2 & \text{for } 1 < x \leq 3 \\ 3x & \text{for } x \leq 1 \end{cases}$$

The value of $f(-1) + f(2) + f(4)$ is

- (a) 9 (b) 14
(c) 5 (d) 6

Answer: a

Explanation:

$$\text{Given that } f(x) = \begin{cases} 2x & \text{for } x > 3 \\ x^2 & \text{for } 1 < x \leq 3 \\ 3x & \text{for } x \leq 1 \end{cases}$$

$$f(-1) = 3(-1) = -3$$

$$f(2) = 2^2 = 4$$

$$f(4) = 2(4) = 8$$

$$= -3 + 4 + 8 = 9$$

JULY 2021

Question 1

Let U be the universal set, A and B are the subsets of U. If $n(U) = 650$, $n(A) = 310$, $n(A \cap B) = 95$ and $n(B) = 190$, then $n(\bar{A} \cap \bar{B})$ is equal to (\bar{A} and \bar{B} are the complements of A and B respectively)

- (a) 400 (b) 300
(c) 200 (d) 245

Answer: Options (d)

Explanation:

Let

$$n(U) = 650, n(A) = 310, n(A \cap B) = 95, n(B) = 190$$

$$n(A \cap B) = 95, n(A' \cap B')$$

Now,

$$n(A \cap B) = n(A \cup B)$$

$$= n(U) - n(A \cup B)$$

$$\begin{aligned}
 &= n(U) - \{n(A) + n(B) + n(A \cap B)\} \\
 &= 650 - \{310 + 190 - 95\} \\
 &= 245
 \end{aligned}$$

Question 2

The range of function f defined by $f(x) = \sqrt{16 - x^2}$ is

- (a) $[-4, 0]$ (b) $[-4, 4]$
 (c) $[0, 4]$ (d) $(-4, 4)$

Answer: Options (c)

Explanation:

Since square root can only take positive value so

$$-4 \leq x \leq 4 \Rightarrow \sqrt{16 - x^2} \in [0, 4]$$

Hence, option 'C' is correct.

Question 3

Let $A = \mathbb{R} - \{3\}$ and $B = \mathbb{R} - \{1\}$. Let $f: A \rightarrow B$ defined by $f(x) = \frac{x-2}{x-3}$ what is value of $f^{-1}\left(\frac{1}{2}\right)$?

- (a) $2/3$ (b) $3/4$
 (c) 1 (d) -1

Answer: Options (c)

$$A = \mathbb{R} - 3, B = \mathbb{R} - 1$$

$$F(x) = \frac{x-2}{x-3}$$

$f: A \rightarrow B$ defined as

Let, $x, y \in A$ such that $f(x) = f(y)$

$$\Rightarrow \frac{x-2}{x-3} = \frac{y-2}{y-3}$$

$$\Rightarrow x - 2y - 3 = y - 2x - 3$$

$$\Rightarrow xy - 3x - 2y + 6 = xy - 3y - 2x + 6$$

$$\Rightarrow -3x - 2y = -3y - 2x$$

$$\Rightarrow 3x - 2x = 3y - 2y$$

$$\Rightarrow x = y$$

$\therefore f$ is one - one.

Question 4

If $f(x) = x^2 - 1$ and $g(x) = |2x + 3|$, then $f \circ g(3) - g \circ f(-3) =$

- (a) 71 (b) 61
 (c) 41 (d) 51

Answer: Options (b)

DEC 2021

Question 1

Out of group of 20 teachers in a school, 10 teach mathematics, 9 teach Physics and 7 teach Chemistry. 4 teach Mathematics and Physics but none teach both mathematics and chemistry. How many teach chemistry and Physics; how many teach only Physics?

- (a) 2, 3 (b) 3, 2

(c) 4, 6

(d) 6, 4

Answer: a**Explanation:**

Let the number of teachers teaching both physics and chemistry be x

In the absence of information, it is safe to assume that all the teachers teach at least one of the subjects. Therefore,

$$9-x-0-4-x+7-x-0-0+4+0+0+6=20$$

$$=9-4+7+4+6-x+x-x=20$$

$$\Rightarrow x=22-20=2$$

Therefore, number of teachers teaching both physics = $9-2-4=3$

Question 2

If a related to b if and only if the difference in a and b is an even integer. This relation is

(a) Symmetric, reflexive but not transitive

(b) symmetric, transitive but not reflexive

(c) transitive, reflexive but not symmetric

(d) equivalence relation

Answer: d**Explanation:****1. Check for Reflexivity:**

(a) A relation is reflexive if every element has a relation with itself.

(b) In this question, the relation exists only if the difference between the elements is an even integer.

(c) Take, for example, the number 2. Now, for this relation to be a reflexive relation, this element 2 would have to have a relation with itself.

(d) $2-2=0$, which is an even integer.

(e) Therefore, any element can have a relation with itself, and hence, this is a reflexive relation.

2. Check for Symmetry:

(a) A relation is symmetric if $(a, b) \in R \Rightarrow (b, a) \in R$.

(b) Take two integers, 2 and 6.

(c) Here, $2-6=-4$, which is an even integer.

(d) Also, $6-2=4$, which is an even integer.

(e) Therefore, $(2, 6) \in R$ and $(6, 2) \in R$.

(f) Therefore, this is a symmetric relation.

3. Check for Transitivity:

(a) A relation is transitive if $(a, b) \in R$, and $(b, c) \in R \Rightarrow (a, c) \in R$.

(b) Take the values of a, b, and c to be 2, 6, and 10 respectively.

(c) Now, $a=2$; $b=6$; $c=10$

(d) Clearly, $(a, b) \in R$ as $2 - 6 = -4$, which IS an even integer.

(e) Also, $(b, c) \in R$ as $6 - 10 = -4$, which is an even integer.

(f) Also, $(a, c) \in R$ as $2 - 10 = -8$, which is an even integer.

(g) Therefore, this relation is a transitive relation.

Since this relation is a Reflexive, Symmetric, as well as a Transitive Relation, it is an Equivalence Relation.

Question 3

If $u(x) = \frac{1}{1-x}$ then $u'(x)$ is:

(a) $\frac{1}{x-1}$

(b) $1-x$

(c) $1 - \frac{1}{x}$

(d) $\frac{1}{x} - 1$

Answer:

Explanation:

Let $y = u(x)$

Therefore, $y = \frac{1}{1-x}$

$$y(1-x) = 1$$

$$y - xy = 1$$

$$y - 1 = xy$$

$$xy = y - 1$$

$$x = \frac{y-1}{y}$$

Now, simply replace x with $u^{-1}(x)$, and y with x , and you'll get the answer

$$u^{-1}(x) = \frac{x-1}{x}$$

$$u^{-1}(x) = \frac{x}{x} - \frac{1}{x}$$

$$u^{-1}(x) = 1 - \frac{1}{x}$$

JUNE 2022

Question 1

$f(x) = \{(2, 2); (3, 3); (4, 4); (5, 5); (6, 6)\}$ be a relation of set $A = \{2, 3, 4, 5, 6\}$

It is a:

(a) Reflexive and Transitive

(b) Reflexive and Symmetric

(c) Reflexive only

(d) An equivalence

Answer: Options (c)

Explanation:

If $f(x) = \{(2, 2), (3, 3), (4, 4), (5, 5), (6, 6)\}$

be the Relation of $A = \{2, 3, 4, 5, 6\}$

It is a Reflexive only.

Question 2

If $f(y) = \frac{y-1}{y}$, find $f^{-1}(x)$.

(a) $\frac{1}{1-y}$

(b) y

(c) $\frac{y}{y-1}$

(d) $\frac{y}{1-y}$

Answer: Options (a)

Explanation:

$$\text{Given } f(y) = \frac{y-1}{y}$$

$$\text{Let } f(y) = x \Rightarrow y = f^{-1}(x)$$

$$x = \frac{y-1}{y}$$

$$xy = y - 1$$

$$xy - y = -1$$

$$y((x-1) = -1$$

$$y = \frac{-1}{(x-1)}$$

$$f^{-1}(x) = \frac{1}{(x-1)}$$

$$f^{-1}(y) = \frac{-1}{(y-1)} = \frac{1}{1-y}$$

Question 3

Two finite sets have x and y number of elements. The total number of subsets of first is 56 more than the total number of subsets of second. The value of x and y is:

(a) 6 and 3

(b) 4 and 2

(c) 2 and 4

(d) 3 and 4

Answer: Options (a)

Explanation:

$$\text{Let set } A = \{1, 2, 3, \dots, x\}$$

$$\text{No. of subsets of } A = 2^x$$

$$\text{and Set } B = \{1, 2, 3, \dots, y\}$$

$$\text{No. of subset of } B = 2^y$$

$$\text{Given, } 2^x = 2^y + 56 \dots\dots\dots(1)$$

Hits & $x = 6, y = 3$ is satisfied this equation,

So $x = 6$ and $y = 3$.

Question 4

Given $A = \{2, 3\}$, $B = \{4, 5\}$, $C = \{5, 6\}$ then $A \times (B \cap C)$ is:

(a) $\{(2, 5), (3, 5)\}$

(b) $\{(5, 2), (5, 3)\}$

(c) $\{(2, 3), (5, 5)\}$

(d) None of these

Answer: Options (a)

Explanation:

$$A = \{2, 3\}, B = \{4, 5\}, C = \{5, 6\}$$

$$B \cap C = \{5\}$$

$$A \times (B \cap C) = \{2, 3\} \times \{5\}$$

$$= \{(2, 5), (3, 5)\}$$

Question 5

If the universal set $E = \{x : x \text{ is a positive integer } < 25\}$, $A = \{2, 6, 8, 14, 22\}$, $B = \{4, 8, 10, 14\}$

- (a) $(A \cap B)' = A' \cup B'$ (b) $(A \cap B)' = A' \cap B'$
 (c) $(A \cap B)' = \phi$ (d) None of these

Answer: Options (a)

Explanation:

If $E = \{x : x \text{ is a positive Integers } < 25\}$

$A = \{2, 6, 8, 14, 22\}$

$B = \{4, 8, 10, 14\}$

then $(A \cap B)' = A' \cup B'$ [Demorgan Law]

\therefore Demorgan law is universal truth.

DEC 2022

Question 1

If $A = \{1, \bar{2}, 3, \bar{4}, 5, \bar{7}, 8, \bar{9}\}$ and $\{2, 4, 6, 7, 9\}$ then how many proper subset of $A \cap B$ can be created

- a) 16 (b) 15
 c) 32 (d) 31

Answer: Options (b)

Explanation:

Given:

$A = \{1, 2, 3, 4, 5, 7, 8, 9\}$ and $B = \{2, 4, 6, 7, 9\}$

As we know that $A \cap B = \{x : x \in A \text{ and } x \in B\}$

$A \cap B = \{2, 4, 7, 9\}$

As we can see that,

The number of elements present in $A \cap B = 4$

i.e $n(A \cap B) = 4$

As we know that;

If A is a non-empty set such that $n(A) = m$ then

The numbers of proper subsets of A are given by $2^m - 1$.

So, The number of proper subsets of $A \cap B = 2^4 - 1 = 15$

Hence, the correct option is 2

Question 2

Let $A = \{1, 2, 3\}$ and consider the relation $R = \{(1, 1), (2,2), (3,3), (1, 2), (2, 3), (1, 3)\}$, Then R is:

- a) symmetric and transitive (b) reflexive but not transitive
 c) reflexive but not symmetric (d) neither symmetric, nor transitive

Answer: Options (c)

Explanation:

Let $A = \{1, 2, 3\}$ and consider the relation $R = \{(1, 1), (2, 2), (3, 3), (1, 2), (2, 3), (1, 3)\}$. Then R is reflexive but not symmetric.

Explanation:

Given that $A = \{1, 2, 3\}$

$R = \{(1, 1), (2, 2), (3, 3), (1, 2), (2, 3), (1, 3)\}$

$\forall (1, 1), (2, 2), (3, 3) \in R$

Hence, R is reflexive.

$(1, 2) \in R$ but $(2, 1) \notin R$
 Hence, R is not symmetric.
 $(1, 2) \in R$ and $(2, 3) \in R$
 $\rightarrow (1, 3) \in R$
 Hence, R is transitive.

Question 3

The number of subsets of the set {0, 1, 2, 3} is

- | | |
|------|-------|
| a) 2 | b) 4 |
| c) 8 | d) 16 |

Answer: Options (c)

Explanation:

A subset is a part of the set.
 Given, set = {1, 2, 3}
 We have to find the total number of subsets.
 A set with 'n' elements in it can have 2^n subsets.
 So, total number of subset = $2^3 = 8$
 The possible subsets are:
 {1}, {2}, {3}, {1, 2}, {1, 3}, {2, 3}, {1, 2, 3} and {}
 Where, {} is the empty set.
 Therefore, the number of subsets is 8.

Question 4

In a given set if all data are of same value then variance would be:

- | | |
|-------|--------|
| a) 0 | b) 1 |
| c) -1 | d) 0.5 |

Answer: Options (a)

Explanation:

Variance is the degree of spread or change in the given data points. The variance is calculated in relation to the mean of the data. The more the spread of the data, the more will be the variance in relation to the mean.

The formula for variance:

$$\sigma^2 = \sum (X - \mu)^2 / N,$$

σ^2 = sample variance

X = each data value

μ = mean of the data set

N = total number of data set

Special case: When all the data set points are the same.

In this case, the mean of the data set i.e. μ is the same as each data value i.e. X.

So, $X = \mu$.

Thus, $X - \mu = 0$

Hence, variance becomes 0.

In order to calculate the variance of the given data set, we can make use of the online variance calculator.

So, the variance of the data set in which each value is similar will be equal to 0.

CHAPTER - 8 BASIC CONCEPTS OF DIFFERENTIAL AND INTEGRAL CALCULUS

(A) DIFFERENTIAL CALCULUS

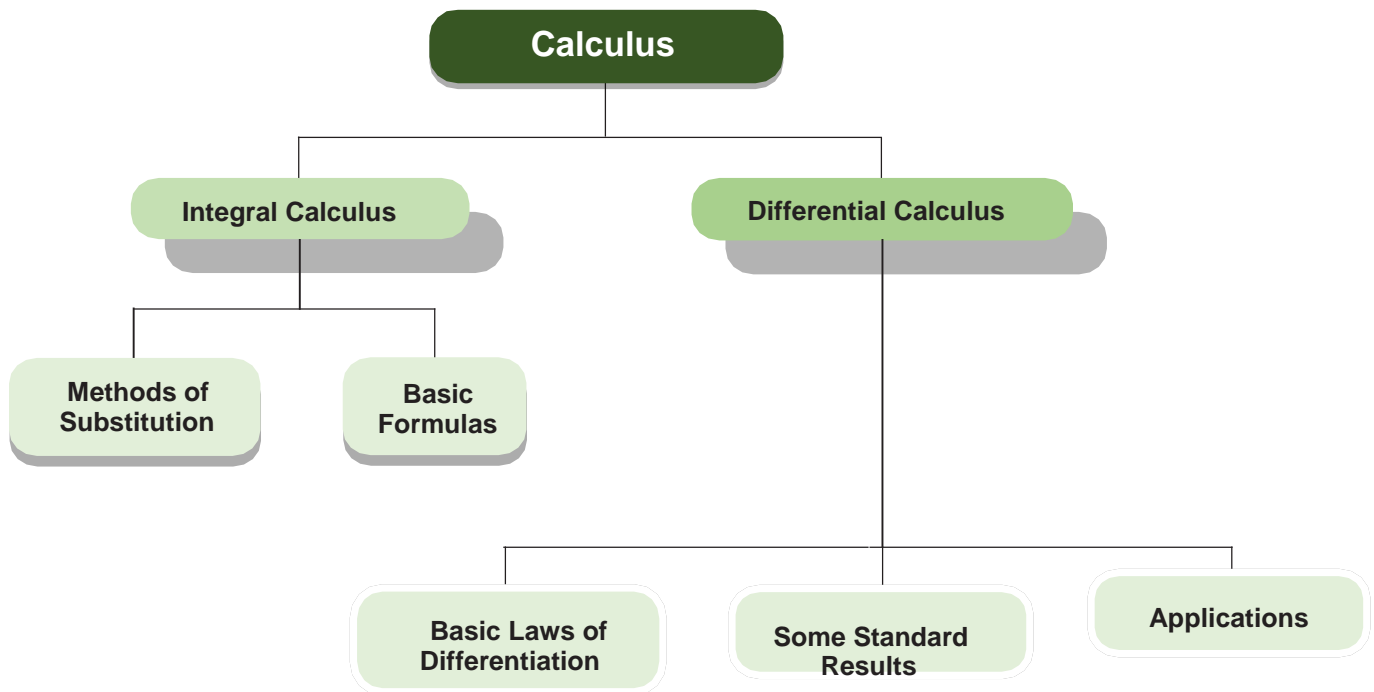

INTRODUCTION	Differentiation is one of the most important fundamental operations in calculus. Its theory primarily depends on the idea of limit and continuity of function.
DERIVATIVE OR DIFFERENTIAL COEFFICIENT	Let $y = f(x)$ be a function. If h be the small increment in x and the corresponding increment in y or $f(x)$ be $y = f(x+h) - f(x)$
STANDARD FORMULAS	

$\frac{d}{dx}(a) = 0$	$\frac{d}{dx}[\ln u] = \frac{d}{dx}[\log_e u] = \frac{1}{u} \frac{du}{dx}$
$\frac{d}{dx}(x) = 1$	$\frac{d}{dx}[\log_a u] = \log_a e \frac{1}{u} \frac{du}{dx}$
$\frac{d}{dx}(au) = a \frac{du}{dx}$	$\frac{d}{dx} e^u = e^u \frac{du}{dx}$
$\frac{d}{dx}(u + v - w) = \frac{du}{dx} + \frac{dv}{dx} - \frac{dw}{dx}$	$\frac{d}{dx} a^u = a^u \ln a \frac{du}{dx}$
$\frac{d}{dx}(uv) = u \frac{dv}{dx} + v \frac{du}{dx}$	$\frac{d}{dx}(u^v) = v u^{v-1} \frac{du}{dx} + \ln u \cdot u^v \frac{dv}{dx}$
$\frac{d}{dx}\left(\frac{u}{v}\right) = \frac{1}{v} \frac{du}{dx} - \frac{u}{v^2} \frac{dv}{dx}$	$\frac{d}{dx} \sin u = \cos u \frac{du}{dx}$
$\frac{d}{dx}(u^n) = n u^{n-1} \frac{du}{dx}$	$\frac{d}{dx} \cos u = -\sin u \frac{du}{dx}$
$\frac{d}{dx}(\sqrt{u}) = \frac{1}{2\sqrt{u}} \frac{du}{dx}$	$\frac{d}{dx} \tan u = \sec^2 u \frac{du}{dx}$
$\frac{d}{dx}\left(\frac{1}{u}\right) = -\frac{1}{u^2} \frac{du}{dx}$	$\frac{d}{dx} \cot u = -\csc^2 u \frac{du}{dx}$
$\frac{d}{dx}\left(\frac{1}{u^n}\right) = -\frac{n}{u^{n+1}} \frac{du}{dx}$	$\frac{d}{dx} \sec u = \sec u \tan u \frac{du}{dx}$
$\frac{d}{dx}[f(u)] = \frac{d}{du}[f(u)] \frac{du}{dx}$	$\frac{d}{dx} \csc u = -\csc u \cot u \frac{du}{dx}$

<p>IMPLICIT FUNCTIONS</p>	<p>A function in the form $f(x, y) = 0$. For example, $x^2y^2 + 3xy + y = 0$ where y cannot be directly defined as a function of x is called an implicit function of x.</p>
<p>PARAMETRIC EQUATION</p>	<p>When both the variables x and y are expressed in terms of a parameter (a third variable), the involved equations are called parametric equations. For the parametric equations $x = f(t)$ and $y = h(t)$ the differential coefficient $\frac{dy}{dx}$</p>
<p>LOGARITHMIC DIFFERENTIATION</p>	<p>The process of finding out derivative by taking logarithm in the first instance is called logarithmic differentiation.</p>

GEOMETRIC INTERPRETATION OF THE DERIVATIVE

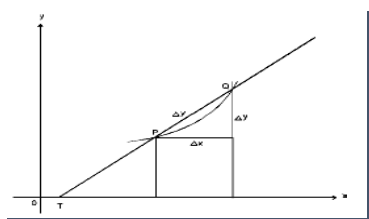

COST FUNCTION	Total cost consists of two parts (i) Variable Cost (ii) Fixed Cost.	
	Average cost (AC or C)	$\frac{\text{Total Cost } C(X)}{\text{Output } \bar{X}}$
	Average variable cost (AVC)	$\frac{\text{Variable Cost } V(X)}{\text{Output } \bar{X}}$
	Average Fixed Cost (AFC)	$\frac{\text{Fixed Cost } F(X)}{\text{Output } \bar{X}}$
MARGINAL COST	If $C(x)$ the total cost producing x units then the increase in cost in producing one more unit is called marginal cost at an output level of x units	
REVENUE FUNCTION	Revenue, $R(x)$, gives the total money obtained (Total turnover) by selling units of a product. If x units are sold at P per unit, then $R(x)=P.X$	
PROFIT FUNCTION	Profit $P(x)$, the difference of between total revenue $R(x)$ and total Cost $C(x)$.	

(B) INTEGRAL CALCULUS

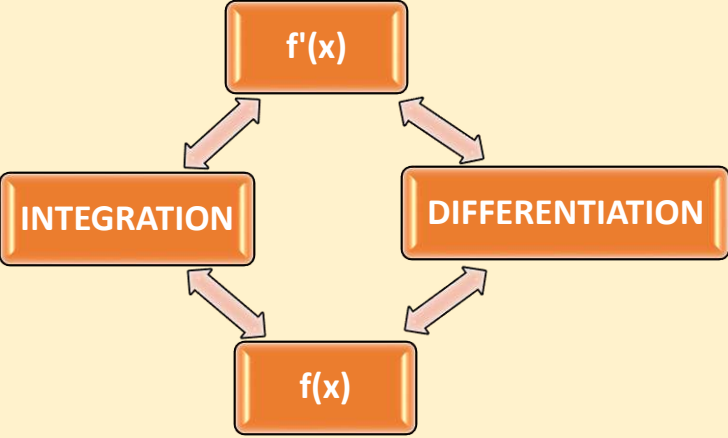
INTEGRATION	
	Integration is the reverse process of differentiation.

DEFINITE INTEGRATION

DEFINITION The collection of all antiderivatives of f is called the **indefinite integral** of f with respect to x , and is denoted by

$$\int f(x) dx.$$

The symbol \int is an **integral sign**. The function f is the **integrand** of the integral, and x is the **variable of integration**.

Differentiation Formulas:

1. $\frac{d}{dx}(x) = 1$
2. $\frac{d}{dx}(ax) = a$
3. $\frac{d}{dx}(x^n) = nx^{n-1}$
4. $\frac{d}{dx}(\cos x) = -\sin x$
5. $\frac{d}{dx}(\sin x) = \cos x$
6. $\frac{d}{dx}(\tan x) = \sec^2 x$
7. $\frac{d}{dx}(\cot x) = -\csc^2 x$
8. $\frac{d}{dx}(\sec x) = \sec x \tan x$
9. $\frac{d}{dx}(\csc x) = -\csc x(\cot x)$
10. $\frac{d}{dx}(\ln x) = \frac{1}{x}$
11. $\frac{d}{dx}(e^x) = e^x$
12. $\frac{d}{dx}(a^x) = (\ln a)a^x$
13. $\frac{d}{dx}(\sin^{-1} x) = \frac{1}{\sqrt{1-x^2}}$
14. $\frac{d}{dx}(\tan^{-1} x) = \frac{1}{1+x^2}$
15. $\frac{d}{dx}(\sec^{-1} x) = \frac{1}{|x|\sqrt{x^2-1}}$

Integration Formulas:

1. $\int 1 dx = x + C$
2. $\int a dx = ax + C$
3. $\int x^n dx = \frac{x^{n+1}}{n+1} + C, n \neq -1$
4. $\int \sin x dx = -\cos x + C$
5. $\int \cos x dx = \sin x + C$
6. $\int \sec^2 x dx = \tan x + C$
7. $\int \csc^2 x dx = -\cot x + C$
8. $\int \sec x(\tan x) dx = \sec x + C$
9. $\int \csc x(\cot x) dx = -\csc x + C$
10. $\int \frac{1}{x} dx = \ln |x| + C$
11. $\int e^x dx = e^x + C$
12. $\int a^x dx = \frac{a^x}{\ln a} + C, a > 0, a \neq 1$
13. $\int \frac{1}{\sqrt{1-x^2}} dx = \sin^{-1} x + C$
14. $\int \frac{1}{1+x^2} dx = \tan^{-1} x + C$
15. $\int \frac{1}{|x|\sqrt{x^2-1}} dx = \sec^{-1} x + C$

Properties of Definite Integral

Assuming f and g are continuous functions

$$\int_a^b f(x)dx = \int_b^a f(x)dx$$

$$\int_a^a f(x)dx = 0$$

$$\int_a^b c dx = c(b - a), \text{ where } c \text{ is any constant}$$

$$\int_a^b cf(x)dx = c \int_a^b f(x)dx, \text{ where } c \text{ is any constant}$$

$$\int_a^b [f(x) + g(x)]dx = \int_a^b f(x)dx + \int_a^b g(x)dx$$

$$\int_a^b [f(x) - g(x)]dx = \int_a^b f(x)dx - \int_a^b g(x)dx$$

$$\int_a^b f(x)dx + \int_b^c f(x)dx = \int_a^c f(x)dx$$



Question 1

Find an expression for y given $\frac{dy}{dx} = 7x^5$

- (a) 6
(c) 3
- (b) 2
(d) 5

Answer: a

Explanation:

$$\frac{dy}{dx} = 7x^5 \rightarrow dy = 7x^5 dx$$

Integrating both sides, we have

$$\int dy = \int 7x^5 dx \rightarrow y = \frac{7x^6}{6} + c$$

Question 2

Find an expression for y given $\frac{dy}{dx} = x^{-\frac{3}{4}}$

- (a) $\frac{2}{3}$
(c) $\frac{5}{4}$
- (b) $\frac{1}{4}$
(d) None

Answer: b**Explanation:**

$$\frac{dy}{dx} = x^{-3/4}$$

$$Y = \frac{x^{-3/4+1}}{-\frac{3}{4}+1} = \frac{x^{1/4}}{1/4}$$

$$Y = 4x^{1/4}$$

Question 3**dy = ∫ -12x⁻⁴ dx solve it;**

- (a) 6 (b) 2
(c) 3 (d) 4

Answer: d**Explanation:**

$$dy = \int -12x^{-4} dx$$

$$= -12 \int x^{-4} dx$$

$$= + \left(\frac{-12x^{-3}}{-3} \right) + c$$

$$Y = 4x^{-3} + c$$

Use $\int ax^n dx = a \int x^n dx = \frac{ax^{n+1}}{n+1} + c$
 $n = -4, n + 1 = -4 + 1 = -3$
 Simplifying fraction, $\frac{-12}{3} = 4$

Question 4**Given f'(x) = $\frac{1}{2}x^{\frac{1}{3}} - \frac{1}{4}x^{\frac{1}{4}} + \pi$, find f(x)**

- (a) 6 (b) 2
(c) 3 (d) None

Answer: d**Explanation:**

$$\frac{1}{2}x^{\frac{1}{3}} - \frac{1}{4}x^{\frac{1}{4}} + \pi$$

$$\int \frac{1}{2}x^{\frac{1}{3}} dx - \int \frac{1}{4}x^{\frac{1}{4}} dx + \int \pi dx$$

$$\frac{1}{2} \int x^{\frac{1}{3}} dx - \frac{1}{4} \int x^{\frac{1}{4}} dx + \pi \int dx$$

$$= \frac{\frac{1}{2}x^{\frac{4}{3}}}{\frac{4}{3}} - \frac{\frac{1}{4}x^{\frac{5}{4}}}{\frac{5}{4}} + \frac{\pi x}{2} + C$$

$$= \frac{3x^{\frac{4}{3}}}{8} - \frac{1}{4} \times \frac{4}{5}x^{\frac{5}{4}} + \pi x + C$$

Question 5

Given $f'(x) = \int \left(\frac{2}{x} + \frac{3}{x^2} + \frac{1}{x^5} \right) dx$

- (a) -6 (b) 2
(c) -4 (d) None

Answer: c

Explanation:

$$\begin{aligned} & \int \left\{ \frac{2}{x} + \frac{3}{x^2} + \frac{1}{x^5} \right\} dx \\ &= \int \left(\frac{2}{x} + 3x^{-2} + x^{-5} \right) dx && \text{write as negative exponence} \\ &= \int \frac{2}{x} dx + \int 3x^{-2} dx + \int x^{-5} dx && \text{Use } \int f(x)dx + g(x)dx = \int f(x)dx + \int g(x)dx \\ &= 2 \ln |x| + \frac{3x^{-1}}{-1} + \frac{x^{-4}}{-4} + c && \text{Use } \int ax^n dx = a \int x^n dx = \frac{ax^{n+1}}{n+1} + c \\ &= 2 \ln |x| - \frac{3}{x} - \frac{1}{4x^4} + c && \text{Simplify } \frac{3}{-1} \end{aligned}$$

Question 6

Integrate $\int \frac{3}{x^2} dx$

- (a) $6\sqrt{x+c}$ (b) $\sqrt{x+c}$
(c) $8\sqrt{x+c}$ (d) $9\sqrt{x+c}$

Answer: a

Explanation:

$$\begin{aligned} \int \frac{3}{x^2} dx &= \int 3x^{-1/2} \\ &= \frac{3x^{-1/2+1}}{-\frac{1}{2}+1} + c \\ &= \frac{3x^{\frac{1}{2}}}{\frac{1}{2}} + c \\ &= 6x^{\frac{1}{2}} + c \\ &= 6\sqrt{x} + c \end{aligned}$$

Question 7

Find y as a function of x if $\frac{d^2y}{dx^2} = 2x$ **when** $x = 2, y = 7$

- (a) $y = \frac{x^3}{3} + c$ (b) $y = \frac{x^2}{3} + c$
(c) $y = \frac{x}{3} + c$ (d) None

Answer: a

Explanation:

$$\int 2x dx = 2 \int x dx$$

$$= \left(\frac{2x^{1+1}}{1+1} \right) + c$$

$$\frac{dy}{dx} = x^2 + c$$

$$\text{Finding } y = \int \frac{dy}{dx} = \int x^2 dx$$

$$Y = \frac{x^3}{3} + c$$

At (2, 7)

$$7 = \frac{2^3}{3} + c$$

$$C = \frac{21}{8}$$

Thus, the function is $y = \frac{x^3}{3} + c$.

$$\text{Use } \int ax^n dx = a \int x^n dx = \frac{ax^{n+1}}{n+1} + c$$

Multiply of fraction/simplify

$$\text{Use } \int x^n dx = \frac{1}{n+1} x^{n+1} + c$$

Substituting $x = 2$ and $y = 7$ to find c **Question 8****Integrate** $\int \left(w + \frac{1}{w} \right) \left(w - \frac{1}{w} \right) dx$

(a) $\frac{w^3}{3} + \frac{1}{w}$

(b) $\frac{w^3}{3} + \frac{1}{w} + c$

(c) $\frac{w}{3} + \frac{1}{w} + c$

(d) None

Answer: b**Explanation:**

$$\int \left(w + \frac{1}{w} \right) \left(w - \frac{1}{w} \right) dw$$

$$= \int \left(w^2 - \frac{1}{w^2} \right) dw$$

$$= \int w^2 dw - \int \frac{1}{w^2} dw$$

$$= \int w^2 dw - \int w^{-2} dw$$

$$= \frac{w^3}{3} + \frac{1}{w} + c$$

Express the product as a difference of two squares

$$\text{Use } \int f(x)dx + g(x)dx = \int f(x)dx + \int g(x)dx$$

Express in negative exponential form

$$\text{Use } \int x^n dx = \frac{1}{n+1} x^{n+1} + c. \text{ Simplify}$$

Question 9**If** $\frac{d^2y}{dx^2} = 10 - 3x$, **find** $\frac{dy}{dx} + c$

(a) $10x - \frac{3}{2}x^2 + c$

(b) $10x - \frac{3}{2} + c$

(c) $10 - \frac{3}{2}x^2 + c$

(d) none

Answer: a**Explanation:**

$$\frac{dy}{dx} = \int (10 - 3x) dx = \int 10 dx - \int 3x dx$$

$$= 10x - \left(\frac{3x^{1+1}}{1+1} \right) + c$$

$$\text{Use } \int f(x)dx + g(x)dx = \int f(x)dx + \int g(x)dx$$

$$\text{Use } \int ax^n dx = a \int x^n dx = \frac{ax^{n+1}}{n+1} + c$$

$$= 10x - \left(\frac{3x^2}{2}\right) + c$$

$$= 10x - \frac{3}{2}x^2 + c$$

Simplify

Question 10Calculate $\int x^7 dx$

(a) $\frac{1}{8}x^7 + c$

(b) $\frac{1}{7}x^7 + c$

(c) $\frac{1}{8}x^8 + c$

(d) None

Answer: c**Explanation:**

$$\int x^7 dx = \frac{1}{7+1}x^{7+1} + c$$

Use $\int x^n dx = \frac{1}{n+1}x^{n+1} + c$ and substitute $n = 7$

$$= \frac{1}{8}x^8 + c$$

Question 11If $\int f(x) dx = xe^{-\log|x|} + f(x)$, then $f(x)$ is

(a) 1

(b) 0

(c) ce^x

(d) $\log x$

Answer: c**Explanation:**

$$\int f(x) dx = xe^{\log\left|\frac{1}{x}\right|} + f(x) \rightarrow \int f(x) dx = \frac{x}{|x|} + f(x)$$

On differentiating both sides, we get

$$F(x) = 0 + f'(x)$$

we know

$$\frac{d}{dx}(e^x) = e^x, \therefore f(x) = ce^x$$

Question 12If $f(t) = \int_{-t}^t \frac{dx}{1+x^2}$, then $f'(1)$ is

(a) 0

(b) $\frac{2}{3}$

(c) -1

(d) 1

Answer: d**Explanation:**

$$\text{Given } f(t) = \int_{-t}^t \frac{dx}{1+x^2} = [\tan^{-1}x]_{-t}^t = 2 \tan^{-1}t$$

$$\text{Differentiating with respect to } f'(t) = \frac{2}{1+t^2}$$

$$f'(1) = \frac{2}{2} = 1$$

Question 13

The existence of first order partial derivatives implies continuity

- (a) True (b) False
(c) Not sure (d) Invalid Question

Answer: b

Explanation:

The mere existence cannot be declared as a condition for continuity because the second order derivatives should also be continuous.

Question 14

Eight guests have to be seated 4 on each side of a long rectangular table. 2 particular guests desire to sit on one side of the table and 3 on the other side. The number of ways in which the sitting arrangements can be made is:

- (a) 1732 (b) 1728
(c) 1730 (d) 1278

Answer: b

Explanation:

Let the two particular guests sit on right side.

So the three particular guests will sit on left side.

So remaining will be 3 people which need to be selected.

From these 3 people 2 will sit on right side and the one will sit on left side.

Total ways of arranging the people will be =

$${}^3C_2 \times {}^1C_1 = 3$$

Total ways of arranging the people will be =

$$\text{Selection of remaining} \times 4! \text{ (For arranging people on left side)} \times 4! \text{ (Arranging people on right side)} = 3 \times 24 \times 24 = 3 \times 756 = 1728$$

So in 1728 ways we can arrange them

Question 15

If $f(x) = x^k$ and $f'(1) = 10$, then the value of k is

- (a) 10 (b) -10
(c) $\frac{1}{10}$ (d) None

Answer: a

Explanation:

$$F(x) = x^k$$

$$F(1) = f(1) = k \times 1$$

$$10 = k \times 1$$

$$K = 10$$

Question 16

The points of discontinuity of the function, $f(x) = \frac{x^2+2x+5}{x^2-3x+2}$ are

(a) $x=0, x=1$

(b) $x=1, x=2$

(c) $x=0, x=2$

(d) None

Answer: b**Explanation:**

$$f(x) = \frac{x^2+2x+5}{x^2-3x+2}$$

Denominator = 0

$$X^2 - 3x + 2 = 0$$

$$(x-1)(x-2) = 0$$

$$X = 1, x = 2$$

Question 17

The gradient of a function is parallel to the velocity vector of the level curve

(a) True

(b) False

(c) Not sure

(d) Invalid questions

Answer: b**Explanation:**

The gradient is perpendicular and not parallel to the velocity vector of the level curve.

Question 18

$$y = (8 + x^3) (x^3 - 8)$$

(a) $6x^5$

(b) x^5

(c) $6x$

(d) None

Answer: a**Explanation:**

This problem is solvable as a product but if you realize that you are looking at a difference of two squares, it because very simple.

$$Y = (8 + x^3) (x^3 - 8) = x^6 - 64$$

$$\frac{dy}{dx} = 6x^5$$

Question 19

If $(x, y, z, t) = xy + zt + x^2 y z t$; $x = k^3$; $y = k^2$; $z = k$; $t = \sqrt{k}$

Find $\frac{df}{dt}$ at $k = 1$

- (a) 34 (b) 16
(c) 32 (d) 61

Answer: b

Explanation:

Using chain rule we have

$$\begin{aligned} \frac{df}{dt} &= f_x \frac{dx}{dk} + f_y \frac{dy}{dk} + f_z \frac{dz}{dk} + f_t \frac{dt}{dk} \\ &= (y + 2xyzt).(3k^2) + (x + x^2zt).(2k) + (t + x^2yt).(1) + (z + x^2yz).\left(\frac{1}{2\sqrt{k}}\right) \end{aligned}$$

Put $k = 1$; we have $x=y=z=t=1$

$$9 + 4 + 2 + 1 = 16.$$

Question 20

If $(x, y) = x^2 + y^3$; $x = t^2 + t^3$; $y = t^3 + t^9$ find $\frac{df}{dt}$ at $t=1$.

- (a) 0 (b) 1
(c) -1 (d) 164

Answer: d

Explanation:

Using chain rule we have

$$\begin{aligned} \frac{df}{dt} &= f_x \frac{dx}{dt} + f_y \frac{dy}{dt} \\ x &= (2x).(2t + 3t^2) + (3y^2).(3t^2 + 9t^8) \end{aligned}$$

Put $t = 1$; we have $x = 2$; $y = 2$

$$= 4.(5) + 12.(12) = 164.$$

Question 21

$f(x, y) = x^2 + xyz + z$ find f_x at $(1, 1, 1)$

- (a) 0 (b) 1
(c) 3 (d) -1

Answer: c

Explanation:

$$F_x = 2x + yz$$

Put $(x, y, z) = (1, 1, 1)$

$$F_x = 2 + 1 = 3.$$

Question 22

Necessary condition of Euler's theorem is

- (a) z should be homogenous and of order n
 (b) x should not homogeneous but for order n
 (c) Should be implicit
 (d) should be the function of x and y only

Answer: a

Explanation:

Of x and y of order 'n' then $x \frac{dz}{dx} + y \frac{dz}{dy} = nz$

Answer 'b' is incorrect as z should be homogeneous.

Answer 'c' is incorrect as z should not be implicit.

Answer 'd' is incorrect as z should be the homogeneous function of x and y not non-homogeneous functions.

Question 23

If $f(x, y) = \frac{x+y}{y}$, $x \frac{dz}{dx} + y \frac{dz}{dy} = ?$

- (a) 0
 (b) 1
 (c) 2
 (d) 3

Answer: a

Explanation:

Given function $f(x, y) = \frac{x+y}{y}$ can be written as $f(x, y) = \frac{[1+\frac{y}{x}]}{\frac{y}{x}} = x^0 f\left(\frac{y}{x}\right)$,

Hence by Euler's theorem.

$$x \frac{dz}{dx} + y \frac{dz}{dy} = 0$$

Question 24

Find the approximate value of $[0.982 + 2.012 + 1.942]^{1/2}$

- (a) 1.96
 (b) 2.96
 (c) 0.04
 (d) -0.04

Answer: b

Explanation:

Let $f(x, y, z) = (x^2 + y^2 + z^2)^{\frac{1}{2}}$ (1)

Hence, $x = 1, y = 2, z = 2$, so that $dx = -0.02, dy = 0.01, dz = -0.06$

From (1)

$$\frac{df}{dx} = \frac{x}{f}$$

$$\frac{df}{dy} = \frac{y}{f}$$

$$\frac{df}{dz} = \frac{z}{f}$$

$$df = \frac{df}{dx}dx + \frac{df}{dy}dy + \frac{df}{dz}dz = \frac{(xdx+yd y+zd z)}{f} = \frac{-0.02+0.01-0.12}{3} = -0.04$$

$$[0.98^2 + 2.01^2 + 1.94^2]^{1/2} = f(1, 2, 2) + df = 3 - 0.04 = 2.96$$

Question 25

$f(x,y) = \frac{x^3+y^3}{x^{99}+y^{98}x+y^{99}}$ find the value of f_y at $(x, y) = (0, 1)$

- (a) 101 (b) -96
(c) 210 (d) 0

Answer: b**Explanation:**

Using Euler theorem

$$Xf_x + yf_y = n f(x, y)$$

Substituting $x = 0$; $n = -96$ and $y = 1$ we have

$$F_y = -96. F(0, 1) = -96.(1 / 1)$$

$$= -96$$

Question 26

$f(x, y) = x^3 + xy^2 + 901$ satisfies the Eulers theorem

- (a) True (b) False
(c) Not sure (d) Invalid questions

Answer: b**Explanation:**

The function is not homogenous and hence does not satisfy the condition posed by Euler's theorem.

Question 27

For a homogenous function if critical points exist the value at critical points is

- (a) 1 (b) equal to its degree
(c) 0 (d) -1

Answer: c

For a homogeneous function if critical points exist the value at critical points is? $f(a, b) = 0(a, b) \rightarrow$ critical points. $nf(a, b) = 0 \Rightarrow f(a, b) = 0(a, b) \rightarrow$ critical points. Explanation: Euler's theorem is nothing but the linear combination asked here, The degree of the homogeneous function can be a real number.

Question 28

$\lim_{n \rightarrow \infty} \left[\frac{n}{1+n^2} + \frac{n}{4+n^2} + \frac{n}{9+n^2} + \dots + \frac{1}{2n} \right]$ is equal to

- (a) $\frac{\pi}{2}$ (b) $\frac{\pi}{4}$
(c) 1 (d) None of these

Answer: d**Explanation:**

$$\begin{aligned}
& \text{We have } \lim_{n \rightarrow \infty} \left[\frac{n}{1+n^2} + \frac{n}{4+n^2} + \dots + \frac{1}{2n} \right] \\
&= \lim_{n \rightarrow \infty} \sum_{r=1}^n \frac{n}{r^2+n^2} = \lim_{n \rightarrow \infty} \sum_{r=1}^n \frac{n}{n^2 \left(1 + \frac{r^2}{n^2}\right)} \\
&= \lim_{n \rightarrow \infty} \sum_{r=1}^n \frac{1}{n \left(1 + \frac{r^2}{n^2}\right)} = \int_0^1 \frac{dx}{1+x^2} \\
&\left\{ \text{Applying formula, } \lim_{n \rightarrow \infty} \sum_{r=0}^{n-1} \left\{ f\left(\frac{r}{n}\right) \right\} \cdot \frac{1}{n} = \int_0^1 f(x) dx \right\} \\
&= [\tan^{-1}x]_0^1 = \tan^{-1} 1 - \tan^{-1} 0 = \frac{\pi}{4}.
\end{aligned}$$

Question 29

For homogenous function with no saddle points we must have the minimum value as

- (a) 90 (b) 1
(c) Equal to degree (d) 0

Answer: d

Explanation:

Substituting $f_x = f_y = 0$ At critical in euler's theorem we have
 $nf(a, b) = 0 \rightarrow f(a, b) = 0(a, b) \rightarrow$ critical points.

Question 30

The derivatives of $f(x) = \int_{x^2}^{x^3} \frac{1}{\log t} dt$, ($x > 0$) is

- (a) $\frac{1}{3 \log x} - \frac{1}{2 \log x}$ (b) $\frac{1}{3 \log x}$
(c) $\frac{3x^2}{3 \log x}$ (d) $(\log x)^{-1} \cdot x(x-1)$

Answer: d

Explanation:

We know that

$$\frac{d}{dx} \left(\int_a^b f(t) dt \right) = \frac{db}{dx} f(b) - \frac{da}{dx} f(a)$$

a and b are functions of x

$$\therefore f(x) = \int_{x^2}^{x^3} \frac{1}{\log t} dt$$

$$\begin{aligned}
F'(x) &= \frac{d}{dx} (x^3) \frac{1}{\log x^3} - \frac{d}{dx} (x^2) \frac{1}{\log x^2} \\
&= \frac{3x^2}{3 \log x} - \frac{2x}{2 \log x} = x(x-1)(\log x)^{-1}
\end{aligned}$$

Question 31

The greatest value of the function $f(x) = \int_1^x |t| dt$ on the interval $[-\frac{1}{2}, \frac{1}{2}]$ is given by?

- (a) $\frac{3}{8}$ (b) $-\frac{1}{2}$
 (c) $-\frac{3}{8}$ (d) $\frac{2}{5}$

Answer: c

Explanation:

$f'(x) = |x| > 0 \forall x \in [-\frac{1}{2}, \frac{1}{2}]$ hence the

Function is increasing on $[-\frac{1}{2}, \frac{1}{2}]$ and therefore $f(x)$ has

Maximum at the right point of $[-\frac{1}{2}, \frac{1}{2}]$

$$\text{Max } f(x) = f\left(\frac{1}{2}\right) = \int_1^{\frac{1}{2}} |t| dt = -\frac{3}{8}$$

Question 32

For homogenous function the linear combination of rates of independent change along x and y axis is

- (a) Integral multiple function value (b) no relation to function value
 (c) real multiple of function value (d) depends if the function is a polynomial

Answer: c

Explanation:

Euler's theorem is nothing but the linear combination asked here, The degree of the homogeneous function can be a real number. Hence, the value is integral multiple of real number.

Question 33

$$\int_0^{b-c} f^n(x+a) dx =$$

- (a) $f'(a) - f'(b)$ (b) $f'(b-c+a) - f'(a)$
 (c) $f'(b+c-a) + f'(a)$ (d) None of these

Answer: b

Explanation:

$$\int_0^{b-c} f^n(x+a) dx$$

$$= [f'(x+a)]_0^{b-c} = f'(b-c+a) - f'(a)$$

Question 34

$$\int_0^x \frac{x^3 dx}{(x^2+4)^2} =$$

- (a) 0 (b) ∞
 (c) 1/2 (d) None of these

Answer: b**Explanation:**

$$\begin{aligned} \int_0^{\infty} \frac{x^3 dx}{(x^2+4)^2} &= \frac{1}{2} \int_0^{\infty} \frac{2x^2 dx}{(x^2+4)^2} dx \\ &= 2 \int_0^{\infty} \frac{t}{(t+4)^2} dt, \quad [\text{Putting } x^2=t] \\ &= 2 \int_0^{\infty} \left[\frac{1}{t+4} - \frac{4}{(t+4)^2} \right] dt = \frac{1}{2} \left[\log(t+4) + \frac{4}{t+4} \right]_0^{\infty} \\ &= \frac{1}{2} [\log \infty + 0 - (\log 4 + 1)] = \infty \end{aligned}$$

Question 35

The points of intersection of $F_1(x) = \int_2^x (2t - 5) dt$ and $f_2(x) = \int_0^x 2t dt$, are

- (a) $\left(\frac{6}{5}, \frac{36}{25}\right)$ (b) $\left(\frac{2}{3}, \frac{4}{5}\right)$
 (c) $\left(\frac{1}{3}, \frac{3}{6}\right)$ (d) $\left(\frac{5}{4}, \frac{5}{7}\right)$

Answer: a**Explanation:**

Let $f_1(x) = y_1 = \int_2^x (2t - 5) dt$ and

$F_2(x) = y_2 = \int_0^x 2t dt$ now point of intersection means those those point at which

$x^2 = x^2 - 5x + 6 \Rightarrow x = \frac{6}{5}$ and $y = x^2 = \frac{36}{25}$ thus point of

Intersection is $\left(\frac{6}{5}, \frac{36}{25}\right)$

Question 36

The solution of the equation $\frac{x^2 d^2 y}{dx^2} = \ln x$, when $x=1, y=0$ and $\frac{dy}{dx} = -1$

- (a) $\frac{1}{2}(\ln x)^2 + \ln x$ (b) $\frac{1}{2}(\ln x)^2 - \ln x$
 (c) $-\frac{1}{2}(\ln x)^2 + \ln x$ (d) $-\frac{1}{2}(\ln x)^2 - \ln x$

Answer: d**Explanation:**

$$\frac{d^2 y}{dx^2} = \frac{\log x}{x^2} \rightarrow \frac{-(\log x + 1)}{x} + c$$

$$\text{At } \frac{dy}{dx} = -\int \frac{\log x + 1}{x} dx = -\frac{1}{2}(\log x)^2 - \log x$$

Question 37

The rate of increase of bacteria in a certain culture is proportional to the number present. If it double 5 hours then in 25 hours its number would be

- (a) 8 times the original (b) 16 times the original
 (c) 32 times the original (d) 64 times the original

Answer: c

Explanation:

Let P_0 be the initial population and let the

Population after t years be P . then $\frac{dp}{dt} = KP \rightarrow \frac{dP}{P} = kdt$

On integrating, we have $\log P = kt + c$ At $t = 0$,

$P = P_0 \therefore \log P_0 = 0 + C, \therefore \log P = kT + \log P_0$

$\log \frac{P}{P_0} = kt$ when $t = 5$ hrs, $P = 2P_0 \therefore$

$\log \frac{2P}{P_0} = 5k \therefore k = \frac{\log 2}{5} \therefore \log \frac{P}{P_0} = \frac{\log 2}{5}t$ when

$T = 25$ hours, we have

$\log \frac{P}{P_0} = \frac{\log 2}{5} \times 25 = 5 \log 2 = \log 32; \therefore P = 32P_0.$

Question 38

The degree of the $3\frac{d^2y}{dx^2} = \left\{1 + \left(\frac{dy}{dx}\right)^2\right\}^{\frac{3}{2}}$ is differential equation

(a) 1

(b) 2

(c) 3

(d) 6

Answer: b

Explanation:

$3\frac{d^2y}{dx^2} = \left\{1 + \left(\frac{dy}{dx}\right)^2\right\}^{\frac{3}{2}}$ on squaring, we

Get $9\left(\frac{d^2y}{dx^2}\right)^2 = \left\{1 + \left(\frac{dy}{dx}\right)^2\right\}^3$ obviously the

Highest derivatives $\frac{d^2y}{dx^2}$ contains a degree 2.

Question 39

The differential equation representing the family of curves $y^2 = 2c(x + \sqrt{c})$, where c is a positive perimeter, is of

(a) Order 1

(b) Order 2

(c) Degree 3

(d) Degree 4

Answer: a

Explanation:

Given family of curves

$y^2 = 2c(x + \sqrt{c}), \dots (i)$

On differentiating both sides, we get

$2y\frac{dy}{dx} = 2c(1 + 0) \rightarrow c = y\frac{dy}{dx}$

From equation (i), we have

$y^2 = 2y\frac{dy}{dx}\left\{x + \left(y\frac{dy}{dx}\right)^{1/2}\right\}$

$\rightarrow \left(y^2 - 2xy\frac{dy}{dx}\right) = 2\left(y\frac{dy}{dx}\right)^{3/2}$

On squaring both sides, we get

$$\left(y^2 - 2xy \frac{dy}{dx}\right)^2 = 4 \left(y \frac{dy}{dx}\right)^3$$

So,

Order = 1 (order of a differential equation is the order of the highest derivative (also known as differential coefficient) present in the equation)

Degree = 3 (The degree of differential equation is represented by the power of the highest order derivative in the given differential equation)

Question 41

The order and degree of the differentiate equations $\left(1 + 3 \frac{dy}{dx}\right)^{\frac{2}{3}} - 4 \left(\frac{d^3y}{dx^3}\right)$ are

(a) $1, \frac{2}{3}$

(b) 3, 1

(c) 3, 3

(d) 1, 2

Answer: c

Explanation:

To check, order and degree, the given differential equation should be free from radicals, hence taking cube on both sides,

$$\left(1 + 3 \cdot \frac{dy}{dx}\right)^2 = \left(4 \cdot \frac{d^3y}{dx^3}\right)^3$$

Order = 3, degree = 3.

Question 42

The solution of the differential equation $y - x \frac{dy}{dx} = a \left(y^2 + \frac{dy}{dx}\right)$ is

(a) $y=c(x+a) (1+ay)$

(b) $y=c(x+a) (1 - ay)$

(c) $y=c(x-a) (1+ay)$

(d) None of these

Answer: b

Explanation:

$$Y - x \frac{dy}{dx} = a \left(y^2 + \frac{dy}{dx}\right)$$

$$Y - ay^2 = (x+a) \frac{dy}{dx} \quad \frac{dy}{y(1-ay)} = \frac{dx}{x+a}$$

On integrating both sides, we get

$$\text{Log } y - \log(1 - ay) = \log(x + a) + \log c$$

$$\frac{y}{(1-ay)} = c(x + a) \text{ or } c(x + a)(1 - ay) = y.$$

Question 43

Compute the sum of 4 digit numbers which can be formed with four digit 1, 3, 5, 7 if each digit is used once in each engagement:

(a) 106646

(b) 106636

(c) 106666

(d) None of these

Answer: d**Explanation:**

The number of arrangements of 4 different digits taken 4 at a time is given by ${}^4P_4 = 4! = 24$. All the four digits will occur equal number of times at each of the positions, namely ones, tens, hundreds, thousands.

Thus, each digit will occur $\frac{24}{4} = 6$ times in each of the positions. The sum of digits in one's position will be $6 \times (1+3+5+7) = 96$. Similar is the case in ten's, hundred's and thousand's places.

Therefore, the sum will be $96 + 96 \times 10 + 96 \times 100 = 106656$

PAST EXAMINATION QUESTIONS:

MAY 2018

Question 1

The value of $\int_1^2 \frac{1-x}{1+x} dx$ is equal to:

(a) $\log_2^3 - 1$

(b) $2\log_2^3 - 1$

(c) $\frac{1}{2} \log_2^3$

(d) $\frac{1}{2} \log_2^3 - 1$

Answer: b**Explanation:**

$$\int_1^2 \left(\frac{1-x}{1+x} \right) dx = \int_1^2 \left(\frac{1}{1+x} - \frac{x}{1+x} \right) dx$$

$$\int_1^2 \frac{1}{1+x} dx - \int_1^2 \frac{x}{x+1} dx$$

$$\int_1^2 \frac{1}{1+x} dx - \int_1^2 \left(\frac{1+x-1}{1+x} \right) dx$$

$$\int_1^2 \frac{1}{(1+x)} dx - \int_1^2 \left(\frac{1}{1+x} \right) dx$$

$$\int_1^2 \frac{1}{1+x} dx - \int_1^2 1 \times dx + \int_1^2 \frac{1}{1+x} dx$$

$$2 \int_1^2 \frac{1}{1+x} - \int_1^2 1 dx$$

$$2[\log(1+x)]_1^2 - [x]_1^2$$

$$2[\log(2+1) - \log(1+1)] - [2-1]$$

$$2[\log 3 - \log 2] - 1$$

$$2 \log_2^3 - 1$$

Question 2

$\int_0^2 \frac{3\sqrt{x}}{\sqrt{x}}$ is equal to

(a) $\frac{\sqrt[2]{2}}{\log_e 3}$

(b) 0

(c) $\frac{2(3\sqrt{2}-1)}{\log_e 3}$

(d) $\frac{3\sqrt{2}}{\sqrt{2}}$

Answer: c

Explanation:

$$\int_0^2 \frac{3^{\sqrt{x}}}{\sqrt{x}} dx$$

Let $\sqrt{x} = t$

$$\int_0^2 3^{\sqrt{x}} \cdot \frac{1}{\sqrt{x}} dx \cdot \frac{1}{2\sqrt{x}} dx = dt$$

$$\frac{1}{\sqrt{x}} dx = 2dt$$

x	0	2
t	0	$\sqrt{2}$

$$\int_0^{\sqrt{2}} 3^t \cdot 2dt$$

$$\int_0^{\sqrt{2}} 3^t dt$$

$$2 \left[\frac{3^t}{\log 3} \right]_0^{\sqrt{2}}$$

$$2 \left[\frac{3^{\sqrt{2}}}{\log 3} - \frac{3^0}{\log 3} \right]$$

$$\frac{2(3^{\sqrt{2}} - 3^0)}{\log_e 3}$$

Question 3

The value of $\int_0^2 \frac{\sqrt{x}}{\sqrt{x} + \sqrt{2-x}} dx$ is:

(a) 0

(b) 3

(c) 2

(d) 1

Answer: d

Explanation:

$$\int_0^2 \frac{\sqrt{x}}{\sqrt{x} + \sqrt{2-x}} dx \dots\dots\dots(1)$$

$$I = \int_0^2 \frac{\sqrt{0+2-x}}{\sqrt{0+2-x} + \sqrt{2-(0+2-x)}} dx$$

$$\left[\int_a^b f(x) dx = \int_a^b f(a+b-x) dx \right]$$

$$I = \int_0^2 \frac{\sqrt{2-x}}{\sqrt{2-x} + \sqrt{x}} dx \dots\dots\dots(2)$$

Apply (1) and (2) we get

$$2I = \int_0^2 \left[\frac{\sqrt{x}}{\sqrt{x} + \sqrt{2-x}} + \frac{\sqrt{2-x}}{\sqrt{2-x} + \sqrt{x}} \right] dx$$

$$2I = \int_0^2 \frac{(\sqrt{x} + \sqrt{2-x})}{(\sqrt{x} + \sqrt{2-x})} dx$$

$$2I = \int_0^2 1 dx$$

$$2I = [X]_0^2$$

$$2I = [2 - 0]$$

$$2I = 2$$

$$I = \frac{2}{2}$$

$$I = 1$$

Question 4

$$\lim_{X \rightarrow 1} \frac{x + x^2 + x^3 \dots \dots + x^n - n}{x - 1}$$

(a) n

(b) $\frac{n(n+1)}{2}$

(c) (n + 1)

(d) n(n + 1)

Answer: b**Explanation:**

$$\lim_{X \rightarrow 1} \frac{x + x^2 + x^3 \dots \dots + x^n - n}{x - 1} \quad (\because)$$

By L.H. Rule

$$= \lim_{x \rightarrow 1} \frac{d/dx(x + x^2 + x^3 \dots \dots + x^n - n)}{d/dx(x - 1)}$$

$$= \lim_{x \rightarrow 1} \frac{1 + 2x + 3x^2 + \dots \dots + nx^{n-1} - 0}{1 - 0}$$

$$= \frac{1 + 2 \times 1 + 3(1)^2 + \dots \dots + n(1)^{n-1}}{1}$$

$$= 1 + 2 + 3 + \dots \dots n$$

$$= \sum_{n=1}^n \frac{n(n+1)}{2}$$

Question 5

The cost function for the production of x unit of a commodity is given by $C(x) = 2x^3 + 15x^2 + 36x + 15$

(a) 3

(b) 2

(c) 1

(d) 4

Answer: a**Explanation:**

The cost function given by $C(x) = 2x^3 + 15x^2 + 36x + 15$

$$\frac{d}{dx} C(x) = 6x^2 - 30x + 36 \dots \dots (1)$$

$$C(x) = 0$$

$$6x^2 - 30x + 36 = 0$$

$$6(x^2 - 5x + 6) = 0$$

$$= x^2 - 5x + 6 = 0$$

$$= x^2 - 3x - 2x + 6 = 0$$

$$= x(x-3) - 2(x-3) = 0$$

$$(x-3)(x-2) = 0$$

$$X = 3, 2$$

Differentiating equations (2) again w.r.f. 'x'

$C(x) = 12x - 30$ Eq (3)
 Putting $(x = 2)$ in
 $C(x) = 12 \times 2 - 30 = -6$
 Putting $(x=3)$ in
 $C(x) = 12 \times 3 - 30 = 6(+ve)$ so function is minimum at $x=3$

Question 6

$$\lim_{x \rightarrow 0} \frac{2e^{\frac{1}{x}} - 3x}{e^{\frac{1}{x} + x}}$$

(a) -3

(b) 0

(c) 2

(d) 9

Answer: C

Let $\frac{1}{x} = y$ if $x \rightarrow 0, y \rightarrow \infty$

$$\lim_{x \rightarrow \infty} \frac{2e^y - 3\frac{1}{y}}{e^{y + \frac{1}{y}}}$$

$$= \lim_{x \rightarrow \infty} \frac{2 - 3\frac{1}{\infty \cdot e^{\infty}}}{1 + \frac{1}{\infty \cdot e^{\infty}}}$$

$$= \frac{2 - 0}{1 + 0} = 2$$

NOV 2018**Question 1**

Let $x = at^3, y = \frac{a}{t^2}$. Then $\frac{dy}{dx} =$

(a) $\frac{-1}{t^6}$ (b) $\frac{-3a}{t^6}$ (c) $\frac{1}{3at^6}$

(d) None

Answer: d**Explanation:**

If $x = at^3, y = \frac{a}{t^2} = at^{-2}$

Given $x = at^3$

Different w.r.t. (t)

$$\frac{dy}{dx} = \frac{d}{dt} at^3 = a \cdot 3t^2 = 3at^2$$

and $y = at^{-2}$

$$\frac{dy}{dx} = \frac{\frac{dy}{dt}}{\frac{dx}{dt}} = \frac{-2at^{-3}}{3at^2} = \frac{-2}{3t^5}$$

Question 2

$\int x(x^2 + 4)^5 dx$ is equal to

(a) $(x^2 + 4)^6 + c$

(b) $\frac{1}{12}(x^2 + 4)^6 + c$

(c) $\frac{1}{6}(x^2 + 4)^6 + c$

(d) None

Answer: b**Explanation:**

$$\int x(x^2 + 4)^5 = x$$

Let $x^2 + 4 = t$

$$2x dx = dt$$

$$x dx = \frac{dt}{2}$$

$$\int (x^2 + 4)^5 \cdot x dx$$

$$\int t^5 \cdot \frac{dt}{2}$$

$$= \frac{1}{2} \int t^5 dt$$

$$= \frac{1}{2} \frac{t^6}{6} + c$$

$$= \frac{1}{12}(x^2 + 4)^6 + c$$

Question 3

$xy = 1$ then $y^2 + \frac{dy}{dx} = ?$

(a) 1

(b) 0

(c) 2

(d) None

Answer: b**Explanation:**

Given : $xy = 1$

To find: $y^2 + \frac{dy}{dx} = ?$

$$xy = 1$$

$$x = \frac{1}{y}$$

Differentiate w.r.t x

$$1 = -\frac{1}{y^2} \cdot \frac{dy}{dx} \quad (\text{chain rule})$$

$$y^2 = -\frac{dy}{dx}$$

$$y^2 + \frac{dy}{dx} = 0$$

Hence, the value of given differential equation is 0

Question 4

$\int_{-1}^3 (1 + 3x + x^3) dx$ is equal to

(a) -4

(b) 4

(c) 3

(d) -3

Answer: a

$$\int_{-1}^3 (1 + 3x + x^3) dx$$

$$\int_{-1}^3 1 dx + \int_{-1}^3 3x dx - \int_{-1}^3 x^3 dx$$

$$[x]_{-1}^3 + 63 \left[\frac{x^2}{2} \right]_{-1}^3 - \left[\frac{x^4}{4} \right]_{-1}^3$$

$$[3 - (-1)] + \frac{3}{2} [(3)^2 - (-1)^2] - \frac{1}{4} [(3)^4 - (-1)^4]$$

$$(3+1) + \frac{3}{2} [9 - 1] - \frac{1}{4} [81 - 1]$$

$$4 + \frac{3}{2} \times 8 - \frac{1}{4} \times 80$$

$$4 + 12 - 20 = -4$$

MAY 2019

Question 1

If $2^x - 2y = 2^{x-y}$ then $\frac{dy}{dx}$ at $x = y = 2$

(a) 1

(b) 2

(c) 4

(d) 5

Answer: a**Explanation:**

$$2^x - 2y = 2^{x-y} \quad x = y = 2 \frac{dy}{dx}$$

$$2^x \cdot \text{Log}^2 - 2y \cdot \text{log}^2 \cdot \frac{dy}{dx} = 2^{x-y} \cdot \text{Log}^2 \left[1 - \frac{dy}{dx} \right]$$

$$\text{Log}^2 [2^x - 2y \cdot \frac{dy}{dx}] = \text{Log}^2 [2^{x-y} (1 - \frac{dy}{dx})]$$

$$2^2 - 2 \cdot 2 \cdot \frac{dy}{dx} = 2^0 \left[1 - \frac{dy}{dx} \right]$$

$$4 - 4 \cdot \frac{dy}{dx} = 1 - \frac{dy}{dx}$$

$$4 - 1 = 4 \frac{dy}{dx} - \frac{dy}{dx}$$

$$3 = 3 \frac{dy}{dx}$$

$$\frac{dy}{dx} = 1$$

Question 2

If the cost of function of a commodity is given by $C = 150x - 5x^2 + \frac{x^3}{6}$, where C stands for cost and x stands for output. If the average cost is equal to the marginal cost then the output $x =$ _____

- (a) 5 (b) 10
(c) 15 (d) 20

Answer: c**Explanation:**

$$\text{Average cost} = \frac{\text{Totalcost}}{\text{output}}$$

$$C = 150x - 5x^2 + \frac{x^3}{6}$$

$$\frac{c}{\text{output}} = \frac{150x}{x} - \frac{5x^2}{x} + \frac{\frac{x^3}{6}}{x}$$

$$C = 150 - 5x + \frac{x^2}{6}$$

$$\frac{dc}{dx} = -5 + \frac{2x}{6}$$

$$-5 + \frac{x}{3} = 0$$

$$75 + x = 0$$

$$X = 15$$

Question 3

$$\int_2^3 \frac{\sqrt{x}}{\sqrt{5-x} + \sqrt{x}} dx =$$

- (a) 1 (b) $\frac{1}{2}$
(c) 2 (d) $\frac{3}{2}$

Answer: b**Explanation:**

$$\text{Let } I = \int_2^3 \frac{\sqrt{x}}{\sqrt{5-x} + \sqrt{x}} dx \quad \text{----- (1)}$$

$$\text{Using } \int_a^b f(x) dx = \int_a^b f(a+b-x) dx$$

$$\therefore I = \int_2^3 \frac{\sqrt{5-x}}{\sqrt{5-(5-x)} + \sqrt{5-x}} dx \quad \text{----- (2)}$$

$$I = \int_2^3 \frac{\sqrt{5-x}}{\sqrt{x} + \sqrt{5-x}} dx$$

Adding (1) and (2)

$$2I = \int_2^3 \frac{\sqrt{x} + \sqrt{5-x}}{\sqrt{x} + \sqrt{5-x}} dx$$

$$= \int_2^3 1 \cdot dx$$

$$= [x]_2^3$$

$$2I = 3 - 2$$

$$I = \frac{1}{2}$$

Question 4

$$\int \log_e (a^x) dx =$$

- (a) $\log_e a \left[\frac{x^2}{2} \right] + c$ (b) $\log_e a \left[\frac{x}{2} \right] + c$
 (c) $x \log_e a^x - x + c$ (d) None of these

Answer: a**Explanation:**

$$\int \log_e (a^x) dx$$

By option method: Base method

Differentiate option a

$$\log_e a \left[\frac{x^2}{2} \right]$$

$$\frac{1}{a \left[\frac{x^2}{2} \right]} \times a \left[\frac{x^2}{2} \right] \cdot \log_e a \cdot x \times \frac{2x}{2}$$

$$= x \cdot \log_e a$$

$$= \log_e \frac{a^x}{e}$$

NOV 2019**Question 1**

$$\int a^x dx.$$

- (a) $x^x(1 + \log x)$ (b) $1 + \log x$
 (c) $x \cdot \log x$ (d) $\frac{a^x}{\log a} + c$

Answer: d**Explanation:**

(d) Since, we know that

$$\frac{d}{dx} \frac{a^x}{\log a} = a^x$$

$$\int a^x dx = \frac{a^x}{\log a} + c$$

Question 2

$$\int x \cdot e^x dx.$$

- (a) $e^x (1 + \log x)$ (b) $x e^x - e^x + C$
 (c) $\log x + e^x + c$ (d) $\frac{x^2}{e^x} + c$

Answer: b**Explanation:**

Consider the given integral

$$I = \int x e^x dx$$

We know that

$$\int uv dx = u \int v dx - \int \left(\frac{d}{dx} u \int v dx \right) dx$$

Therefore,

$$I = xe^x - \int 1 \cdot e^x dx$$

$$I = xe^x - \int e^x dx$$

$$I = xe^x - e^x + C$$

Hence, this is the answer

Question 3

$$\int (4x + 3)^6 dx.$$

$$(a) \frac{1}{28} (4x + 3)^7 + c$$

$$(b) \frac{1}{7} (4x + 3)^7 + c$$

$$(c) \frac{1}{6} (4x + 3)^6 + c$$

$$(d) \frac{4x}{5} + \frac{3}{5} + c$$

Answer: a

Explanation:

$$(a) \int (4x + 3)^6 dx$$

$$\text{Since, } \int x^n dx = \frac{x^{n+1}}{n+1} + c$$

$$\int (ax + b)^n dx = \frac{(ax+b)^{n+1}}{(n+1)a} + c$$

So,

$$\int (4x + 3)^6 dx$$

$$= \frac{(4x+3)^{6+1}}{(6+1)4} + c$$

$$= \frac{1}{28} (4x + 3)^7 + c$$

Question 4

$$\int_{-1}^1 (2x^2 - x^3) dx$$

$$(a) \frac{4}{3}$$

$$(b) 1$$

$$(c) 2$$

$$(d) \frac{2}{3}$$

Answer: a

Explanation:

$$(a) \int_{-1}^1 (2x^2 - x^3) dx$$

$$= \left[2 \times \frac{x^3 - x^4}{3 \cdot 4} \right]_{-1}^1$$

$$= \left[\left(\frac{2}{3} \times 1^3 - \frac{1^4}{4} \right) - \left\{ \frac{2}{3} \times (-1)^3 - \frac{(-1)^4}{4} \right\} \right]$$

$$= \left[\left(\frac{2}{3} - \frac{1}{4} \right) - \left(\frac{-2}{3} - \frac{1}{4} \right) \right]$$

$$= \frac{2}{3} - \frac{1}{4} + \frac{2}{3} + \frac{1}{4}$$

$$= \frac{4}{3}$$

Question 5

$$\frac{d}{dx}(x \cdot \log x)$$

(a) $x(1 + \log x)$

(b) $1 + \log x$

(c) $e^x x \cdot \log x$

(d) $x^2 (\log x)$

Answer: b**Explanation:**

(b) $\frac{d}{dx}(x \cdot \log x)$

Since $\frac{d}{dx}(u \cdot v) = u \frac{d}{dx}(v) + v \frac{d}{dx}(u)$

So here $u \Rightarrow x$

$v \Rightarrow \log x$

$\therefore \frac{d}{dx}(x \cdot \log x)$

$= x \cdot \frac{d}{dx}(\log x) + \log x \times \frac{d}{dx}(x)$

$= x \cdot \frac{1}{x} + \log x \times 1$

$= 1 + \log x$

Question 6**Differentiate x^x w.r.t x .**

(a) $x^x(1 + \log x)$

(b) $\frac{y}{x}$

(c) $\frac{-y}{x}$

(d) $y + x^x \log x$

Answer: a**Explanation:**

(a) $\frac{d}{dx}(x^x) = ?$

Let $y = x^x$

Using log both sides

$\log y = x \log x$

On differentiating both sides w.r.t. x

$\frac{1}{y} \cdot \frac{dy}{dx} = x \times \frac{d}{dx}(\log x) + \log x \times \frac{d}{dx}(x)$

$\frac{dy}{dx} = y \left[x \times \frac{1}{x} + \log x \times 1 \right]$

Question 7

$$\int x^2 \cdot e^x dx.$$

(a) $2x \cdot e^x$

(b) $e^x(x^2 - 2x)$

(c) $x^2 \cdot e^x \cdot (2x) + 2$

(d) $e^x(x - 1)$

Answer: b**Explanation:**

$$\int x^2 e^x dx$$

Using I late

$x^2 \Rightarrow$ 1st function (u)

$e^x \Rightarrow$ 2nd function (v)

$$\int u \cdot v dx = u \cdot \int \left[\frac{d}{dx}(u) \cdot \int v dx \right] dx$$

So $\int x^2 e^x dx$

$$x^2 \int e^x dx - \int \left[\frac{d}{dx}(x^2) \int e^x dx \right] dx$$

$$x^2 e^x dx - \int [2x \cdot e^x] dx$$

$$x^2 \cdot e^x - 2x \int x \cdot e^x dx \quad \text{-----Equation (1)}$$

$$= x \cdot \int e^x - \int \frac{d}{dx}(x) \cdot \int e^x dx dx$$

$$= x \cdot e^x - e^x$$

$$= e^x (x - 1) \quad \text{-----Equation (2)}$$

Put Equation (2) in Equation (1)

$$x^2 \cdot e^x - 2 e^x (x-1)$$

$$x^2 \cdot e^x - 2 e^x \cdot x + 2$$

$$= e^x (x^2 - 2x) + 2$$

JULY 2021

Question 1

The value of $\int_{-2}^2 f(x) dx$, where $f(x) = 1+x, x \leq 0$; $f(x) = 1-2x, x \geq 0$ is

(a) 20

(b) -2

(c) -4

(d) 0

Answer: Options (b)

DEC 2021

Question 1

The cost of producing x units is $500-20x^2 + x^3 / 3$. The marginal cost is minimum at x = _____.

(a) 5

(b) 10

(c) 40

(d) 50

Answer: c

Explanation:

Here, cost function is given by

$$c(x) = 500 - 20x^2 + \frac{x^3}{3}$$

Diff. w.r.t. 'x'

$$\frac{d}{dx} c(x) = \frac{d}{dx} \left[500 + 20x^2 + \frac{x^3}{3} \right]$$

$$\frac{dc(x)}{dx} = 0 - 40x + \frac{3x^2}{3}$$

$$\frac{dc}{dx} = (x^2 - 40x)$$

$$\text{Marginal cost} = \frac{dc}{dx}$$

$$= (x^2 - 40x)$$

$$x(x-40) = 0$$

$$\text{If } x=0, \text{ if } x-40 = 0$$

$$x = 40$$

Question 2

If $y = \frac{x^4}{e^x}$ then $\frac{dy}{dx}$ is equal to:

(a) $x^3(4-x) / (e^x)^2$

(b) $x^3(4-x) / e^x$

(c) $x^2(4-x) / e^x$

(d) $x^3(4x-1) / e^x$

Answer: b

Explanation:

$$\text{If } y = \frac{x^4}{e^x}$$

Diff. w.r.t. 'x'

$$\frac{dy}{dx} = \frac{e \times \frac{d}{dx}(x^4) - x^4 \cdot e^x}{(e^x)^2}$$

$$= \left(\frac{e^x \cdot 4x^3 - x^4 \cdot e^x}{e^{2x}} \right)$$

$$= \frac{x^3(4-x)}{e^x}$$

Question 3

The speed of a train at a distance x (from the starting point) is given by $3x^2 - 5x + 4$. What is the rate of change (of distance) at $x=1$?

(a) -1

(b) 0

(c) 1

(d) 2

Answer: c

Explanation:

The speed of a train at a distance x is given by

$$V = 3x^2 - 5x + 4$$

Diff. w.r.t. 'x'

$$\frac{dy}{dx} = 6x - 5$$

$$\left[\frac{dy}{dx} \right]_{x=1} = 6 \times 1 - 5 = 6 - 5 = 1$$

Rate of change (of distance) at $x=1$ is 1.

JUNE 2022

Question 1

$\int_0^1 x e^x dx$ is equal to:

- (a) 0 (b) 2
(c) 1 (d) 3

Answer: Options (c)

Explanation:

$$\int_0^1 x e^x dx$$

$$\left[x \int e^x dx - \int \left(\frac{d}{dx} x \int e^x dx \right) dx \right]_0^1$$

$$= [x e^x - \int 1 \cdot e^x dx]_0^1$$

$$= [x e^x - e^x]_0^1$$

$$= (1 \cdot e^1 - e^1) - (0 \cdot e^0 - e^0)$$

$$= (e - e) - (0 - 1) = 0 + 1 = 1$$

Question 2

What will be $f(x)$ if $f'(x) = 10x^2 + 4x$ and $f(-3) = 17$

- (a) $f(x) = \frac{10x^3}{3} + 2x^2 + 89$ (b) $f(x) = \frac{10x^3}{3} + 2x^2 + 72$
(c) $f(x) = \frac{10x^3}{3} + 2x^2 - 89$ (d) None

Answer: Options (a)

Explanation:

Here $f'(x) = 10x^2 + 4x$
on integration both side

$$\int f'(x) dx = \int (10x^2 + 4x) dx$$

$$f(x) = 10 \frac{x^3}{3} + 4 \frac{x^2}{2} + C \quad (1)$$

$$\text{putting } x = -3, f(-3) = \frac{10(-3)^3}{3} + \frac{4(-3)^2}{2} + C$$

$$17 = \frac{10(-27)}{3} + \frac{4 \times 9}{2} + c$$

$$17 = -90 + 18 + c$$

$$c = 89$$

putting $C = 89$ in eq (1)

$$f(x) = 10 \frac{10x^3}{3} + \frac{4x^2}{2} + 89$$

$$f(x) = 10 \frac{10x^3}{3} + 2x^2 + 89$$

Question 3

$\int (\log x)^2 dx$ is equal to:

- (a) $x(\log x)^2 - 2x \log x + 2x + C$ (b) $x(\log x)^2 + 2x \log x - 2x + C$
(c) $x(\log x)^2 - 2x \log x - x + C$ (d) None

Answer: Options (a)

Explanation:

$$\begin{aligned}
 I &= \int (\log x)^2 dx \\
 &= \int (\log x)^2 \cdot 1 dx \\
 &= (\log x)^2 \cdot \int 1 dx - \int \left(\frac{d}{dx}(\log x)^2\right) \cdot \int 1 dx dx \\
 &= (\log)^2 \cdot x - \frac{2 \log x}{x} \cdot x dx \\
 &= x(\log x)^2 - 2[\log x \int 1 dx - \int \left(\frac{d}{dx} \log x\right) \cdot \int 1 dx dx] \\
 &= x(\log)^2 - 2[\log x \cdot (x) - \int \frac{1}{x} \cdot x dx] \\
 &= x(\log x)^2 - 2[\log x \cdot (X) - \int \frac{1}{x} \cdot x dx] \\
 &= x(\log)^2 - 2[x \log x - x] + C \\
 &= x(\log)^2 - 2x \log x + 2x + C
 \end{aligned}$$

Question 4

The derivative of the function $\sqrt{x + \sqrt{x}}$ is

(a) $\frac{1}{2\sqrt{x+\sqrt{x}}}$

(b) $1 + \frac{1}{2\sqrt{x}}$

(c) $\frac{1}{2\sqrt{x+\sqrt{x}}} \left(1 + \frac{1}{2\sqrt{x}}\right)$

(d) None of these

Answer: Options (c)

Explanation:

$$y = \sqrt{x + \sqrt{x}},$$

Diff w. r. t 'a'

$$\begin{aligned}
 \frac{dy}{dx} &= \frac{d}{dx} (\sqrt{x + \sqrt{x}}) \\
 &= \frac{1}{2\sqrt{x+\sqrt{x}}} \left(1 + \frac{1}{2\sqrt{x}}\right)
 \end{aligned}$$

DEC 2022

Question 1

If $y = x^2$ then dy/dx at $x=1$ is equal to

a) 0

b) 1

c) -1

d) 2

Answer: Options (b)

Question 2

$\int (2x - 3)^5 dx$ is

a) $\frac{(2x-3)^6}{6}$

b) $\frac{(2x-3)^6}{2}$

c) $\frac{(2x-3)^6}{12}$

d) $\frac{(2x-3)^6}{3}$

Question 3

If $x^5 + y^5 = 0$ then $\frac{dy}{dx}$ is

a) $\frac{y+x^4}{x+y^4}$

b) $\frac{y-x^4}{y^4-x}$

c) $\frac{x-y^4}{x^4-y}$

d) $\frac{x+y^4}{x^4+y}$

Answer: Options (b)

Question 4

$\int_x^4 \frac{xdx}{x^2+1}$ is

a) $\frac{1}{2} \log\left(\frac{17}{5}\right)$

b) $2 \log\left(\frac{17}{5}\right)$

c) $\frac{1}{2} \log\left(\frac{5}{17}\right)$

d) $2 \log\left(\frac{5}{17}\right)$

Answer: Options (a)

Question 5

Find the area under the curve $f(x) = x^2 + 5x + 2$ with the limits 0 to 1

a) 3.833

b) 4.388

c) 4.833

d) 3.338

Answer: Options (c)

Question 6

The maxima and minima of the function $y = 2x^3 - 15x^2 + 36x + 10$ occurs respectively at

a) $x=2$ and $x=3$

b) $x=1$ and $x=3$

c) $x=3$ and $x=2$

d) $x=3$ and $x=1$

Answer: Options (C)

Explanation:

$$f(x) = 2x^3 - 15x^2 + 36x + 10 \rightarrow (i)$$

Differentiate w. r to x

$$\Rightarrow f'(x) = 6x^2 - 30x + 36$$

$$\Rightarrow f'(x) = 0$$

$$\Rightarrow 6x^2 - 30x + 36 = 0 \Rightarrow x^2 - 5x + 6 = 0$$

$$\Rightarrow x^2 - 3x - 2x + 6 = 0$$

$$\Rightarrow x(x-3) - 2(x-3) = 0$$

$$\Rightarrow x=3, x=2$$

- (a) 30 (b) 29
(c) 28 (d) 27

Answer: b

Explanation:

$2^3 + 1, 3^3 + 1, 4^3 + 1 \dots$ Here 29 is wrong term of series

Question 3

Find the missing term of the series 1, 9, 25, 49, 81, 121,

- (a) 129 (b) 149
(c) 169 (d) 139

Answer: c

Explanation:

The given terms of the series are consists square of consecutive odd number $1^2, 3^2, 5^2, 7^2, \dots$. So missing value = $13^2 = 169$

Question 4

Find the next term of the series BKS, DJT, FIU, HHV,

- (a) JGW (b) JGV,
(C) JVG (d) BBA, ,

Answer: a

Explanation:

This type of question usually consists of a series of small letters which follow a certain pattern. However some letters are missing from the series. The missing letters are then given in proper sequence as one of the alternatives.

Question 5

3, 5, 11, 14, 17, 21 find the odd man out

- (a) 21 (b) 17
(c) 14 (d) 3

Answer: c

Explanation:

Each of the number except 14 is an odd number.
The number '14' is the only EVEN number.

Question 6

8, 27, 64, 100, 125, 216, 343 find the odd man out

- (a) 27 (b) 100
(c) 125 (d) 343

Answer: b

Explanation:

Except 100 all are cube of 2, 3, 4, 5, 6, and 7

Question 7

6, 9, 15, 21, 24, 28, 30

- (a) 28 (b) 21
(c) 24 (d) 30

Answer: a

Explanation:

Each of the numbers except 28 is a multiple of 3.

Question 8

582, 605, 588, 611, 634, 617, 600 Find out the wrong number in the given sequence of numbers.

- (a) 634 (b) 611
(c) 605 (d) 600

Answer: a

Explanation:

Alternatively, 23 is added and 17 is subtracted from the terms so, 634 is wrong

Question 9

1, 2, 6, 15, 31, 56, 91 Find out the wrong number in the given sequence of numbers.

- (a) 31 (b) 91
(c) 56 (d) 15

Answer: b

Explanation:

$1, 1 + 1^2 = 2, 2 + 2^2 = 6, 6 + 3^2 = 15, 15 + 4^2 = 31, 31 + 5^2 = 56, 56 + 6^2 = 92$

Last number of given series must be 92 not 91

Question 10

1, 8, 27, 64, 124, 216, 343 Find out the wrong number in the given sequence of numbers.

- (a) 8 (b) 27
(c) 64 (d) 124

Answer: d

Explanation:

The numbers are $1^3, 2^3, 3^3, 4^3$ etc. So, 124 is wrong; it must have been 5^3 i.e., 125

Question 11

8, 13, 21, 32, 47, 63, 83. Find out the wrong number in the given sequence of numbers.

- (a) 47 (b) 63
(c) 32 (d) 83

Answer: a

Explanation:

Go on adding 5, 8, 11, 14, 17, and 20.

So, the number 47 is wrong and must be replaced by 46

Question 12

Insert the missing number.

16, 33, 65, 131, 261, (....)

- (a) 523 (b) 521
(c) 613 (d) 721

Answer: a

Explanation:

Each number is twice the preceding one with 1 added or subtracted alternatively.

So, the next number is $(2 \times 261 + 1) = 523$

Question 13

Insert the missing number

2, 4, 12, 48, 240, (....)

- (a) 960 (b) 1440
(c) 1080 (d) 1920

Answer: b

Explanation:

Go on multiplying the given number by 2, 3, 4, 5, 6.
So, the correct next number is 1440

Question 14

Insert the missing number 8, 7, 11, 12, 14, 17, 17, 22, (...)

- (a) 27 (b) 20
(c) 22 (d) 24

Answer: b

Explanation:

There are two series (8, 11, 14, 17,) and (7, 12, 17, 22) increasing by 3 and 5 respectively.

Question 15

Find out the wrong number in the series.

7, 8, 18, 57, 228, 1165, 6996

- (a) 8 (b) 18
(c) 57 (d) 228

Answer: d

Explanation:

Let the given numbers of A, B, C, D, E, F, G.

Then $A, A \times 1 + 1, B \times 2 + 2, C \times 3 + 3 + D \times 4 + 4, E \times 5 + 5, F \times 6 + 6$ are the required numbers.
Clearly, 228 is wrong

Question 16

Find out the wrong number in the series 1, 2, 6, 24, 96, 720

- (a) 720 (b) 96
(c) 24 (d) 6

Answer: b

Explanation:

Go on multiplying with 1, 2, 3, 4, 5, 6 to get next numbers.
So, 96 is wrong

Question 17

Find out the wrong number in the series 196, 169, 144, 121, 100, 80, 64

- (a) 169 (b) 144
(c) 121 (d) 80

Answer: d

Explanation:

Number's must be $(14)^2, (13)^2, (12)^2, (11)^2, (10)^2, (9)^2, (8)^2$.
So, 80 is wrong

Question 18

Find out of the wrong number in series 445, 221, 109, 46, 25, 11, 4

- (a) 221 (b) 109
(c) 46 (d) 80

Answer: c

Explanation:

Go on subtracting 3 and dividing the result by 2 to obtain then next number.
Clearly, 46 is wrong

Question 19

Find out the wrong number in the series 190, 166, 145, 128, 112, 100, 91

- (a) 100 (b) 166
(c) 145 (d) 128

Answer: d

Explanation:

Go on subtracting 24, 21, 18, 15, 12, 9 from the next number.

$$190-24=166$$

$$166-21=145$$

$$145-18=127 \text{ [Here, 1288 is placed instead of 127]}$$

$$127-15=112$$

$$112-12=100 \text{ ... and so on}$$

Therefore, 128 is wrong

Question 20

In a certain code DELHI is written as CDKGH. How much is SUSPECT written in code?

- (a) RTRODBS. (b) QTRODBS
(c) RTIODBS (d) RTROIBS.

Answer: a

Explanation:

Clearly, we can see that each letter of the word DELHI is moved one step backward to obtain the code.

Similarly, SUSPECT will be coded as RTRODBS.

Question 21

In a certain code COURAGE is written as UOCREGA. How will JOURNAL be written in the code?

- (a) UOJRLAN (b) UOMRLAN
(c) UPJRLAN (d) ULOJRLAN

Answer: a

Explanation:

Clearly, when COURAGE is coded, some letters are interchange with respect to their positions, i.e. odd positions are interchanged.

Position of 1 changes to 3 and 3 to 1. Position of 5 changes to 7 and 7 to 5.

Can be coded as UOJRLAN

Question 22

Find out the wrong number in the series.

19, 26, 33, 46, 59, 74, 91

- (a) 26 (b) 33
(c) 46 (d) 59

Answer: b

Explanation:

Go on adding 7, 9, 11, 13, 15, 17 respectively to obtain the next number,

So, 33 is wrong it must be 35

Question 23**Find out the wrong number in the series 1, 3, 10, 21, 64, 129, 356, 777**

- (a) 10 (b) 21
(c) 64 (d) 356

Answer: d**Explanation:**

$A \times 2 + 1, B \times 3 + 1, C \times 2 + 1, D \times 3 + 1$ and so on.
So, 356 is wrong

Question 24**Find out the wrong number in the series 6, 12, 48, 100, 3884, 768, 3072**

- (a) 768 (b) 384
(c) 100 (d) 48

Answer: c**Explanation:**

Each even term of the series is obtained by multiplying the previous term by 2.
 $2^{\text{nd}} \text{ term} = (1^{\text{st}} \text{ term}) \times 2 = 6 \times 2 = 12$
 $4^{\text{th}} \text{ term} = (3^{\text{rd}} \text{ term}) \times 2 = 48 \times 2 = 96.$
 $6^{\text{th}} \text{ term} = (5^{\text{th}} \text{ term}) \times 2 = 384 \times 2 = 768.$
 $\therefore 4^{\text{th}} \text{ term should be } 96 \text{ instead of } 100$

Question 25**Insert the missing number. 7, 26, 63, 124, 215, 342, (...)**

- (a) 391 (b) 421
(c) 481 (d) 511

Answer: d**Explanation:**

Numbers are $(2^3 - 1), (3^3 - 1), (4^3 - 1), (5^3 - 1), (6^3 - 1), (7^3 - 1)$ etc.
So, the next number is $(8^3 - 1) = (512 - 1) = 511.$

Question 26**Find the odd man out? 396, 462, 572, 427, 671, 264**

- (a) 671 (b) 462
(c) 427 (d) 264

Answer: c**Explanation:**

Here the given series is 396, 462, 572, 427, 671, and 264.
In all the terms, the middle digit is the sum of first and third digit except 427.
So the odd number in the given series is 427.

Question 27**Insert the missing number. 2, 4, 12, 48, 240, (...)**

- (a) 960 (b) 1440
(c) 1080 (d) 1920

Answer: b**Explanation:**

Go on multiplying the given number by 2, 3, 4, 5, 6.
So, the correct next number is 1440.

Question 28**Find the odd man out 41, 43, 47, 53, 61, 71, 73, 81**

- (a) 41 (b) 61
(c) 71 (d) 81

Answer: d**Explanation:**

Each of the number except 81 is a prime number.

Question 29**Find out the wrong number in the given sequence of numbers 582, 605, 588, 611, 634, 617, 600**

- (a) 634 (b) 611
(c) 605 (d) 600

Answer: a**Explanation:**

Alternatively, 23 are added and 17 is subtracted from the terms. So, 634 is wrong.

Question 30**Find out the wrong number in the given sequence of numbers 1, 2, 6, 15, 31, 56, 91**

- (a) 31 (b) 91
(c) 101 (d) 15

Answer: b**Explanation:** $1, 1 + 1^2 = 2, 2 + 2^2 = 6, 6 + 3^2 = 15, 15 + 4^2 = 31, 31 + 5^2 = 56, 56 + 6^2 = 92$

Last number of given series must be 92 not 91

Question 31**Find odd number: 324, 244, 136, 352, 514**

- (a) 324 (b) 244
(c) 136 (d) 352

Answer: a**Explanation:**

Sum of the digits in each other number is 10.

 $324 = 9$ **Question 32****Find odd Number: 43, 53, 63, 73, 83**

- (a) 43 (b) 53
(c) 63 (d) 73

Answer: c**Explanation:**

Each of the numbers except 63 is a prime number.

Question 33**Find odd number: 10, 26, 24, 21, 18**

- (a) 10 (b) 26
(c) 24 (d) 21

Answer: d

Explanation:

Each of the numbers except 21 is an even number.

Question 34

Find odd number: 51, 144, 64, 121, 256

- (a) 51 (b) 144
(c) 64 (d) 121

Answer: a

Explanation:

Each of the number except 51 is a perfect square.

Question 35

Find odd number 15, 21, 24, 28, 30

- (a) 15 (b) 21
(c) 24 (d) 28

Answer: d

Explanation:

Each of the numbers except 28, is divisible by 3.

Question 36

Find odd number: 2384, 1592, 3756, 4298, and 3629

- (a) 2384 (b) 1592
(c) 3629 (d) 3756

Answer: c

Explanation:

In all other numbers, the last digit is two times the first, all are even but 3629 is ODD.

Question 37

Choose odd number: 7359, 1593, 9175, 3781, 9317

- (a) 7359 (b) 1593
(c) 3756 (d) 3781

Answer: d

Explanation:

All other numbers consist of odd digits only. Sum of all digits is prime in D.

Question 38

Find odd number: 8314, 2709, 1315, 2518, 3249

- (a) 8314 (b) 2709
(c) 1315 (d) 2518

Answer: a

Explanation:

In all number except 8314, the sum of first three digits is equal to the unit's digit. Hence, the answer is (a).

Question 39

Find odd number: 48, 12, 36, 24, and 59

- (a) 48 (b) 12
(c) 36 (d) 59

Answer: d

Explanation:

In all numbers except 59, the unit's digit is twice the ten's digit. Hence the answer is (d). And all are multiples of 12 too except 59

Question 40

Find odd number: 2345, 3456, 5467, and 5678

- (a) 2345 (b) 3456
(c) 5467 (d) 567

Answer: c

Explanation:

All other numbers contain four consecutive digits in order.

Question 41

Find the odd man out.

- (a) ZW (b) TQ
(c) SP (d) NL

Answer: d

Explanation:

Z⁻³W, T⁻²Q, S⁻³P, N⁻²L, P⁻³M

So the answer will be NL, which is choice (d).

Question 42

Find the odd among the following.

- (a) 1011 (b) 1101
(c) 1111 (d) 10001

Answer: c

Explanation:

These numbers follow the binary coding. Let's convert them into decimal.

$$\begin{aligned} 1011 &= 1 \times 2^3 + 0 \times 2^2 + 1 \times 2^1 + 1 \times 2^0 \\ &= 8 + 0 + 2 + 1 \\ &= 11 \end{aligned}$$

$$\begin{aligned} 1101 &= 1 \times 2^3 + 1 \times 2^2 + 0 \times 2^1 + 1 \times 2^0 \\ &= 8 + 4 + 0 + 1 \\ &= 13 \end{aligned}$$

$$\begin{aligned} 1111 &= 1 \times 2^3 + 1 \times 2^2 + 1 \times 2^1 + 1 \times 2^0 \\ &= 8 + 4 + 2 + 1 \\ &= 15 \end{aligned}$$

$$\begin{aligned} 10001 &= 1 \times 2^4 + 0 \times 2^3 + 0 \times 2^2 + 0 \times 2^1 + 1 \times 2^0 \\ &= 16 + 0 + 0 + 0 + 1 \\ &= 17 \end{aligned}$$

Here, choice (c) will be the answer because 15 is not a prime number but all others are prime numbers.

Question 43

Which of the following is wrong in the following series?

2, 7, 25, 77, 238, 723,

- (a) 7 (b) 238
(c) 77 (d) 25

Answer: d

Explanation:

-1, 3^2 , -2, 3^3 , -3, and $3^4 - 4$,....

The number in place of 25 should be $24 = 3^3 - 3$.

Hence (d) is the correct answer.

Question 44

**Choose the term which will continue the following series -
E3C, G5F, I8I, K12L,?**

(a) L170

(b) M19M

(c) N180

(d) M160

Answer: d

Explanation:

The first letters of the terms are alternate. The difference between the 1st and 2nd number is 2, 2nd and 3rd number is 3 and so on. Last letter of the 2nd number is 3 terms ahead of the last term of previous one. Thus the next term would be M160. Hence the answer is d.

Question 45

If EOGH is the code for BLADE, what is the code for CRICKET?

(a) FULFNHW

(b) ULFNHW

(c) HJLFNHW

(d) ULFHJ

Answer: a

Explanation:

FULFNHW

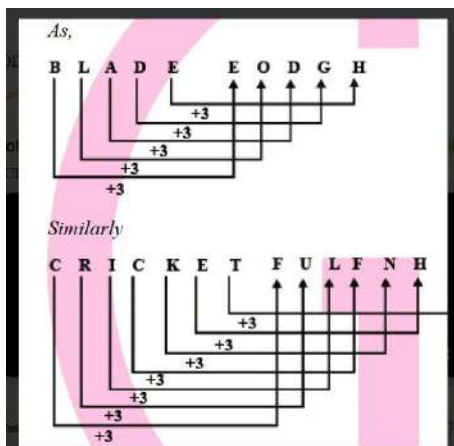

Question 46

If EARTH is coded as 41590 and PALE as 2134, what is the code for PEARL?

(a) P=2, E=4, A=0, R=5, and L=3

(b) P=2, E=4, A=1, R=5, and L=3

(c) P=2, E=4, A=1, R=5, and L=8

(d) P=8, E=, A=1, R=5 and L=3

Answer: b

Explanation:

24153 codes for letters are: P=2, E=4, A=1, R=5, and L=3

Question 47

In a certain language, 'put tir fin' means 'delicious juicy fruit'; 'tie dip sig' means 'beautiful white lily', and 'sig lon fin' means 'lily and fruit'. What is the code for 'and'?

- (a) lon (b) Oin
(c) Sag (d) None

Answer: a

Explanation:

'lon'

Common code from first and third statement for 'fin' is 'fruit'. From Second and third statement, 'sig' is 'lily'. So 'lon' means 'and' in third statement.

Question 48

The word RUN is coded as SVO. What should be the code letters of LAY?

- (a) MBZ (b) MBL
(c) BKL (d) MBA

Answer: a

Explanation:

∴ LAY should be MBZ.

PAST EXAMINATION QUESTIONS:

MAY 2018

Question 1

In a certain code, RIPPLE is written as 613382 and LIFE is written 8162. How is PILLER written in that code?

- (a) 318826 (b) 318286
(c) 618826 (d) 33881

Answer: a

Explanation:

PILLER is return that code is 318826

Question 2

In a certain code '256' means 'you are good', '637' means 'we are bad' and '358' means 'good and bad'. Which of the following represents 'and' in that code?

- (a) 2 (b) 5
(c) 8 (d) 3

Answer: c

Explanation:

256 means 'you are good'

637 means 'we are bad'

358 means 'Good and Bad'

Here code of 'are' is 3

Code of good is 5

Code of and is 8

Question 3

If LOSE is coded as 1357 and GAIN is code as 2468, what do figure 82146 for?

- (a) NGLAI (b) NGLIA
(c) GNLIA (d) GNLA

Answer: a

Explanation:

82146 is stands for NGLAI

NOV 2018

Question 1

If PLAY is coded as 8123 and RHYME is coded as 49367. What will be code of MALE?

- (a) 6217 (b) 6198
(c) 6395 (d) 6285

Answer: a

Play = 8123, RHYME = 49367 then
because M = 6, A = 2, I = 1, E = 7

Question 2

Find out the next number in the following series 7, 11, 13, 17, 19, 23, and 25)

- (a) 30 (b) 29
(c) 32 (d) 33

Answer: b

Explanation:

Given series

7, 11, 13, 17, 19, 23, 25, 29.

A prime number series, next prime number is 29

Question 3

If HONEY is coded as JQPGA, which word is code as VCTIGVV?

- (a) CARPETS (b) TRAPETS
(c) TARGETS (d) UMBRELU

Answer: c

Question 4

Find odd man out of the following series 15,, 21, 63, 81, 69.

- (a) 15 (b) 21

(c) 63

(d) 81

Answer: d**Explanation:**

15, 21, 63, 81, 69

Only 81 is a perfect square.

Question 5**Find odd man out of the following series 7, 9, 13, 17, 19**

(a) 7

(b) 9

(c) 19

(d) 13

Answer: b**Explanation:**

7, 9, 13, 17, 19

9 is the odd man out

Need to find odd number from given five numbers that are 7, 9, 13, 17, 19

A prime number is a whole number greater than 1 whose only factors are 1 and itself.

Let's do prime factorization of each number

Prime factorization of 7 is 7×1 Prime factorization of 13 is 13×1 Prime factorization of 17 is 17×1 Prime factorization of 19 is 19×1

But 9 is not a prime number. Since its factors are 3 and 1 and 9.

So the odd man out is 9.

MAY 2019**Question 1****If in a certain language, MADRAS is code as NBESBT, how is BOMBAY coded in that language?**

(a) CPNCBX

(b) CPNCBZ

(c) CPOCBZ

(d) CQOCBZ

Answer: b**Explanation:**

Clearly every letter is increased by 1 as

M+1 N

A+1 B

D+1 E

R+1 S

A+1 B

S+1 T

So after increasing every character in word BOMBAY by 1, we get

Question 2**Which of the following is odd one?**

- (a) CEHL (b) KMPT
(c) OQTX (d) NPSV

Answer: d**Explanation:**

- a. $\begin{matrix} C E H L \\ 3 5 8 1 2 \end{matrix}$ b. $\begin{matrix} K M P T \\ 1 1 1 3 1 6 2 0 \end{matrix}$ c. $\begin{matrix} N P S V \\ 1 4 1 6 1 9 2 3 \end{matrix}$

Last no. of all option is even except option d i.e., odd

Question 3**Which of the following is odd one 4, 12, 44, 176, 890.....?**

- (a) 4 (b) 12
(c) 44 (d) 176

Answer: c**Explanation:**

$$4 \div 4 = 1$$

$$12 \div 4 = 3$$

$$44 \div 4 = 11$$

$$176 \div 4 = 44$$

$$890 \div 4 = 222.4$$

Clearly, 890 is only number that is not completely by 4.

So, this is the odd one.

Question 4**Complete the series.****7, 23, 47, 119, 167**

- (a) 211 (b) 223
(c) 49 (d) 120

Answer: c**Explanation:**

Consider the provided series.

7, 23, 47, 119, 16, _____

In order to find the next term of the series observe the pattern as shown below:

$$7 = 9 - 2 = 3^2 - 2$$

$$23 = 25 - 2 = 5^2 - 2$$

$$47 = 49 - 2 = 7^2 - 2$$

$$119 = 121 - 2 = 11^2 - 2$$

$$167 = 169 - 2 = 13^2 - 2$$

Square the next prime number and subtract 2 from it.

$$17^2 - 2 = 289 - 2 = 287$$

Hence, the next number of the series is 287

NOV 2019

Question 1

Complete the series.

4, 16, 36, 64, 100

- (a) 144 (b) 121
(c) 49 (d) 120

Answer: A

Explanation:

(a) Given series

4, 16, 36, 64, 100,

$$2^2 = 4, 4^2 = 16, 6^2 = 36, 8^2 = 64, 10^2 = 100$$

The series is of squares of even no.'s so after 100 it will be

$$12^2 = 144$$

Question 2

Find the odd man out,

1, 5, 14, 30, 51, 55, 91

- (a) 5 (b) 55
(c) 51 (d) 91

Answer: c

Explanation:

As the series is having the sum of all squares of natural number therefore 51 is the odd number.

Question 3

Find the odd man out 5, 10, 17, 27, 37;

- (a) 5 (b) 17
(c) 27 (d) 10

Answer: c

Explanation:

(c) $(2 \times 2) + 1 = 5$

$$(3 \times 3) + 1 = 10$$

$$(4 \times 4) + 1 = 17$$

$$\text{But } (5 \times 5) + 1 = 26$$

$$(6 \times 6) + 1 = 37$$

So 27 is odd man out.

Question 4

Complete the series

4, 16 _____ 256, 1024

- (a) 32 (b) 48
(c) 64 (d) 46

Answer: c

Explanation:

$$(c) 4^1 = 4$$

$$4^2 = 4 \times 4 = 16$$

$$4^3 = 4 \times 4 \times 4 = 64$$

$$4^4 = 4 \times 4 \times 4 \times 4 = 256$$

$$4^5 = 4 \times 4 \times 4 \times 4 \times 4 = 1024$$

So the third form of the series is 64.

Question 5

SYSTEM is coded as 131625 then TERMS will be coded as?

- (a) 62251 (b) 62451
(c) 64251 (d) 62415

Answer: (b)

Since in

SYSTEM
131625

(Given)

TERMS
62451

∴ As R cannot be 2 as E has already been assigned the value as 2
R's value left will be 4 as per given option.

DEC 2020

Question 1

Find the missing value in the series 0, 2, 3, 6, 10, 17, 28, ? 75.

- (a) 58 (b) 46
(c) 48 (d) 54

Answer: b

Explanation;

$$2+3 +1=6$$

$$3+6 +1=10$$

$$6+10 +1=17$$

You go on like this and the next number will be $17 + 28 + 1 = 46$

Question 2

$$\frac{3}{8}, \frac{8}{19}, \frac{18}{41}, ?, \frac{78}{173}$$

(a) $\frac{38}{85}$

(b) $\frac{83}{38}$

(c) $\frac{81}{38}$

(d) None

Answer: a**Explanation:**

$3+5 = 8$

$8+10 = 18$

$18 + 20 = 38$

$38 + 40 = 78$

$= 38/85$

Question 3**Find Odd man out of the following 6, 9, 12, 18, 21, 26, and 30**

(a) 24

(b) 30

(c) 26

(d) 9

Answer: c**Explanation:**

Each of the numbers except 26, is a multiple of 3.

Question 4**If in a certain language HEALTH is coded as IFBMUI then what is the code for NORTH**

(a) OPSUI

(b) OPUSI

(c) OUSPI

(d) OIPSU

Answer: a**Explanation:**

Given

HEALTH is coded as IFBMUI

To find code for North

In HEALTH each letter is coded as:

Each letter of HEALTH is moved one step forward and coded as IFBMUI

Similarly for NORTH we have to move one step forward in each letter so North will be coded as OPSUI.

Question 5**Find the Wrong Term in:****G4T, J10R, M20P, P43N, S90L**

(a) M20P

(b) P43N

(c) J10R

(d) G4T

Answer: c**Explanation:**

The first letter of each term is moved three steps forward and the last letter is moved two steps backward to obtain the corresponding letters of the next term.

The numbers follow the sequence $\times 2+1, \times 2+2, \times 2+3, \times 2+4$.

So, 10 is wrong and must be replaced by $(4 \times 2+1)$ i.e. 9.

IAN 2021

Question 1

$$\frac{1}{2}, \frac{3}{4}, \frac{5}{8}, \frac{7}{16} = ?$$

(a) $\frac{9}{32}$

(b) $\frac{10}{17}$

(c) $\frac{11}{34}$

(d) $\frac{12}{35}$

Answer: a

Explanation:

$9/32$ because the numerators are the consecutive odd numbers and the denominators are consecutively being multiplied by 2.

Question 2

Find the missing term:

P3C, R5F, T8I, V12L,?

(a) Y170

(b) X17M

(c) X170

(d) X 160

Answer: c

Explanation:

Option C is the correct answer

In the following series first letter is moved two steps forward, second number is moved 2,3,4,5 step forward, and third letter is moved and third letter is moved three steps forward to form the next term of the series

Following the series the next term will be X170

Question 3

Find out the odd man in the sequence 8, 27, 64, 125, 196, 216.

(a) 27

(b) 196

(c) 125

(d) 216

Answer: b

Explanation:

The given numbers are : 8, 27, 64, 125, 196, 216, .

Among these , 196 is the odd one out .

It is because all the other numbers are perfect cubes whereas 196 is a perfect square

Question 4

In a certain code language, BEAT is written as YVZG, and then what will be the code for MILD?

- (a) ONRW (b) NOWR
(c) ONWR (d) NROW

Answer: d

Explanation:

Given, BEAT is written as YVZG.

We know that B, E, A, T are respectively the 2nd, 5th, 1st and 20th letters from the beginning of the English alphabet. The letters of the code Y, V, Z, G are respectively the 2nd, 5th, 1st and 20th letters from the end of the English alphabet. Similarly, M, I, L, D are respectively the 13th, 9th, 12th and 4th letters from the beginning of the English alphabet. Now, the 13th, 9th, 12th and 4th letters from the end of the English alphabet are N, R, O, W respectively. So, MILD is coded as NROW.

Hence, option (D) is the correct answer.

Question 5

In a certain code RIPPLE is written as 613382, and LIFE is written as 8192. How will PILLER be written in that code?

- (a) 618892 (b) 689912
(c) 318826 (d) 629981

Answer: c

Explanation:

The alphabets are coded as shown :

R	I	P	L	E	F
6	1	3	8	2	9

So, in PILLER, P is coded as 3,

I as 1,

L as 8,

E as 2 and

R as 6.

Thus, the code for PILLER is 318826.

JULY 2021

Question 1

Chose the missing term in the series..... 1,1, 8, 4, 27,___64,16

- (a) 27 (b) 11
(c) 9 (d) 125

Answer: Options (c)

Explanation:

Correct option is c = 9

The series consists of squares and cubes of squares and cubes of consecutive natural numbers i.e.

$$1^2, 1^3, 2^3, 2^2, 3^3, 4^3, 4^2, \dots$$

So missing term = $3^2 = 9$

Question 2

The wrong term in the series 225, 196, 169, 121, 100, 77, 64, is ____

- | | |
|---------|---------|
| (a) 121 | (b) 77 |
| (c) 100 | (d) 169 |

Answer: Options (b)

Explanation:

Correct option is b = 77

By taking a close look at all the numbers in the sequence it is clear that all the given numbers are perfect squares of numbers.

$$15 \times 15 = 225$$

$$14 \times 14 = 196$$

$$13 \times 13 = 169$$

$$11 \times 11 = 121$$

$$10 \times 10 = 100$$

$$9 \times 9 = 81 \text{ but the number given in the series is } 77$$

So 77 is the wrong term from the series.

Option b is the correct Answer

Question 3

If Delhi is coded as EFMIJ then Jaipur is coded as_

- | | |
|------------|------------|
| (a) JQVSBK | (b) QVSKBJ |
| (c) BJQVSK | (d) KBJQVS |

Answer: Options (d)

Question 4

If frame is coded as 0618011305 then Arise is coded as_

- | | |
|----------------|----------------|
| (a) 0118091905 | (b) 0119091805 |
| (c) 0118190905 | (d) 0118091805 |

Answer: Options (a)

Question 5

If Clock is coded as 34235 and Time as 8679, then Motel is coded as

- | | |
|-----------|-----------|
| (a) 27894 | (b) 72964 |
| (c) 72894 | (d) 77684 |

Answer: Options (c)

DEC 2021**Question 1**

If MOUSE, is coded as 34651 and KEY is coded as 217, then how will YES be coded?

- (a) 715 (b) 517
(c) 175 (d) 571

Answer: a

Explanation:

M	O	U	S	E	K	E	Y	Y	E	S
3	4	6	5	1	2	1	7	7	1	5

Question 2

What comes at the last place in R, U, X, A, D

- (a) E (b) F
(c) G (d) H

Answer: c

Explanation:

We have $R + 3 = U$

$U + 3 = X$

$X + 3 = A$

$A + 3 = D$

$D + 3 = G$

Question 3

The missing term of the series 4, 13,49, 76 is

- (a) 26 (b) 30
(c) 28 (d) 32

Answer: b

Question 4

Find the odd one from the following

- (a) Zebra (b) Horse
(c) Giraffe (d) Tiger

Answer:

Explanation:

Here, Zebra, Giraffe, Horse are herbivorous animal Except 'Tiger'.

Question 5

In certain code, MENTION is written as LNEITNO. How is PRESENT written in that code?

- (a) NTSEREO (b) OERESTN

(c) ERESTNO

(d) ROESTNE

Answer: b**Explanation:**

In the certain code. It is proved that the correct answer is b

Question 6**If in a certain code “THANKS” is written as “SKNTHA” then how us “STUPID” written?**

(a) DIPUTS

(b) DISPUT

(c) DIPUST

(d) DIPSTU

Answer: d**Explanation:**

The code of THANKS is made as follows

The last three letters are reversed, and then the first three letters are written as it is.

Similarly, the code of STUPID would be DIPSTU.

JUNE 2022**Question 1****7, 26, 63, 124, 215, 342 _____?**

(a) 511

(b) 672

(c) 508

(d) 556

Answer: Options (a)**Explanation:**

7, 26, 63, 124, 215, 342

Here, $2^3 - 1 = 7$, $6^3 = 216 - 1 = 215$ $3^3 - 1 = 26$, $7^3 = 343 - 1 = 342$ $4^3 - 1 = 63$, $8^3 = 512 - 1 = 511$ $5^3 - 1 = 124$ **Question 2****LOUTS is coded as 14682 and STRANGE is codes as 2690753. How will you code GESTURE**

(a) 5236893

(b) 5326793

(c) 5346893

(d) 5326893

Answer: Options (d)**Explanation:**

L O U T S

S T R A N G E

G E S T U R E

↓ ↓ ↓ ↓ ↓

↓ ↓ ↓ ↓ ↓ ↓ ↓

↓ ↓ ↓ ↓ ↓ ↓ ↓

1 4 6 8 2

2 6 9 0 7 5 3

5 3 2 6 8 9 3

Question 3

4, 6, 9, 13, 5 _____, 30.375

- (a) 40.50 (b) 20.25
(c) 40.75 (d) 60.25

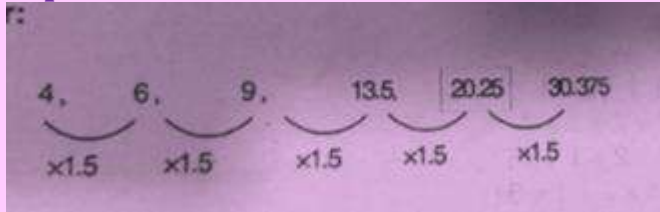
Answer: Options (b)**Explanation:****Question 4**

Code for Word EARTH is 16235 and VENUS 91784 what is code for SATRUN?

- (a) 423827 (b) 463827
(c) 463877 (d) 413827

Answer: Options (b)**Explanation:**

E	A	R	T	H		V	E	N	U	S		S	A	T	U	R	N
↓	↓	↓	↓	↓		↓	↓	↓	↓	↓		↓	↓	↓	↓	↓	↓
1	6	2	3	5		9	1	7	8	4		4	6	3	8	2	7

Question 5

Find out the next term -

7, 11, 27, 63, 127, ___

- (a) 511 (b) 227
(c) 5100 (d) 255

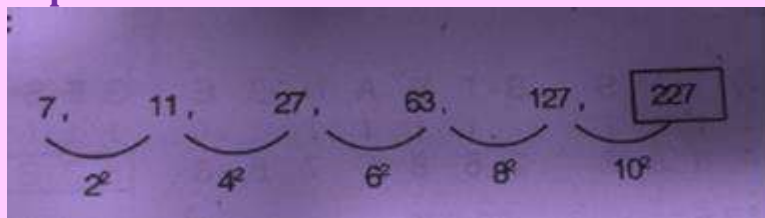
Answer: Options (b)**Explanation:****Question 6**

Find the next terms -

3, , 15, 31, ?, 127

- (a) 62 (b) 63
(c) 64 (d) 65

Answer: Options (b)

Explanation:

3, 7, 15, 31, 63, 127

$$3 \times 2 + 1 = 7$$

$$7 \times 2 + 1 = 15$$

$$15 \times 2 + 1 = 31$$

$$31 \times 2 + 1 = 63$$

$$63 \times 2 + 1 = 127$$

Question 7

Find out the next term-

6, 13, 28, 59, ?

(a) 122

(b) 114

(c) 113

(d) 112

Answer: Options (b)

Explanation:

6, 13, 28, 59, 122

$$6 \times 2 + 1 = 13$$

$$13 \times 2 + 2 = 28$$

$$28 \times 2 + 3 = 59$$

$$59 \times 2 + 4 = 122$$

DEC 2022

Question 1

If ROSE is coded as 6821, CHAIR is coded as 73456 and PREACH is coded as 961473, what will be the code for SEARCH?

a) 246173

b) 214673

c) 216473

d) 214763

Answer: Options (b)

Explanation:

As per the codes given

ROSE=682

CHAIR=73456

PREACH=961473

Code for SEARCH will be=214673

answer is Option (b)

Question 2

In certain code language, if TOUR is written as 1234, CLEAR is written 5678 and SPARE is written as 90847, find the code for CARE?

a) 1247

b) 4847

c) 5247

d) 5847

Answer: Options (d)**Explanation:**

The code for TOUR is:

T	O	U	R
1	2	3	4

The code for CLEAR is:

C	L	E	A	R
5	6	7	8	4

The code for SPARE is:

S	P	A	R	E
9	0	8	4	7

Similarly,

The code for CARE is:

C	A	R	E
5	8	4	7

Hence, '5847' is the correct answer.

Question 3

How many 3 digit odd numbers can be formed using the digits 5, 6, 7, 8, 9, if the digits can be repeated?

- | | |
|-------|-------|
| a) 55 | b) 75 |
| c) 65 | d) 85 |

Answer: Options (b)**Explanation:**

Let us take the 3 digit number as H T U (Hundreds, tens, unit digit) respectively

To make 3 digit number as odd

5, 7, 9 are only possibly be used in the unit digit place

In hundreds and tens place all 5 digits are possible

Number of ways for unit digit = 3
 Number of ways for tens digit = 5
 Number of ways for hundreds digit = 5

Number of 3 digits odd number = $3 \times 5 \times 5 = 75$

\therefore 75 Three-digit odd numbers can be formed from the digits 5, 6, 7, 8, 9 if the digits can be repeated

Question 4

Find the odd man out:

34, 105, 424, 2123, 12756

- | | |
|----------|---------|
| a) 12756 | b) 2123 |
| c) 424 | d) 34 |

Answer: Options (b)

Explanation:

3rd term = (2nd term) \times 2 + 2 = $16 \times 2 + 2 = 34$.

4th term = (3th term) \times 3 + 3 = $34 \times 3 + 3 = 105$.

5th term = (4th term) \times 4 + 4 = $105 \times 4 + 4 = 424$

6th term = (5th term) \times 5 + 5 = $424 \times 5 + 5 = 2125$

\therefore 6th term should 2125 instead of 2123.

Question 5

If 'FORZEN' is decoded as 'OFAPSG'. Tick the right option that depicts "MOLTEN" written in this way?

- | | |
|-----------|-----------|
| a) OFPOMN | b) OFSMPN |
| c) OFUMPN | d) OFUNPN |

Answer: Options (c)

Explanation:

Reverse the word and move each letter +1 . Reverse of MOLTEN is NETLOM add 1 to each letter of NETLOM. So code of MOLTEN become OFUMPN.

CHAPTER - 10 DIRECTION SENSE TEST

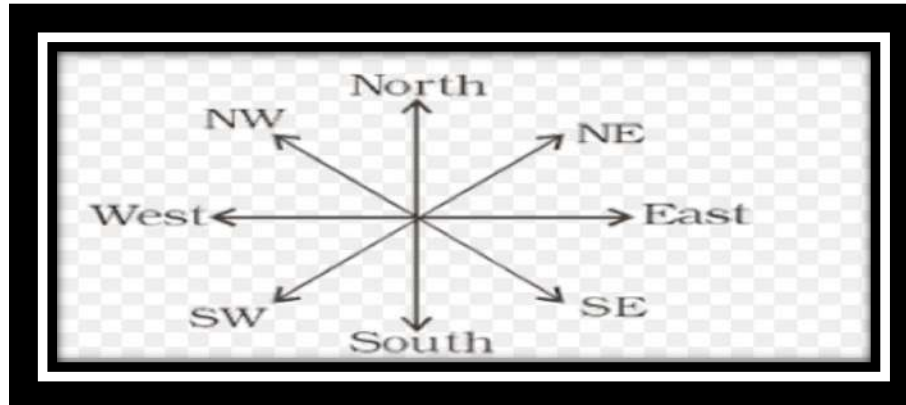

ALWAYS REMEMBER:

LEFT & LEFT	Down
RIGHT & LEFT	UP
LEFT & RIGHT	UP
RIGHT & RIGHT	Down
UP & LEFT	Left
UP & RIGHT	Right
DOWN & LEFT	Right
DOWN & RIGHT	Left



Question1

One morning Udai and Vishal were talking to each other face to face at a crossing. If Vishal's shadow was exactly to the left of Udai, which direction was Udai facing?

- (a) East. (b) West
(c) North (d) South

Answer: C

Explanation:

**Question2**

Y is in the East of X which is in the North of Z. If P is in the South of Z, then in which direction of Y, is P?

- (a) North (b) South
(c) South-East (d) None of these

Answer: D

Explanation:

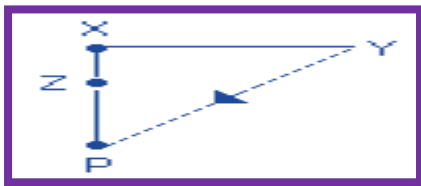

P is in South-West of Y

Question 3

If South-East becomes North, North-East becomes West and so on. What will West become?

- (a) North-East (b) North-West
(c) South-East (d) South-West

Answer: C

Explanation:

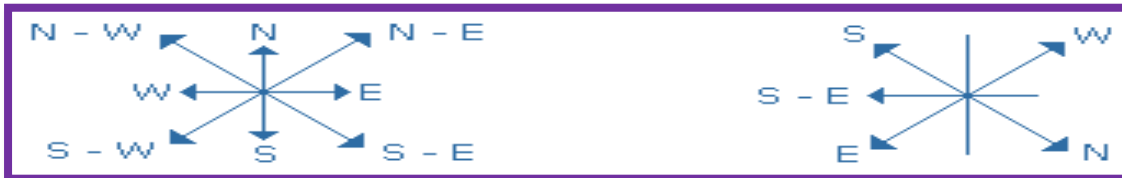

It is clear from the diagrams that new name of West will become South-East

Question4

A man walks 5 km toward south and then turns to the right. After walking 3 km he turns to the left and walks 5 km. Now in which direction is he from the starting place?

- (a) North-East (b) North-West
(c) South-East (d) South-West.

Answer: D

Explanation

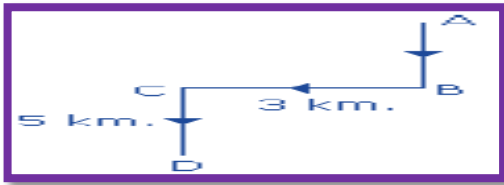

Hence required direction is South-West.

Question 5

Rahul put his timepiece on the table in such a way that at 6 P.M. hour hand points to North. In which direction the minute hand will point at 9.15 P.M.?

- (a) South-East
- (b) South
- (c) North
- (d) West

Answer: D

Explanation:

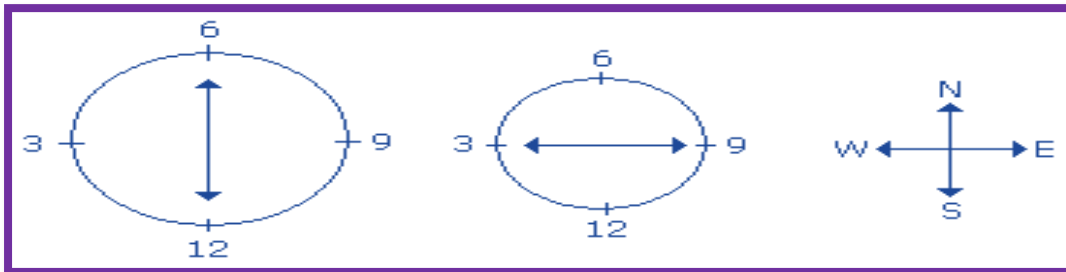

At 9.15 P.M., the minute hand will point towards west

Question 6

Two cars start from the opposite places of a main road, 150 km apart. First car runs for 25 km and takes a right turn and then runs 15 km. It then turns left and then runs for another 25 km and then takes the direction back to reach the main road. In the meantime, due to minor break down the other car has run only 35 km along the main road. What would be the distance between two cars at this point?

- (a) 65 km
- (b) 75 km
- (c) 80 km
- (d) 85 km

Answer: A

Explanation:

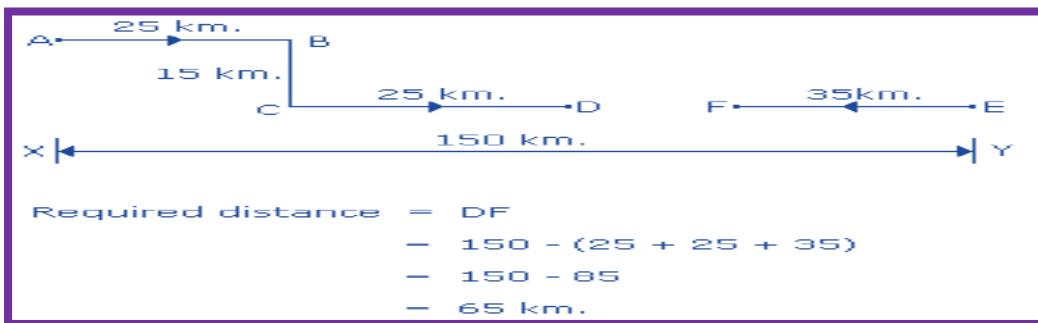

Question 7

Starting from the point X, Jayant walked 15 m towards west. He turned left and walked 20 m. He then turned left and walked 15 m. After this he turned to his right and walked 12 m. How far and in which directions is now Jayant from X?

(a) 32 m, South

(b) 47 m, East

(c) 42 m, North

(d) 27 m, South

Answer: A

Explanation:

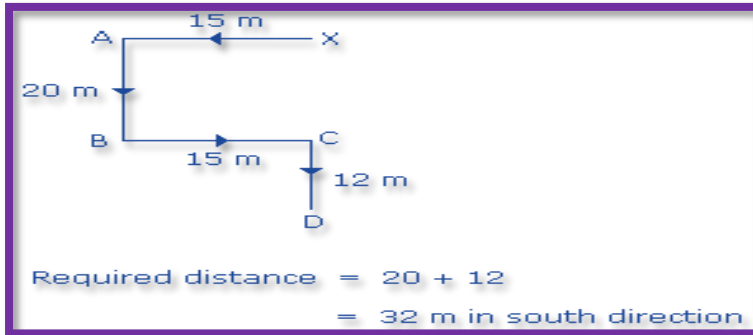

Question 8

One evening before sunset Rekha and Hema were talking to each other face to face. If Hema's shadow was exactly to the right of Hema, which direction was Rekha facing?

(a) North

(b) South

(c) East

(d) Data is inadequate

Answer: B

Explanation:



In the evening sun sets in West. Hence then any shadow falls in the East. Since Hema's shadow was to the right of Hema. Hence Rekha was facing towards South.

Question 9

A boy rode his bicycle Northward, then turned left and rode 1 km and again turned left and rode 2 km. He found himself 1 km west of his starting point. How far did he ride northward initially?

(a) 1 km

(b) 2 km.

(c) 3 km

(d) 5 km

Answer: B

Explanation:

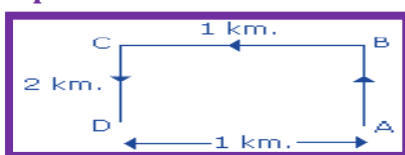

The boy rode 2 km. Northward.

Question10

K is 40 m South-West of L. If M is 40 m South-East of L, then M is in which direction of K?

- (a) East (b) West
(c) North-East (d) South

Answer: A

Explanation:

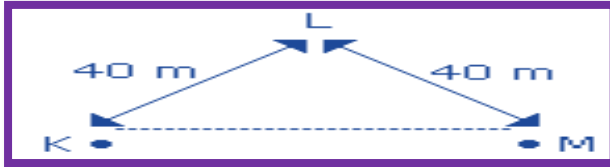

Hence M is in the East of K.

Question11

A man walks 2 km towards North. Then he turns to East and walks 10 km. After this he turns to North and walks 3 km. Again he turns towards East and walks 2 km. How far is he from the starting point?

- (a) 10 km (b) 13 km
(c) 15 km (d) None of these

Answer: B

Explanation:

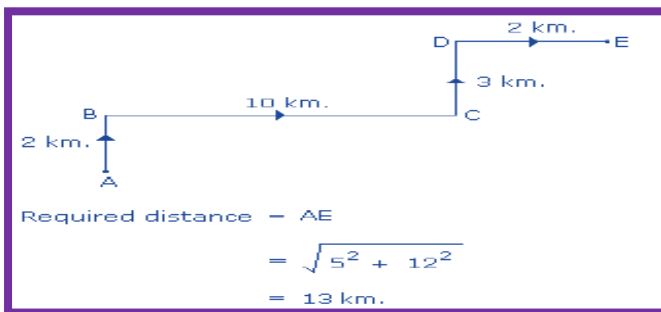
**Question 12**

The length and breadth of a room are 8 m and 6 m respectively. A cat runs along all the four walls and finally along a diagonal order to catch a rat. How much total distance is covered by the cat?

- (a) 10 (b) 14
(c) 38 (d) 48

Answer: C

Explanation:

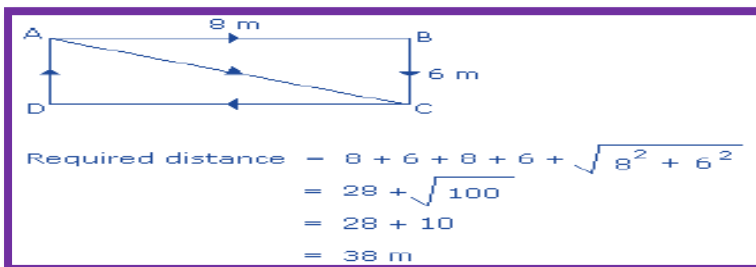

Question13

One morning sujata started to walk towards the Sun. After covering some distance, she turned to right then again to the right and after covering some distance she again turns to the right. Now in which direction is she facing?

- (a) North (b) South
(c) North-East (d) South-West

Answer: A

Explanation:

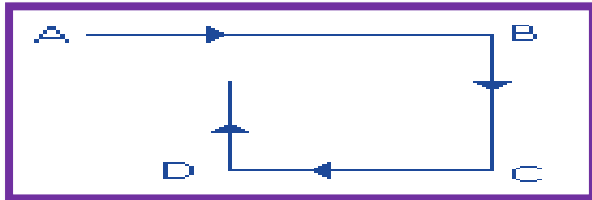

Hence finally Sujata will face towards North.

Question14

Some boys are sitting in three rows all facing north such that A is in the middle row. P is just to the right of A but in the same row. Q is just behind of P while R is in the North of A. In which direction of R is Q?

- (a) North (b) South- East
(c) North-East (d) South-West

Answer: b

Explanation:

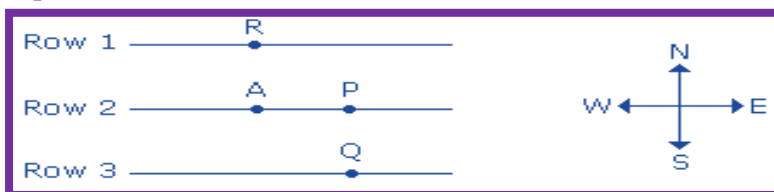

Q is in South-East of R

Question15

One morning after sunrise, Vimal started to walk. During this walking he met Stephen who was coming from opposite direction. Vimal watch that the shadow of Stephen to the right of him (Vimal). To which direction Vimal was facing?

- (a) East (b) West
(c) South (d) Data inadequate

Answer: C

Explanation:

Sun rises in the east. So the shadow of a man will always falls towards the west. Since the shadow of Stephen is to the right of Vimal. Hence Vimal is facing towards South.

Question 16

Golu started from his house towards North. After covering a distance of 8 km. he turned towards left and covered a distance of 6 km. What is the shortest distance now from his house?

- (a) 10 km (b) 14 km
(c) 14 km (d) 2 km

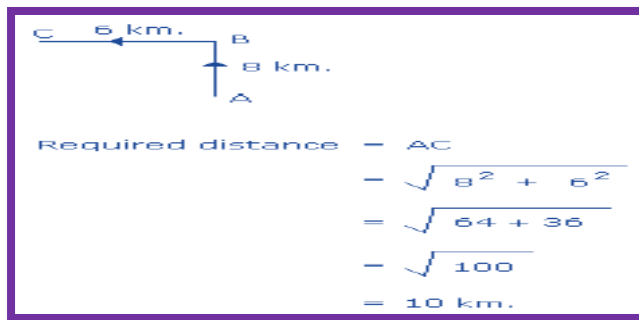
Answer: A**Explanation:****Question 17**

P started from his house towards west. After walking a distance of 25 m. He turned to the right and walked 10 m. He then again turned to the right and walked 15 m. After this he is to turn right at 135° and to cover 30 m. In which direction should he go?

- (a) West (b) South
(c) South-West (d) South-East

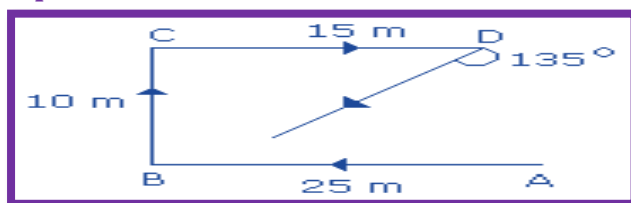
Answer: C**Explanation:**

Hence he should go in the South-West direction.

Question 18

X-Men started to walk straight towards south. After walking 5 m he turned to the left and walked 3 m. After this he turned to the right and walked 5 m. Now to which direction X is facing?

- (a) North-East (b) South
(c) North (d) South-West

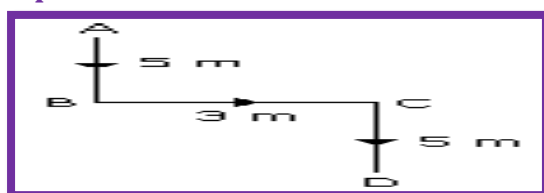
Answer: B**Explanation:**

Hence X-Men will face in the end towards South.

Question 19

Hemant in order to go to university started from his house in the east and came to a crossing. The road to the left ends in a theatre, straight ahead is the hospital. In which direction is the university?

- (a) North
- (b) South
- (c) East
- (d) West

Answer: A

Explanation:

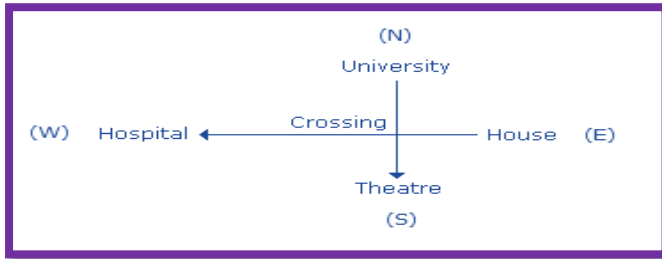

Therefore, university is in North

Question 20

If a boy starting from Niles, met to Ankur and then to Kumar and after this he to Dev and then to Pintu and whole the time he walked in a straight line, then how much total distance did he cover?

- (a) 215 m
- (b) 155 m
- (c) 245 m
- (d) 185 m

Answer:A

Explanation:

Required distance = 25 m + 40 m + 60 m + 90 m

Required distance = 215 m

Question 21

Each of the following questions is based on the following information:

Six flats on a floor in two rows facing North and South are allotted to P, Q, R, S, T and U.

Q gets a North facing flat and is not next to S.

S and U get diagonally opposite flats.

R next to U, gets a south facing flat and T gets North facing flat.

If the flats of P and T are interchanged, then who's flat will be next to that of U?

- (a) P
- (b) Q
- (c) R
- (d) T

Answer: C

Explanation:

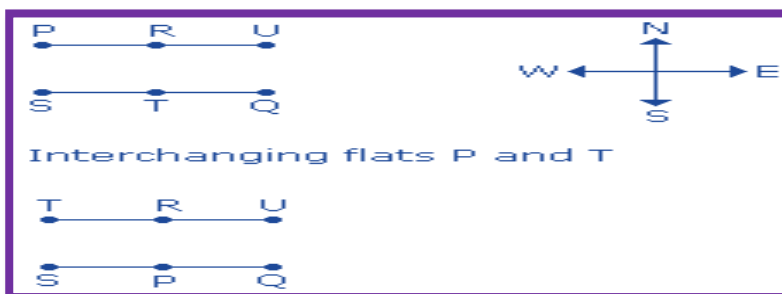

Hence flat R will be next to U.

Question22

Which of the following combination get south facing flats?

(a) QTS

(b) UPT

(c) URP

(d) Data is inadequate

Answer: C**Explanation:**

Hence URP flat combination get south facing flats.

Question 23

Rasik walked 20 m towards north. Then he turned right and walks 30 m. Then he turns right and walks 35 m. Then he turns left and walks 15 m. Finally, he turns left and walks 15 m. In which direction and how many meters is he from the Starting position?

(a) 15 m West

(b) 30 m East

(c) 30 m West

(d) 45 m East

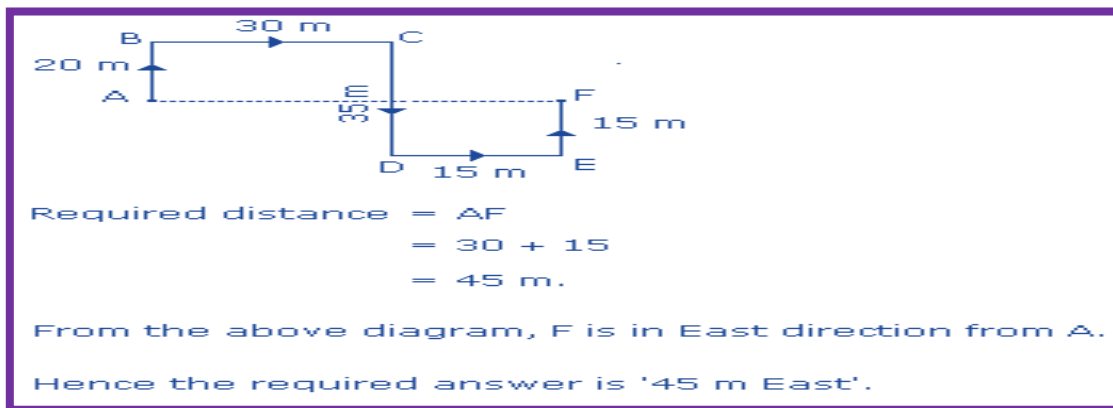
Answer: D**Explanation:****Question 24**

Eight persons M through T are standing in such a way that O is 20 m apart from N towards West, N is 30 m South with respect to M. M is 40 m towards West with respect to Q. P is 50 m towards South with respect to Q. R is 15 m apart from S towards North. T is 20 m towards East with respect to S. R is 40 m towards West with respect to P. In which direction is Q standing with respect to R?

(a) North-West

(b) North

(c) North-East

(d) Cannot be determined

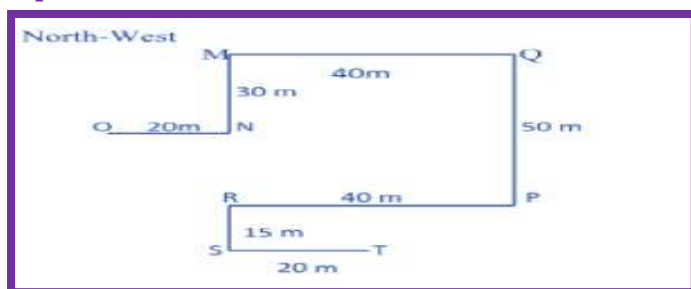
Answer: C**Explanation:****Question 25**

Two buses start from the opposite points of a main road, 150km apart. The first bus runs for 25 km and takes a right turn and then runs for 15km. It then turns left and runs for another 25km and takes the direction back to reach the main road. In the meantime, due to the minor break down the other bus has run only 35km along the main road. What would be the distance between the two buses at this point?

- (a) 65km (b) 80km
(c) 75km (d) 85km

Answer: A

Explanation:

Required distance = $PQ = 150 - (25 + 25 + 35) = 65\text{km}$

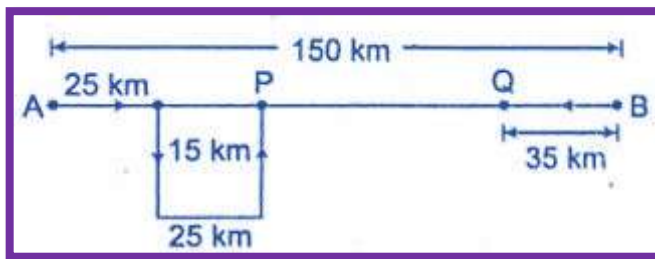

Question 26

Mohan walked 30m towards South, took a left turn and walked 15m. He, then took a right turn and walked 20m. He again took a right turn and walked 15m. How far is he from the starting point?

- (a) 95m (b) 50m
(c) 70m (d) Cannot be determined

Answer: B

Explanation:

Required distance = $OD = OA + AD = OA + BC = 30 + 20 = 50\text{m}$

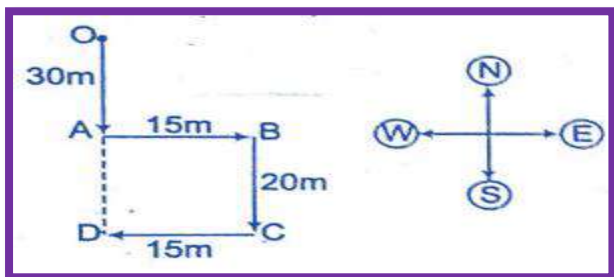

Question 27

Starting from the point X, Jayant walked 15 m towards west. He turned left and walked 20 m. He then turned left and walked 15 m. After this he turned to his right a walked 12 m. How far and in which directions is now Jayant from X?

- (a) 32 m, South (b) 47 m, East
(c) 42 m, North (d) 27 m, South

Answer: A

Explanation:

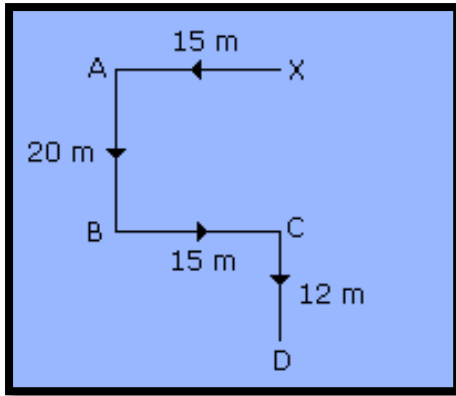
**Question28**

Lakshman went 15 kms to the West of his house, then turned left and walked 20 kms. He then turned East and walked 25 kms and finally turning left covered 20 kms. How far was he from his house?

(a) 15 kms

(b) 20 kms

(c) 25kms

(d) 10 kms

Answer: b

Explanation:

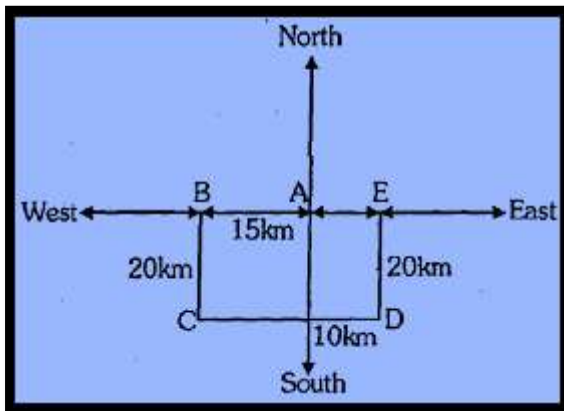
**Question 29**

A starts from a point and walks 5kms north, then turns left and walks 3kms. Then again turns left and walks 5kms. Point out the direction in which he is going.

(a) West

(b) South

(c) North

(d) East

Answer: D

Explanation:

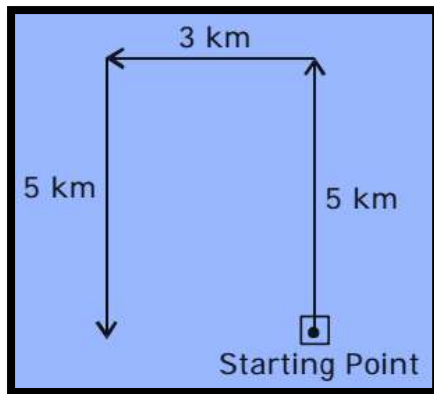
**Question 30**

A person walks 4 km towards west, then turns to his right to travel 9 km. He turns towards east and travels 12 km. Finally, he travels 3 km towards south. How far is he from the initial position (in km)?

- (a) 15
(c) 18

- (b) 23
(d) 10

Answer: d

Explanation:

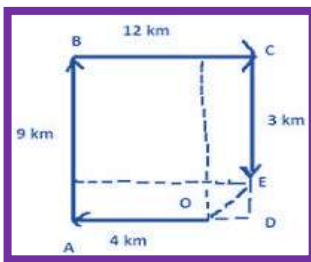

From the figure, the distance OE is to be calculated. In triangle ODE, $OE = \sqrt{(OD^2) + (DE^2)}$
 $= \sqrt{(BC - AO)^2 + (AB - CE)^2}$ $OE = \sqrt{(8^2 + 6^2)} = 10\text{km.}$

Question31

One evening before sunset two friends Sumit and Mohit were talking to each other face to face. If Mohit's shadow was exactly to his right side, which direction was Sumit facing?

- (a) North
(c) West

- (b) south
(d) Data in adequate

Answer: B

Explanation:

In the evening, sun is in the west and so the shadows fall towards east. Now, since Mohit's shadow fell towards right, therefore, Mohit is facing North. So, Sumit standing face to face with Mohit, was facing South.

Question 32

A girl leaves from her home. She first walks 30 meters in North-west direction and then 30 meters in South-west direction. Next, she walks 30 meters in South-east direction. Finally, she turns towards her house. In which direction is she moving?

- (a) North-East
- (c) South-East

- (b) North-West
- (d) South-East

Answer: a

Explanation:

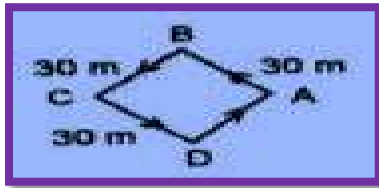

The movements of the girl are as shown in Fig. (A to B, B to C, C to D, D to A). Clearly, she is finally moving in the direction DA i.e. north east.

Question33

A man goes towards East 5km, then he takes a turn to South-West and goes 5km. He again takes a turn towards North-West and goes 5km with respect to the point from where he started, where is he now?

- (a) At the starting point
- (b) In the West
- (c) In the East
- (d) In the North East

Answer: a

Explanation:

According to the question, the direction diagram is as follows

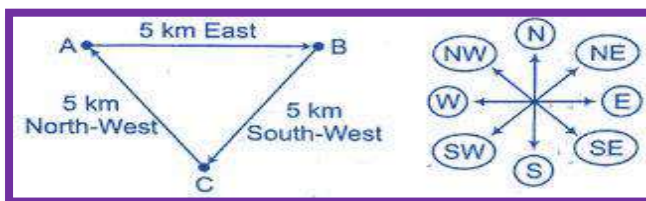

It is clear from the diagram that both starting and finishing point are same i.e. , the man is at starting point 'A'.

Question 34

Nikhil walked 30m towards East took a left turn and walked 20m. He again took a left turn and walked 30m. How far and in which direction is he from his starting point?

- (a) 20m, North
- (b) 80m, North
- (c) 20m, South
- (d) 80m, South

Answer: a

Explanation:

According to the question, the direction diagram is as follows

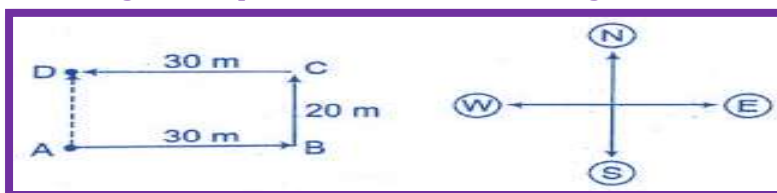

Required distance = AD = BC = 20m
So, Nikhil is 20m North from his starting point

Question35

Rakesh is standing at a point. He walks 20m towards the East and further 10m towards the South, then he walks 35m towards the West and further 5 m towards the North, then he walks 15 m towards the East. What is the straight distance (in m) between his starting point and the point where he reached last?

- (a) 0 (b) 5
(c) 10 (d) Cannot be determined

Answer: b

Explanation:

According to the question. The direction diagram is as follows



From diagram, $AB = 20\text{m}$ $BC = HD = 10\text{m}$
 $ED = 5\text{m}$ $CD = 35\text{m}$ $HE = AF$
 Required distance, $AF = HF = HD - ED$
 $= 10 - 5 = 5\text{m}$

Question 36

Anoop starts walking towards South. After walking 15m he turns towards North. After walking 20m, he turns towards East and walks 10m. He, then turns towards South and walks 5m. How far is he from his original position in which direction?

- (a) 10m, North (b) 10m, South
(c) 10m, West (d) 10m, East

Answer: d

Explanation:

According to the question, the direction diagram is as follows

A = Original position, E = Finishing point

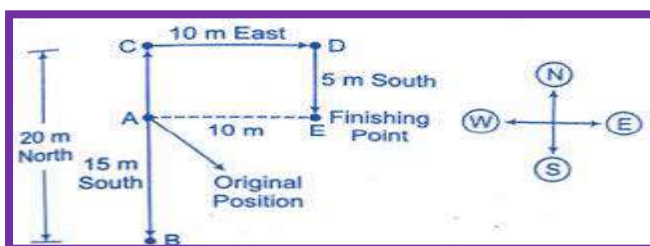

$BC = 20$, $AB = 15$, $AC = ED = 5\text{m}$, $CD = AE = 10\text{m}$
 Clearly, at finishing point E, Anoop is 10 m East from original position A.

Question 37

From a point, Rajneesh started walking East and walked 35m. He, then turned on his right and walked 35m. He, then turned on his right and walked 20m and he again turned to right and walked 35m. Finally, he turned his left and walked 20m and reached his destination. Now, how far is he from the starting point?

- (a) 50m (b) 55m
(c) 20m (d) 40m

Answer: d

Explanation:

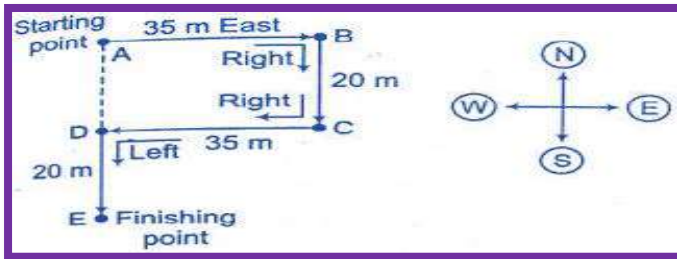

Rajneesh walked 35 m East. He then turned right i.e. facing South walked 20 m. He again turned right i.e. facing West and moved 35 m. So, now he is 20 m far from the starting point.

He then turned left i.e. facing South and moved 20 m.

So, he is in the same line from where he started and 40 m far.

Hence, D is the correct option

Question 38

A rat runs 20m towards East and turns to right, then runs 10m and turns to right, runs 9m and again turns to left, runs 5m and then turns to left, runs 12m and finally turns to left and runs 6m. Now, which direction is the rat facing?

- (a) East
- (b) North
- (c) West
- (d) South

Answer: b

Explanation:

According to the question, the direction diagram is as follows

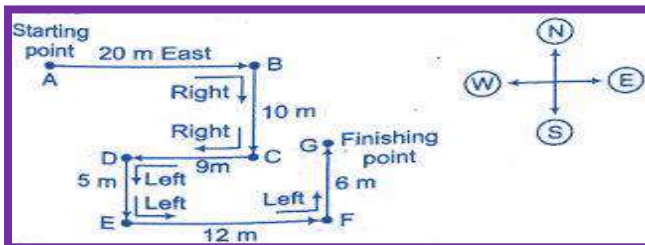

Clearly, the rat is facing North at finishing point.

Question 39

Starting from a point S, Mahesh walked 25m towards South. He turned to his left and walked 50m. He, then again turned to his left and walked 25m. He again turned to his left and walked 60m and reached a point T. How far Mahesh is from point S and in which direction?

- (a) 10m, West
- (b) 25m, North
- (c) 10m, East
- (d) 25m, West

Answer: a

Explanation:

According to the question, the direction diagram is as follows

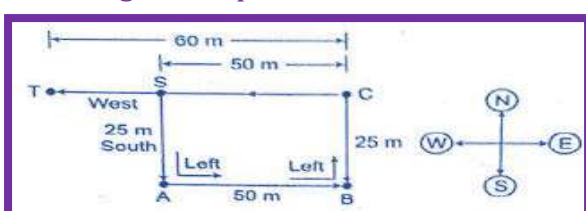

For more Info Visit - www.KITest.in

S = Starting point, T = Finishing point AS = BC = 25m

AB = SC = 50m CT = 60m

Required distance, ST = CT - SC = 60 - 50 = 10m clearly, at point T, Mahesh is 10 m West from S.

Question 40

Village Chimur is 20 km to the North of village Rewa. Village Rahate is 18 km to the East of village Rewa. Village Angne is 12 km to the West of Chimur. If Sanjay starts from village Rahate and goes to village Angne, in which direction is he from his starting point?

- (a) North (b) North-West
(c) South (d) South-East

Answer: B

Explanation:

See the image for locations of various Villages given in the question.

If Sanjay starts from Rahate and goes towards Angne, he is clearly moving in North-West direction.

option B

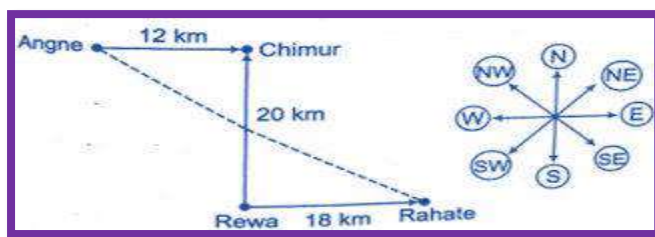

Question 41

A boy is looking for his mother. He went 90 metres in the east before turning to his right. He went 20 metres before turning to his right again to look for his mother at his uncle's place 30 metres from this point. His mother was not there. From here he went 100 metres to his north before meeting his mother in a street. How far did the son meet his mother from the starting point?

- (a) 110m (b) 100m
(c) 90m (d) 240m

Answer: b

Explanation:

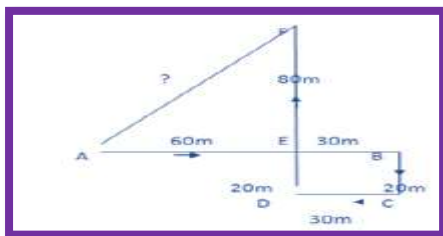

$$(80)^2 + (60)^2$$

$$\sqrt{6400 + 3600} = 100\text{m.}$$

Question 42

Kashmira facing towards south moved straight 8 km and from there turned to her right 90° and travelled 7 km. Then she took a 45° turn to her left and travelled 4 km. Where would she be now with respect to the starting point?

- (a) South (b) South-west
(c) North-east (d) South-east

Answer: b

Explanation:



Question 43

Pinky walks 12m towards southeast and stops at point P and then she walks 24m towards west and again she walks 7m towards northwest direction and stops at point Q. Finally, she walks 5m towards east and stops at point S. She is facing which direction from starting point?

- (a) Northeast (b) Northwest
(c) East (d) Southwest

Answer: d

Explanation:

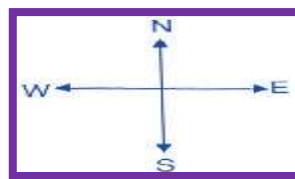
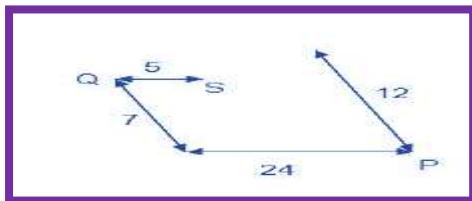

South west

Question 44

A man walks 40m towards north and he turns his left and walked 40m. He then turns his left and walked 15m. He finally turns his right and walked 20m. What is the distance he is from starting point and in which direction?

- (a) 55m, Northwest (b) 36m, Northeast
(c) 65m, Southeast (d) 65m, Northwest

Answer: d

Explanation:

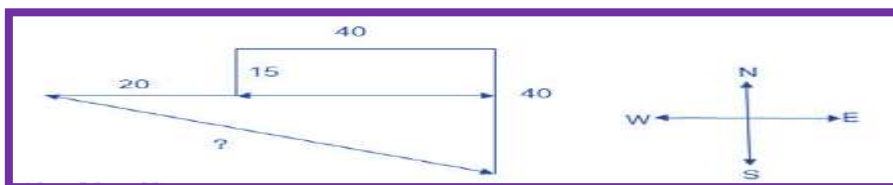

$$\begin{aligned}
 40 + 20 &= 60 \\
 40 - 15 &= 25 \\
 &= \sqrt{60^2 + 25^2} \\
 &= 65\text{m, North West}
 \end{aligned}$$

Question 45

A person starts from point A, walks 5m towards south and reaches point B. He then turns left and walks 8m and reaches point C. He then takes a right turn and walks 6m. He takes a final right turn and walks 8m to reach point D. What is the distance between point C and D?

- (a) 13m (b) 12m
(c) 10m (d) 15m

Answer: c

Explanation:

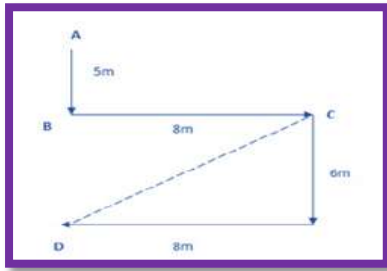

Distance between C and D = $\sqrt{(8^2 + 6^2)} = \sqrt{(64 + 36)} = \sqrt{100} = 10\text{m}$

Question 46

A car started from point P and moves towards east. After moving a distance of 30m, it took a right turn, again after moving 15m, it took a left turn, and again after moving 10m, he took a right turn. Which direction is the car facing now?

- (a) North (b) South
(c) West (d) North-west

Answer: b

Explanation:

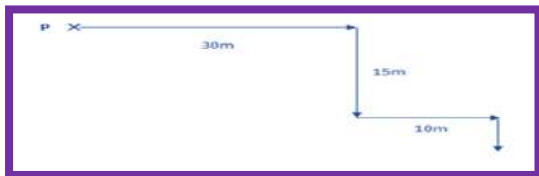

The car is facing the south direction.

Question 47

A directional post is erected on a crossing, in an accident it was turned in such a way that the arrow which was first showing east is now showing north. A passerby went in a wrong direction thinking it is east. In which direction is he actually travelling now?

- (a) North (b) East
(c) West (d) South

Answer: d

Explanation:

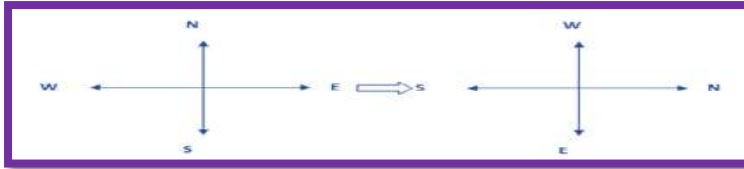

When the arrow turns, north becomes west, east becomes north, south becomes east, west becomes south. So, he travels in south direction.

Question 48

A person walks 22m towards east from point 'A' and turns his left and walks 6m. Again he turns his right and walked 7m and he reached the point 'P' after walking 6m towards his right. Finally he turns right and stop at point 'B' after walking 19m towards west from point P. What is the distance to reach the starting point from PointB?

- (a) 3m (b) 10m
(c) 4m (d) 5m

Answer: b

Explanation:

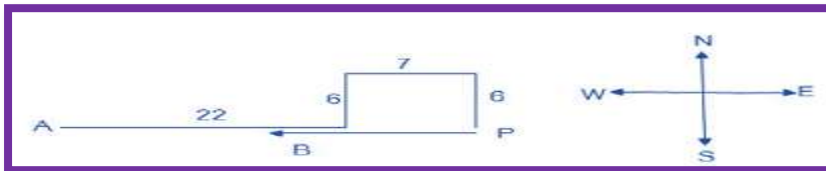

The distance to reach the starting point from PointB is 10m.

Question49

A man started walking from point A and walk towards north and stops at point B. Now he takes a right turn followed by left turn and stops at point C. He finally takes a left turn and stops at point D. Towards which direction the man has to walk from D to B, if he walks 10m before turning eachturn?

- (a) South (b) North
(c) East (d) West

Answer: a

Explanation:



Question 50

Read the following information carefully and answer the questions given below it:
i. M?N means N is to the right of M at a distance of two meter. ii. M*N means N is to the North of M at a distance of two meter. iii.M+N means N is to the left of M at a distance of two meter. iv.M%N means N is to the South of M at a distance of two meter. v. In each of the following questions all persons face North.

Que. If P%Q+R*S then S is in which direction with respect toP?

- (a)South-east (b) East.
(c) North (d)West

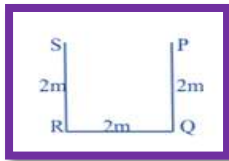
Answer: d**Explanation:****Question 51**

Nakul starts walking from his office towards his house. He starts from the front gate of his office and walks 5 km, then turns left and walks 2 km, then turns left again and walks 4 km, then he turns to his right and walks 3 km, then turns left and walks 1 km and then turns to his left again and walks 4 km, then turns to his right and walks 10 km and finally turns right and walks 3 km and thus reaches the front gate of his house. If Nakul's house is facing south, in which direction did he start walking?

- (a) East (b) West
(c) South (d) North

Answer: a**Explanation:**

PAST EXAMINATION QUESTIONS:

MAY 2018

Question1

Laxman went 15. Kms to North then he turned West and covered Kms. Then he turned South and covered 5 Kms, finally turning to East he covered 10 Kms. In which direction in which he is now moving?

- (a) East (b) West
(c) North (d) South

Answer: c**Explanation:**

**Question2**

A man is facing East, then he turns left and goes to 10 meter then turns right and goes 5 meter then goes 5 meter to the south and from their 5 meter to West. In which direction is he from his original place?

- (a) East (b) North
(c) West (d) South

Answer: b

Explanation:

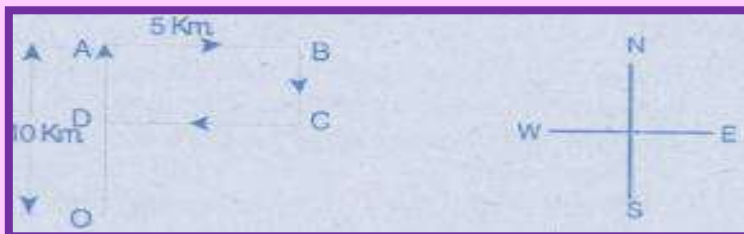

North direction is he forms his original place.

Question3

X Walks southwards and then turns right the left and the right. In which direction is he moving now?

- (a) South (b) North
(c) West (d) South-west

Answer: c

Explanation:



He is moving in west direction.

Question4

Raman starts walking in the morning facing the sun. After sometimes, he turned to the left later again he turned to his left. At what direction is Raman moving

how?

- (a) East (b) West
(c) South (d) North

Answer: b

Explanation:



Raman is moving now in West direction.

Question5

I stand with my right hand extended side-ways towards south. Towards which direction will my back be?

- (a) North (b) West
(c) East (d) South

Answer: b

Explanation:

I stand with my right and extended side- ways towards south. Towards west direction will my back.

Question6

You go north, turn right, then right then go to the left. In which direction are you now?

- (a) North (b) West
(c) East (d) South

Answer: c

Explanation:

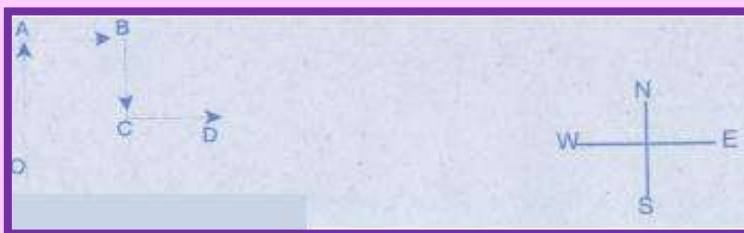

You are in East direction

NOV 2018

Question1

Six flats on a floor in two rows facing North and South are allotted to P, Q, R,

S, T and U. If Q gets a North facing flat and is not next to S. Sand U get diagonally opposite flat. R next to U gets a South facing flat and T gets a North facing flat. Whose flat is between Q and S?

- (a) T (b) U
(c) R (d) P

Answer: a

Explanation:

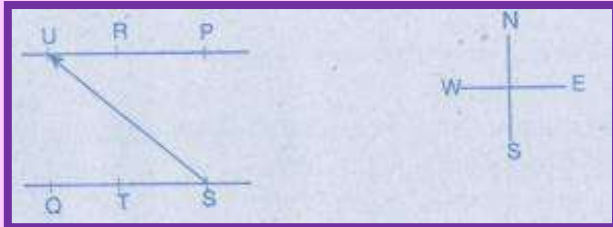

Flat 'T' is b/w Q & S

Question2

Anoop Starts walking towards South after walking 15 meters he turns towards North. After walking 20 metres he turns towards East and walks 10 meters. He then turns towards south and walks 5 meters. In which direction is he from the original position.

- (a) North (b) West
(c) East (d) South

Answer: c

Explanation:

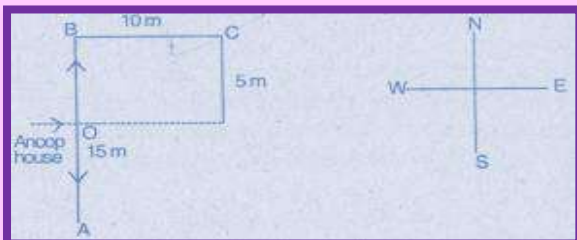

'East direction is he from the original Position'

Question3

Rahim started from point X and walked straight 5 km. West, then turned left and walked straight 2 km. and again turned left and walked straight 7 km. In which direction is he from the point X?

- (a) North-East (b) South-West
(c) South-East (d) North West

Answer: c

Explanation:

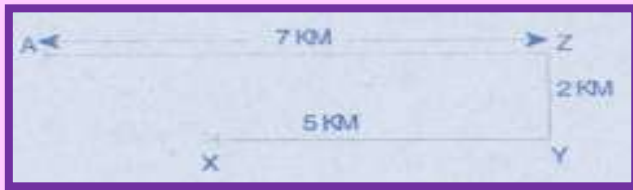
**Question4**

Aman started to walk East, after moving a certain distance, he turns to his right. After moving 6 me distance, he turns to his right again. After moving a little he turns now to his left currently, he is going in direction

- (a) North (b) West
(c) East (d) South

Answer: d

Explanation:

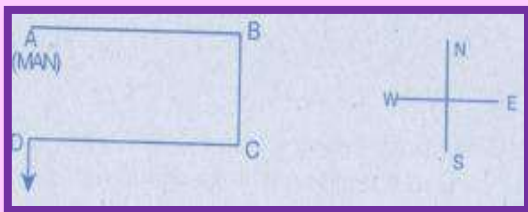

He is going in south direction.

Question5

Manu wants to go to the market. He starts from his house towards North reaches at a crossing after 30m. He turns towards East, goes 10m till the second crossing and turns again, moves towards South straight for 30m where marketing complex exits. In which direction is the market from his house?

- (a) North (b) West
(c) East (d) South

Answer: c

Explanation:

Direction is the market from his house is east.

MAY 2019

Question1

When a person faces north and walk 25 m and she turn left and walk 20m and again turns right and walk 25m, and turns right 25m and turns right and walks 40m in which direction is he now from his starting point.

- (a) North – West (b) North – East
(c) South – West (d) None

Answer: b

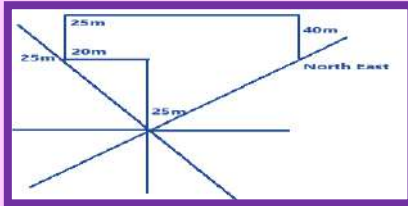
Explanation:**Question2**

Madhuri moved a distance of 75 meters toward north. She then turned to the left and walking for about 25m, turned left again and walks 80m, finally she turned to the right at an angle of 45° . In which direction was she moving finally?

- (a) South – East
(b) South – West
(c) North – west
(d) North – East

Answer: c

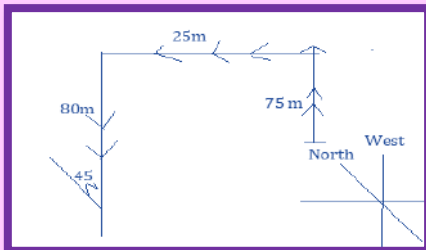
Explanation:**Question3**

A person facing North 70° clock wise direction moving in clockwise and 300° clock wise direction. Now, in which direction he presently facing.

- (a) North-West
(b) South-East
(c) North-East
(d) South -West

Answer: c

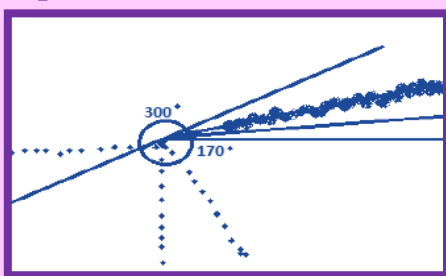
Explanation:**Question4**

Sangeetha leaves from her home. She first walks 30 metres in north – west direction, and then 30 m in south west direction, next she walks 30 metres in south – east direction. Finally, she turns towards her house. In which direction is she moving

- (a) North West
(b) North – East
(c) South – East
(d) South – West

Answer: c

Explanation:

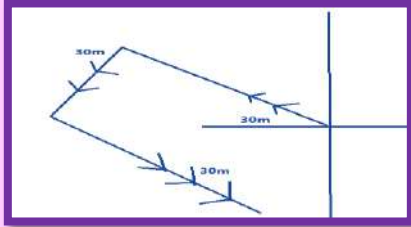

Question5

A man starts his journey facing the sun early morning. He then turns right and walks 2 km. He then walks 3 km after turning right again. Which direction was Ashok from the starting point?

- (a) East
(b) North
(c) West
(d) South

Answer: c

Explanation:

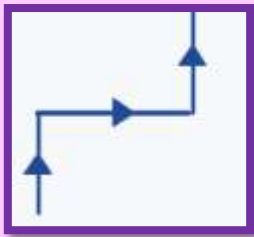

West

NOV 2019

Question1

Mohan started from a point and walked towards west. He took left to reach Sohan's house. In which direction should he move to reach his house:

- (a) North east
(b) South east
(c) South west
(d) North West

Answer : (a)

Explanation:

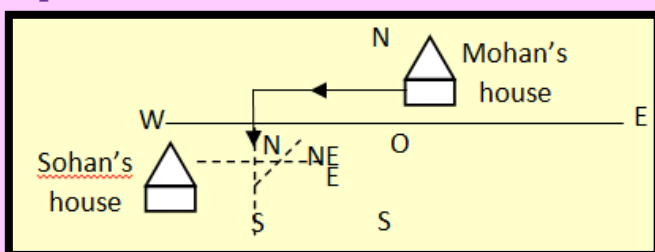

So, Mohan should move in north east direction from Sohan's house to reach his house.

Question2

A man stands on a point and starts walking towards north then turns. Left then turns right and then left in which direction he is moving

- (a) West (b) North
(c) East (d) South

Answer: (a)

So, the man is moving in the west direction.

Question3

A man started from a point facing north then turn left and then left then right. In which direction he is facing now?

- (a) East (b) West
(c) North (d) South

Answer: (b)

Explanation:

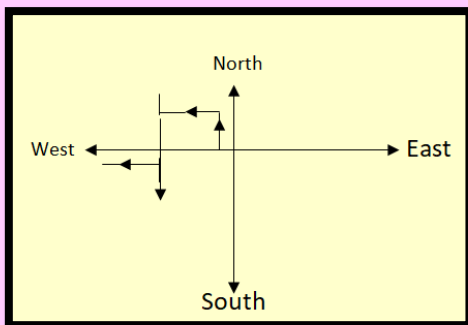

He is facing west.

Question4

Rohan driving cycle from house towards north, turn left and left again, which direction he is facing now?

- (a) East (b) West
(c) North (d) South

Answer: (b)

Explanation:

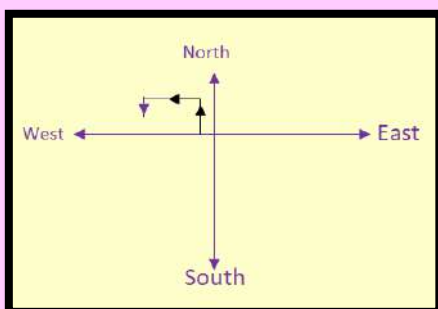

So Rohan is facing towards south.

Question 5

Sun rises behind the tower and sets behind the railway station. In which direction is the tower from railway station?

- (a) North (b) South
(c) East (d) West

Answer: (c)

Explanation:

Since the sun rises behind the tower. So tower is in east direction, railway station is in west direction since sun sets behind it. So tower is in east direction from the railway station.

DEC 2020

Question 1

Rahim faces towards north turning to his right he walks 25 mtrs he then turns to his left and walks 30 mtrs. Next he moves 25 mtrs. To his right he then turns to his right again and walks 55 mtrs. Finally he turns to the right and moves 40 mtrs. In which direction is he now from the starting point?

- (a) South – West (b) South
(c) North – West (d) South – East

Answer: d

Explanation:

Man's movement is as shown in the figure.

∴ Finally he is in south-east direction with respect to A i.e. starting point.

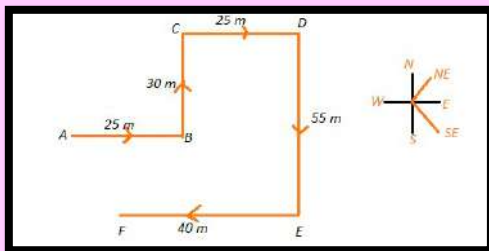
**Question 2**

A man can walk by having long, medium and short steps. He can cover 60 meters by 100 long steps, 100 meters by 200 medium steps and 80 meters by 200 short steps. He starts walking by 5,000 long steps, then he turns left and walk by taking 6,000 medium steps. He then turns right and walk by taking 2,500 short steps.

How far (in meters) is he away from his starting point?

- (a) 5,000m (b) 4,000m
(c) 6,000m (d) 7,000m

Answer: d

Explanation:

Square root of 7000 Step-by-step explanation: For 5000 long steps he travelled $\frac{5000}{100} \times 60$ meters then he turned left and take 6000 medium steps and travelled $\frac{6000}{200} \times 100$ meters then he turns right and travelled $\frac{2500}{200} \times 80$ meters by taking 2500 short steps. As we want to calculate distance from stating pointy It we have to consider it as right angled triangle so we get hypotenuse as square root of (4000+3000)

Question3

One day, Ram left home and cycled 10km southwards, then he turns right and cycled 5km, then he turns right and cycled 10km and then he turns left and cycled 10 km. How many kilometers will he have to cycle to reach his home straight?

- (a) 15km (b) 10km
(c) 20km (d) 25km

Answer: a

Explanation:

According to given fig.,
required distance = A+E
= 5+10
= 15 km

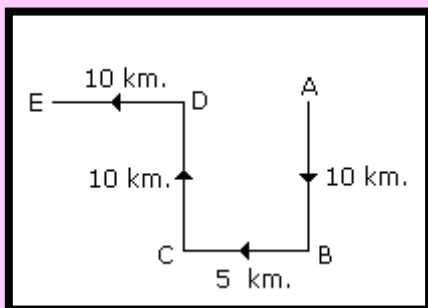

Question 4

You are facing north - east and moved forward 10ms and turned left for 7.5 m what is your position?

- (a) North from initial (b) South from initial
(c) East from initial (d) None

Answer: a

Explanation:

Clearly, The narrator starts from A, moves towards north - east a distance of 10m, upto B, turns left (90o anti clockwise) and moves 7.5 m upto C

Clearly, C lies to the north of A

Also ΔABC is right - angles at B

So $AC^2 = AB^2 + BC^2 = (10)^2 + (7.5)^2$

Explanation:

Given

Initially man is facing west

Then he turns 45° in clockwise(i)

Then 180° in same direction (ii)

and again 270° in anticlockwise direction (iii)

Strictly according to instruction about the movement of the man, draw the diagram.

Hence finally he is facing South West.

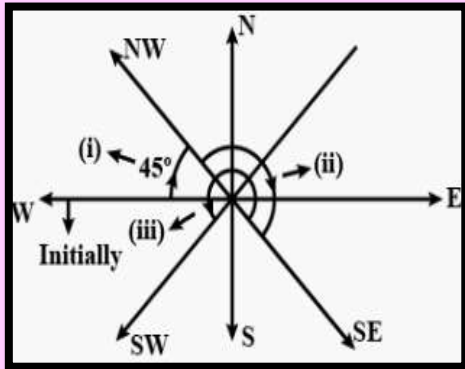
**Question 2**

One day, Ram left home and bi-cycled 10km southwards, turned right and travelled 5 km and turned right and went 10 km he turned left and went 10km. how many kilometers has to cycle to reach his home straight?

(a) 25

(b) 15

(c) 20

(d) 25

Answer: b

Explanation:

**Question 3**

Mr. N walks 19 km toward North. From there she walks 6 km towards East. How far and in which direction is she with reference to her starting point?

(a) 4km West

(b) 6km West

(c) 3km East

(d) 3km North/east

Answer: d

Explanation:

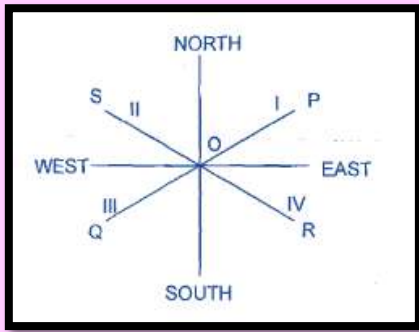

JULY 2021

Question 1

A and B start moving towards each other from two places 200m apart. After walking 60m, B turns left and goes 20m, and then he turns right and goes 40m. He then turns right again and comes back to the road on which he had started walking. If A and B walk with the same speed, what is the distance between them now?

- (a) 80 m
- (b) 70 m
- (c) 40 m
- (d) 60 m

Answer: Options (c)

Explanation:

Distance travelled by A on road = 60 + 20 + 40 + 20 = 140 m

Distance travelled by B on road = 60 + 40 = 100 m

Required difference = 140 - 100 = 40 m

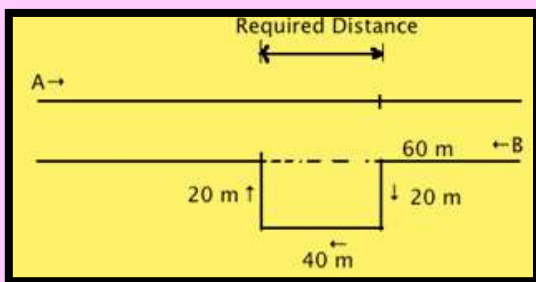

Question 2

There are four towns P,Q,R and T. Q is to the south-west of P, R is to the east of Q and south-east of P, and T is to the north of R in line with QP. In which direction of P is T located?

- (a) North
- (b) North-East
- (c) East
- (d) South-East

Answer: Options (b)

Explanation:

Consider a Cartesian plane taking positive X-axis as East and negative X-axis as West positive Y – axis as North and negative Y – axis as south.

Let us consider that P is at origin. Hence Q would be in the third quadrant; R would be in fourth quadrant because it is in the south-east of P. Finally T would be in the first quadrant as P, Q, T are on the same line. Hence T would be on North-east of P.

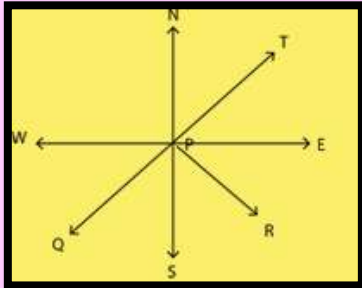

Question 3

Five friends A, B, C, D and E are staying in the same locality. B's house is to the east of A's house and to the north of C's house. C's house is to the west of D's house is in which direction with respect to A's house?

- (a) North-East (b) South-East
(c) North-West (d) South-West

Answer: Options (b)

Explanation:

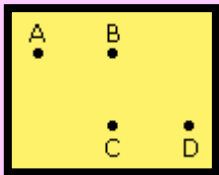

Therefore, D's house is in the South-East direction of A.

Question 4

One morning, after sunrise, Vikram and Shailesh were standing in lawn with their backs towards each other. Vikram's shadow fell exactly towards left hand side. Which direction was Shailesh facing?

- (a) South-West (b) West
(c) South (d) East-South

Answer: Options (c)

Explanation:

Sun rises in the East in morning

Therefore, Shailesh was facing South direction.

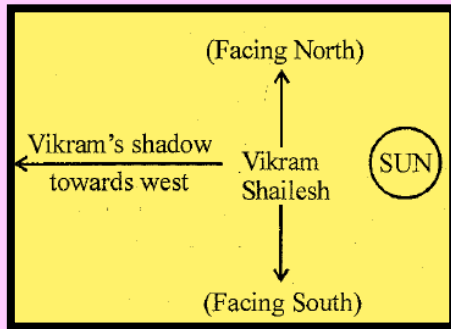

DEC 2021

Question 1

A person walks 1 km (kilometre) towards West and then he turns to South and walks this he turns 5 km. Again, he turns to West and walks 2 km. After this he turns to North and walks 9km. How far is he from his starting point?

- (a) 3km (b) 4 km
(c) 5 km (d) 7km

Answer: c

Explanation:

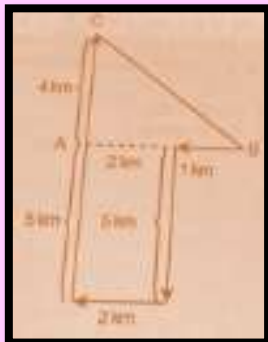

In the ABC, we need to find out BC.

As per Pythagoras' Theorem,

$$BC^2 = AB^2 + AC^2$$

$$BC = \sqrt{AB^2 + AC^2}$$

$$BC = \sqrt{(3)^2 + (4)^2} = 5$$

Question 2

Daily in the morning the shadow of a Clock Tower installed on Railway Station falls on high rise Mall and in evening the shadow of the same Mall falls on the clock tower installed on railway station exactly. So in which direction is Clock Tower to Mall?

- (a) Eastern side (b) Western side
(c) Northern Side (d) Southern side

Answer:**Explanation:**

Sun rises in the East. Therefore, in the morning, the shadow of the things located in East will fall towards West and in the evening the shadow of the things located in west will fall towards East.

Here, since the shadow of the clock tower is located on the Eastern side.

Question 3

R's office is 4 km. in East direction from his home and club is 4 km in North direction from his home. On midway from office to club, R starts moving towards his home. In which direction is he facing his back?

- (a) South-East (b) North-West
(c) North-East (d) South-West

Answer: c**Explanation:**

Clearly, the back of R is towards North-East.

Question 4

A man starts from a point, walks 4 miles towards North and turns left and walks 6 miles, turns right and walks for 3 miles and again turns right and walks 4 miles and takes rest for 30 minutes. He gets up and walks straight 2 miles in the same direction and turns right and walks one mile. What is the direction he is facing?

- (a) North (b) South- East
(c) South (d) West

Answer: b**Explanation:**

Therefore, he is facing South direction.

Question 5

The hour hand of a clock is in west direction when time is 3:00 clock. What is the

direction of minutes hand when time is 6:45?

- (a) East (b) West
(c) North (d) South

Answer: a

Explanation:



JUNE 2022

Question 1

A sign board pointing direction towards north due to heavy wind. The points of sign words shows west instead of North. If a person moves to same direction of pointer. He moves 100 meter than turn left, and moves 100 meter than again turn left and move 100 meter than he turn right & moves 100 meter. In which direction he is now?

- (a) West (b) East
(c) North (d) South

Answer: Options (d)

Explanation:

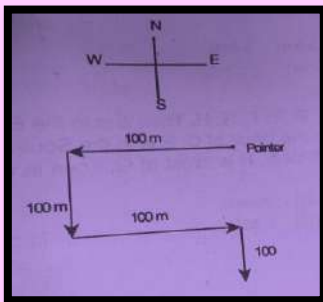

He is south direction from starting point 'Now'

Question 2

If Ramu faces West and moved 5 km in the direction then takes a left turn and moves 10 km then take another left turn and moves 15 km in same direction then moves 10 km in the north direction and reaches point A. What is distance between the starting point and A and in which direction is Ramu facing now?

- (a) 10 km, North (b) 5 km, South
(c) 10 km, South (d) 5 km, North

Answer: Options (a)

Explanation:

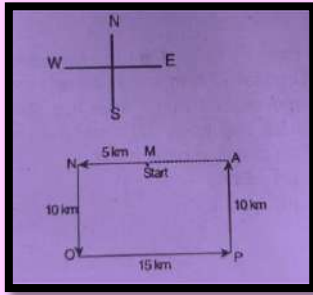

Distance b/w M and A = $15 \text{ km} - 5 \text{ km}$

Direction \rightarrow (North)

Question 3

If there are 8 polls from A, B, C, D, E, F, G, H. Then B is to the East of A, C is to the South of B, D is to the West of C, E is to the South of D, F is to the East of E, G is South of F, H is West of G. Then in which direction is H in respected to A.

- (a) North (b) West
(c) South (d) East

Answer: Options (c)

Explanation:



'H' is the South of 'A'

Question 4

One day Ram Left home and cycled 10 km southward, turned right and cycled 5 km and turned right and cycled 10 km and turned left to cycle 10 km. How many kilometres will he have to cycle to reach his home?

- (a) 10 (b) 20
(c) 15 (d) 25

Answer: Options (c)

Explanation:

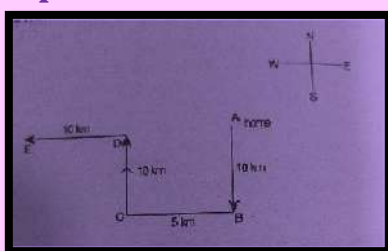

Question 5

A person facing in North moves 70° in clockwise direction. He again moved 300° in ant clockwise direction. In which direction is he facing now?

- (a) North - West
 (b) South - East
 (c) North - East
 (d) South - West

Answer: Options (b)

Explanation:

Person facing south - east

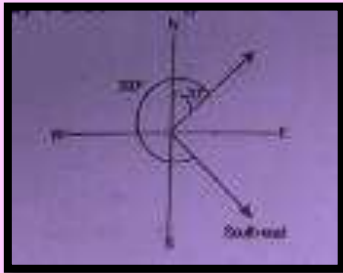

DEC 2022

Question 1

A man is facing west. He turns 45 degree in the clockwise direction and then another 180 degree in the same direction and then 270 degree in the anticlockwise direction Find which direction he is facing now?

- a) South-East
 b) West
 c) South
 d) South-West

Answer: Options (d)

Explanation:

Given:

A man stands facing West. He turns 45° in the clockwise direction and then another 180° in the same direction and then 270° in the anticlockwise direction.

According to the given information, we get the following figure,

Therefore, the man is now facing the South - West direction. Hence, the correct answer is "South - West".

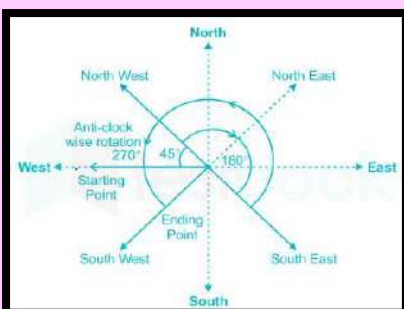

Question 2

Radha moves towards South-East a distance of 7 km. then she moves towards West and travels a distance of 14 km. From here she moves towards North-West a distance of 7 km and finally she moves a distance of 4km towards east. How far is she now from the starting point?

- a) 3 km
b) 4 km
c) 10 km
d) 11 km

Answer: Options (c)

Explanation:

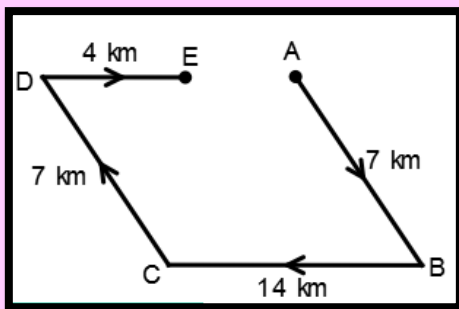

Required Distance

$$\begin{aligned} &= AE \\ &= 14 - 4 \\ &= 10 \text{ km} \end{aligned}$$

Question 3

P, Q, R and S are playing a game of carom P, R, and S, Q are playing a game of carom P, R and S, Q are partners. 'S' is to the right of 'R'. If 'R' is facing west, then 'Q' is facing which direction?

- a) South
b) North
c) East
d) West

Answer: Options (b)

Explanation:

Hence option b is correct

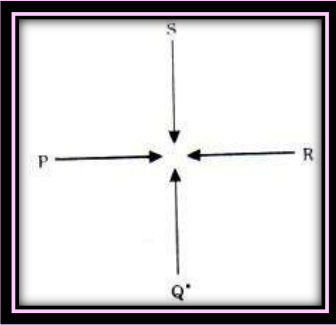

Question 4

One morning a boy starts walking in a particular direction for 5 km and then takes a left turn and walks another 5 km thereafter he again takes left turn and walks another 5 km and at last he takes right turn and walks 5 km. Now he sees his shadow in front of him. What direction he did start Initially?

- | | |
|----------|----------|
| a) South | b) North |
| c) West | d) East |

Answer: Options (b)

Explanation:

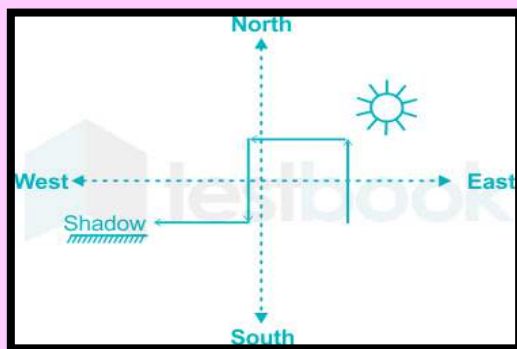

If he sees his shadow in front of him in the morning, when the sun is in east, he is facing in the west. So as you see in the figure he must start in the direct on the north so that he faces in the direction of his shadow. Hence north is the answer.

Question 5

It is 3' o'clock in a watch. If the minute hand points towards the North-East then the hour hand will point towards the

- | | |
|---------------|---------------|
| a) South | b) South-west |
| c) North-West | d) South-East |

Answer: Options (d)

Explanation:

At 3 O'clock, the hour hand is 90° ahead of the minute hand clockwise. Since the minute hand is towards North-East, so the hour hand points towards South - East.

CHAPTER - 11
SEATING ARRANGEMENTS

VARIOUS PATTERN OF SITTING
ARRANGEMENTS

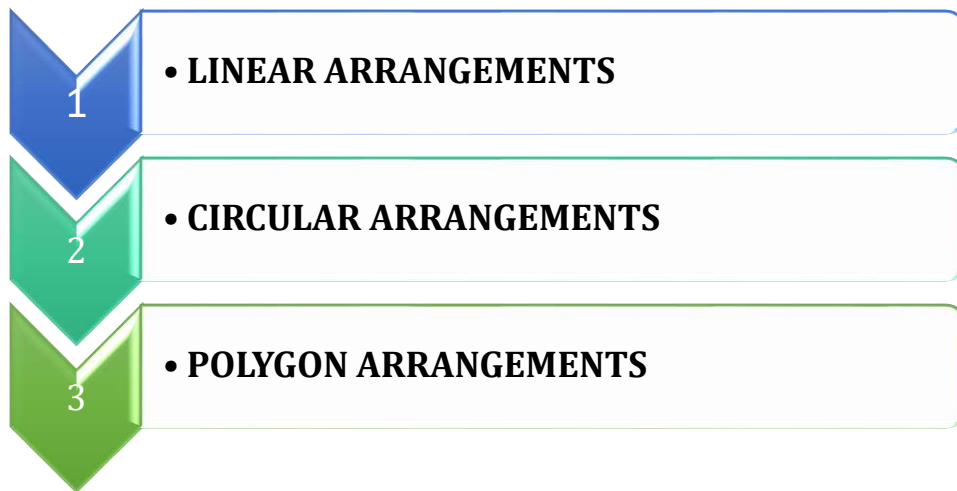

LINEAR ARRANGEMENTS	We arrange objects or persons in a line or row. The arrangement is done only on one 'axis' and hence, the position of persons or objects assumes importance in terms of order like positions. In this type of arrangement, we take directions according to our left and right.	
	One Row Sequence	When direction of face is not clear.
	Two Row Sequence	When direction of face is clear at every level to each and every person.
<p>Steps to Solve the Linear Arrangements:</p> <p>(a) Identify the number of objects and their names.</p> <p>(b) Use pictorial method to represent the people or objects and their positions.</p> <p>(c) Arrange the information with relevant facts and their positions and try to find out the solution.</p>		

CIRCULAR ARRANGEMENT

- (d) Answer the questions based on the arrangement having made. some persons are sitting around a circle and they are facing the center

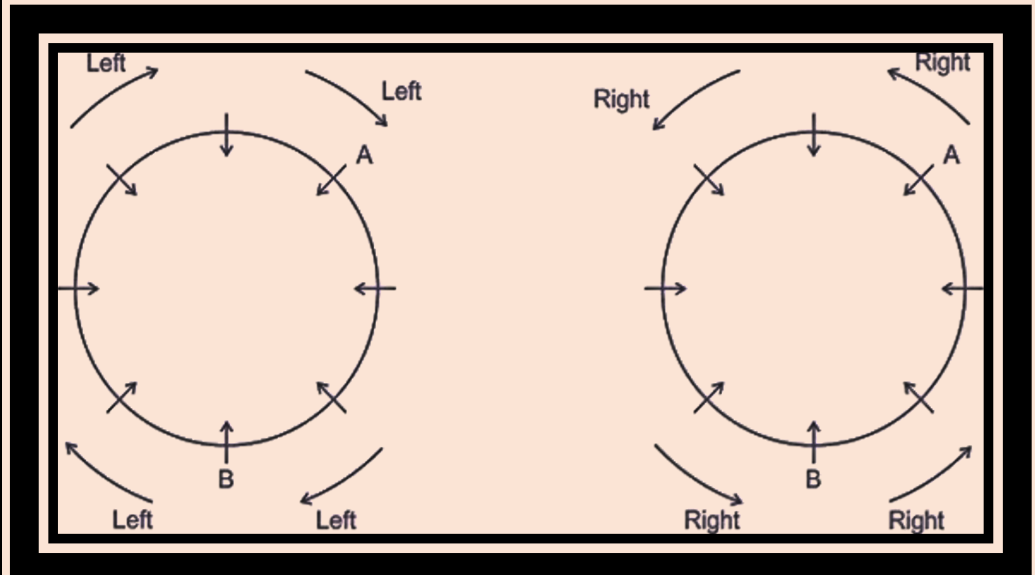

Question 1

Four Children's are sitting in a row. A is occupying seat next to B but not next to C. If C is not sitting next to D? Who is occupying seat next to adjacent to D.?

- (a) B (b) B and A
(c) Impossible to tell (d) A

Answer: D

Explanation:

The arrangements as per given information is possible only if C is sitting next to B and D is sitting next to A.

Therefore, two possible arrangements are C, B, A, D, or D, A, B, C. Clearly, only A is sitting adjacent to D.

Question 2

P, Q, R, S, T, U, V and W are sitting in a row facing North.

- (A) P is fourth to the right of T

(B) W is Second to the left of S

(C) R and U, which are both at the ends, are neighbours of Q and T respectively

(D) W is immediate left of P and P is the neighbour of Q

who are the immediate neighbours of W?

(a) Q and V

(b) V and R

(c) V and P

(d) U and P

Answer: C

Explanation:

Person: P, Q, R, S, T, U, V, W

Facing north

P is fourth to right of T

T _ _ _ P

W is fourth to the left of S

S _ _ W

R and U, which are both at the ends are neighbours of Q and T respectively

U T _ _ _ P Q R

W is immediate left of P and P is neighbour of Q

U T S _ W P Q R

U T S V W P Q R

Hence immediate neighbour of w are V and P

Therefore option c is the right answer.

Question 3

A, P, R, X, S and Z are sitting in a row. S and Z are in the centre. A and P are at the ends. R is sitting to the left of A. Who is to the right of P ?

a) A

b) X

c) S

d) Z

Answer: B

Explanation:

The seating arrangement is as follows:



Therefore, right of P is X

Question 4

A, B, C, D and E are sitting on a bench. A is sitting next to B, C is sitting next to D, D is not sitting with E who is on the left end of the bench. C is on the second position from the right. A is to the right of B and E. A and C are sitting together. In which position A is sitting?

(a) Between B and D

(b) Between B and C

(c) Between E and D

(d) Between C and E

Answer: B

Explanation:



Therefore, A is sitting in between B and C

Question 5

P, Q, R, S, T, U, V and W are sitting round the circle and are facing the centre:

P is second to the right of T who is the neighbour of R and V.

S is not the neighbour of P.

V is the neighbour of U.

Q is not between S and W. W is not between U and S

According to this answer bellowed Questions:

5.1 Which two of the following are not neighbours?

- (a) RV (b) UV
(c) RP (d) QW

Answer:A

Explanation:

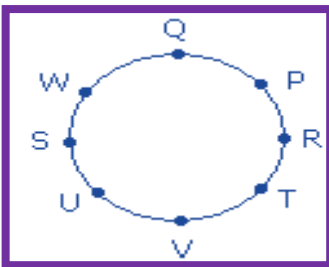

5.2. Which one is immediate right to the V ?

- (a) P (b) U
(c) R (d) T

Answer:D

Explanation:

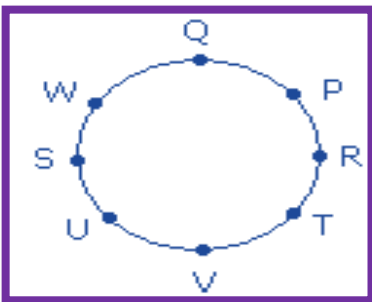

5.3. Which of the following is correct?

- (a) P is to the immediate right of Q (b) R is between U and V
(c) Q is to the immediate left of W (d) U is between W and S

Answer: C

Explanation:

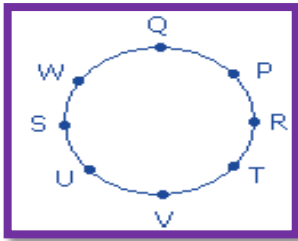

5.4 What is the position of S?

- (a) Between U and V
- (b) Second to the right of P
- (c) To the immediate right of W
- (d) Data inadequate

Answer:C

Explanation:

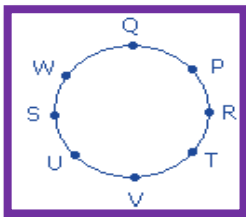

Question 6

6.1 Five girls are sitting on a bench to be photographed. Seema is to the left of Rani and to the right of Bindu. Mary is to the right of Rani. Reeta is between Rani and Mary. According to this answer bellowed

Questions:

6.1 Who is sitting immediate right to Reeta?

- (a) Bindu
- (b) Rani
- (c) Mary
- (d) Seema

Answer:C

Explanation:

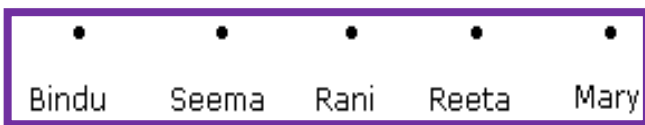

Mary is sitting immediate right to Reeta.

6.2 Who is in the middle of the photograph?

- (a) Bindu
- (b) Rani
- (c) Reeta
- (d) Seema

Answer:B

Explanation:



Rani is in the middle of the photograph.

6.3 Who is second from the right?

- (a) Mary
(c) Reeta
- (b) Rani
(d) Bindu

Answer: C**Explanation:**

Reeta is sitting second from the right.

6.4. Who is second from the left in photograph?

- (a) Reeta
(c) Bindu
- (b) Mary
(d) Seema

Answer: D**Explanation:**

Seema is sitting second from the left in photograph.

Question 7

Six friends are sitting in a circle and are facing the centre of the circle. Deepa is between Prakash and Pankaj. Priti is between Mukesh and Lalit. Prakash and Mukesh are opposite to each other.

7.1. Who is sitting right to Prakash?

- (a) Mukesh
(c) Pankaj
- (b) Deepa
(d) Lalit

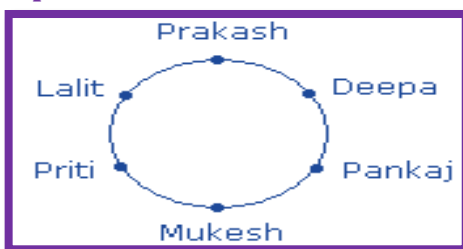
Answer: D**Explanation:**

Hence, Lalit is sitting right to Prakash.

7.2 Who is just right to Pankaj?

- (a) Deepa
(c) Prakash
- (b) Lalit
(d) Priti

Answer: A**Explanation:**

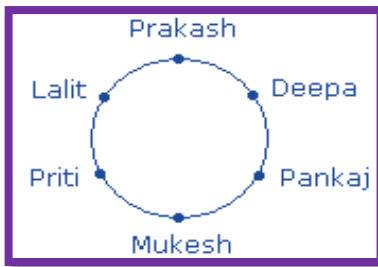

Hence, Deepa is sitting just right to Pankaj.

7.3 Who are the neighbours of Mukesh?

- (a) Prakash and Deepa
- (c) Priti and Pankaj

- (b) Deepa and Priti
- (d) Lalit and Priti

Answer:C

Explanation:

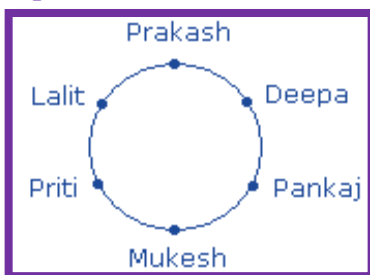

Hence, Priti and Pankaj are the neighbours of Mukesh.

7.4 Who is sitting opposite to Priti?

- (a) Prakash
- (c) Pankaj

- (b) Deepa
- (d) Lalit

Answer:B

Explanation:

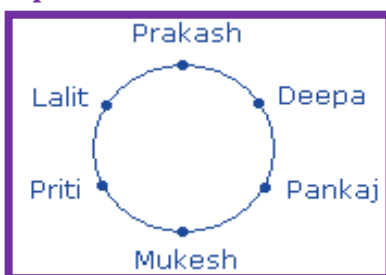

Hence, Deepa is sitting opposite to Priti.

Question 8

In an Exhibition seven cars of different companies - Cadillac, Ambassador, Fiat, Maruti, Mercedes, Bedford and Fargo are standing facing to east in the following order :

Cadillac is next to right of Fargo.

Fargo is fourth to the right of Fiat.

Maruti car is between Ambassador and Bedford.

Fiat which is third to the left of Ambassador is at one end.

8.1 Which of the cars are on both the sides of Cadillac car?

- (a) Ambassador and Maruti
 (b) Maruti and Fiat
 (c) Fargo and Mercedes
 (d) Ambassador and Fargo

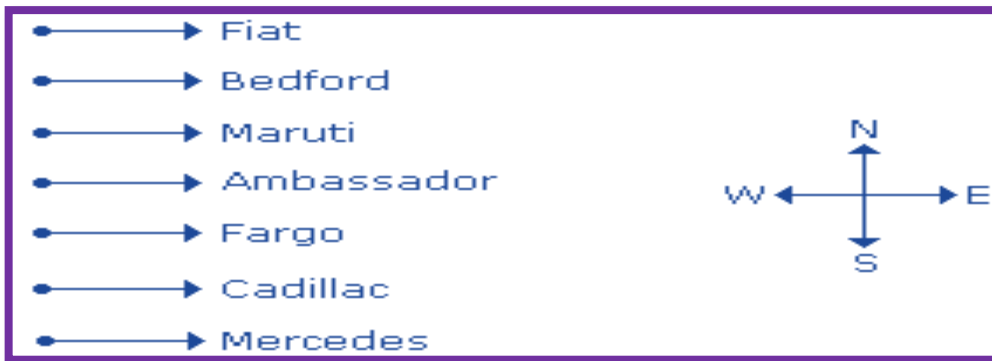
Answer:C**Explanation:**

Fargo and Mercedes are on both the sides of cadillac car.

8.2 Which of the following statement is correct?

- (a) Maruti is next left of Ambassador
 (b) Bedford is next left of Fiat.
 (c) Bedford is at one end.
 (d) Fiat is next second to the right of Maruti.

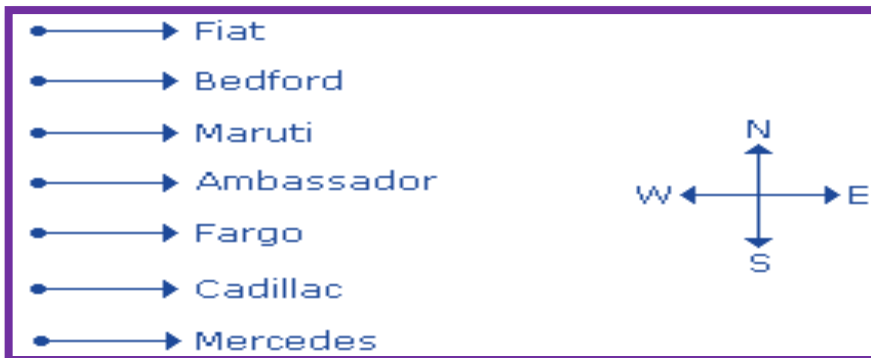
Answer:A**Explanation:**

Therefore, Maruti is next left of Ambassador.

8.3 Which one of the following statements is correct?

- (a) Fargo car is in between Ambassador and Fiat
 (b) Cadillac is next left to Mercedes car.
 (c) Fargo is next right of Cadillac.
 (d) Maruti is fourth right of Mercedes

Answer:B**Explanation:**



Therefore, Cadillac is next left to Mercedes car.

8.4 Which of the following groups of cars is to the right of Ambassador?

- (a) Cadillac, Fargo and Maruti
 (b) Mercedes, Cadillac and Fargo
 (c) Maruti, Bedford and Fiat
 (d) Bedford, Cadillac and Fargo

Answer:B

Explanation:

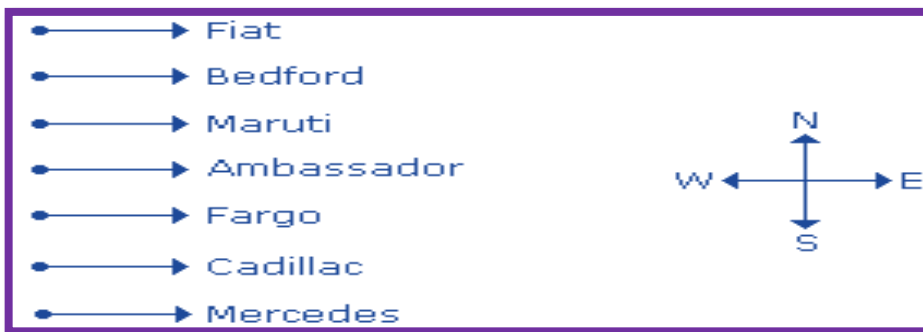

Mercedes, Cadillac and Fargo cars are to the right of Ambassador.

8.5 Which one of the following is the correct position of Mercedes?

- (a) Next to the left of Cadillac
 (b) Next to the left of Bedford
 (c) Between Bedford and Fargo
 (d) Fourth to the right of Maruti.

Answer:D

Explanation:



The correct position of Mercedes is fourth to the right of Maruti.

Question 9

Six friends P, Q, R, S, T and U are sitting around the hexagonal table each at one corner and are facing the center of the hexagonal. P is second to the left of U. Q is neighbor of R and S. T is second to the left of S.

9.1 Which one is sitting opposite to P?

- (a) R
(c) Between Bedford and Fargo

- (b) Q
(d) Fourth to the right of Maruti.

Answer:D

Explanation:

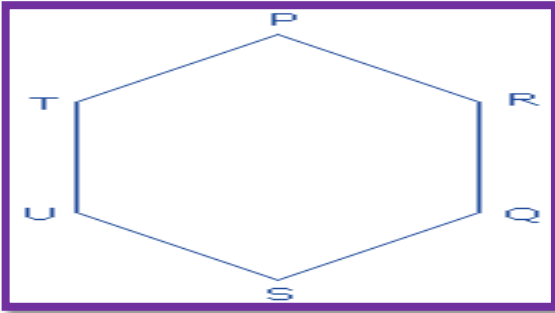

S is sitting opposite to P.

9.2 Who is the fourth person to the left of Q?

- (a) P
(c) R
- (b) U
(d) Data inadequate

Answer:A

Explanation:

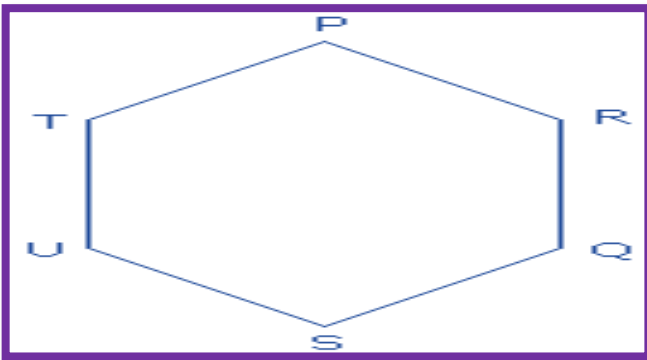

P is the fourth person to the left of Q.

9.3 Which of the following are the neighbours of P ?

- (a) U and P
(c) U and R
- (b) T and R
(d) Data inadequate

Answer:B

Explanation:

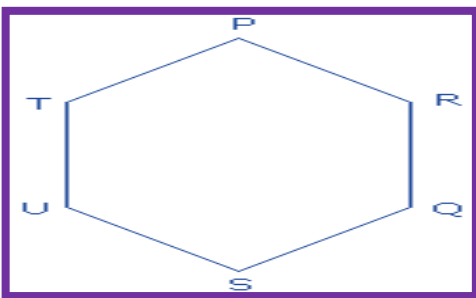

T and R are the neighbours of P.

9.4. Which one is sitting opposite to T?

- (a) R
- (c) Cannot be determined

- (b) Q
- (d) S

Answer: B

Explanation:

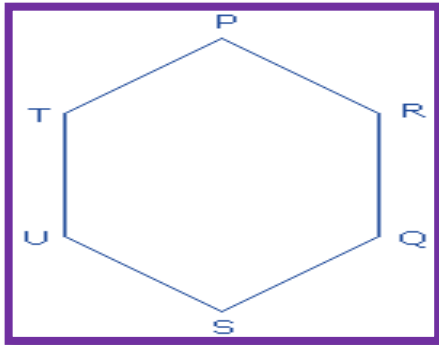

Q is sitting opposite to T.

Question 10

Each of these questions are based on the information given below:

A, B, C, D and E are five men sitting in a line facing to south - while M, N, O, P and Q are five ladies sitting in a second line parallel to the first line and are facing to North.

B who is just next to the left of D, is opposite to Q.

C and N are diagonally opposite to each other.

E is opposite to O who is just next right of M.

P who is just to the left of Q, is opposite to D.

M is at one end of the line

10.1 Who is sitting third to the right of O?

- (a) Q
- (c) M
- (b) N
- (d) Data inadequate

Answer: B

Explanation:

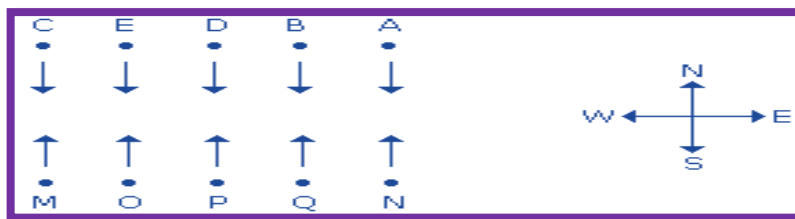

10.2 If B shifts to the place of E, E shifts to the place of Q, and Q shifts to the place of B, then who will be the second to the left of the person opposite to O?

- (a) Q
- (c) E
- (b) P
- (d) D

Answer: A

Explanation:

Initial arrangement:

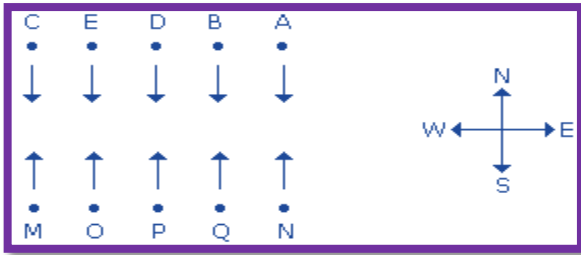

New arrangement after shifting:

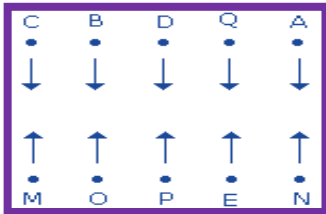

B is opposite to O and second person left to B is Q.

10.3. Which of the following pair is diagonally opposite to each other?

- (a) EQ
- (b) BO
- (c) AN
- (d) AM

Answer:D

Explanation:

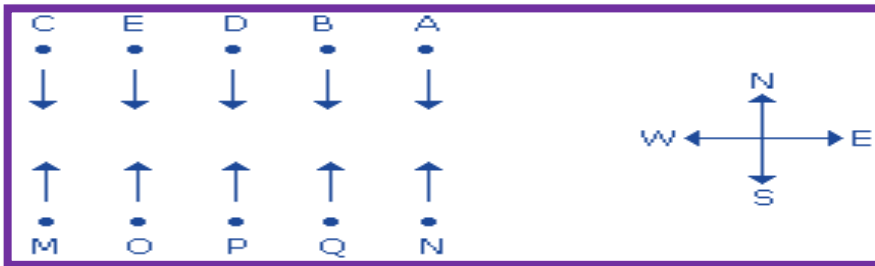

10.4. If O and P, A and E and B and Q interchange their positions, then who will be the second person to the right of the person who is opposite to the person second of the right of P ?

- (a) D
- (b) A
- (c) E
- (d) O

Answer:B

Explanation:

Old arrangement:

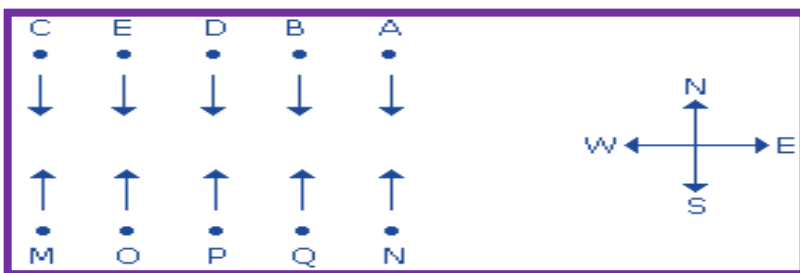

New arrangement:

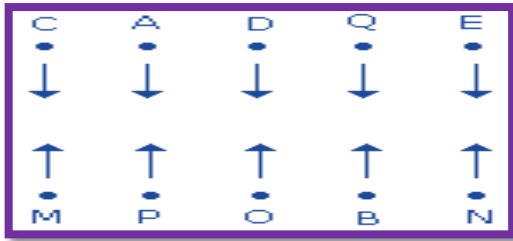
**Question 11**

Study the following information carefully and answer the question:

Group of girls gossip with each other. All are sitting surrounding a round table. The name of the girls are Shiksha, Radha, Chinu, Snigdha, and Rani. It is not necessary that they are sitting in the order of the name as mentioned here. Radha is Second to the right of Rani. Radha sits near Snigdha

11.1 Who sits to the left of Shiksha?

- (a) Rani (b) Radha
(c) Chinu (d) Snigdha

Answer: A

Explanation:

After observation, we can conclude that the sitting arrangement is like this –

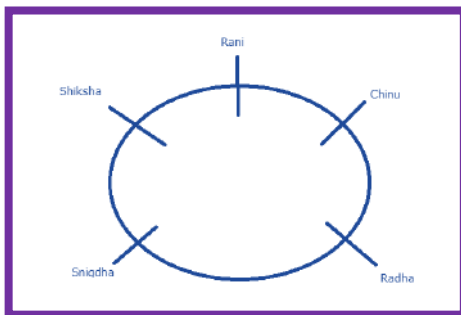

So, Rani sits to the left of Shiksha.

11.2 If Radha and Snigdha change their places, then who will be second to the left of Rani?

- (a) Radha (b) Snigdha
(c) Shiksha (d) None of the above

Answer: B

Explanation

Second to the left of Rani will be Snigdha. Hence, option B is correct.

11.3 How many girls are there in between Shiksha and Chinu if we count anti clockwise?

- (a) 1 (b) 2
(c) 3 (d) None of the above

Answer: B

Explanation –

Only two girls are there in between Shiksha and Chinu if we count anti clockwise?

Question 12

Six army majors are sitting around a circular table and discussing about stopping infiltration across the border. Major Bakshi is sitting between Major Kalia and Major

Sodhi. Major Kalia is sitting immediate left of Major Bakshi. Major Kumar is sitting second to the left of Major Kalia. Major Nanda is sitting between Major Kumar and Major Sodhi.

12.1 What is the position of Major Batra?

- (a) Major Batra is sitting between Major Kumar and Major Kalia. (b) Major Batra is sitting to the left of Major Kalia.
 (c) Major Batra is sitting to the immediate right of Major Kumar (d) All the above are true.

Answer:D

Explanation -

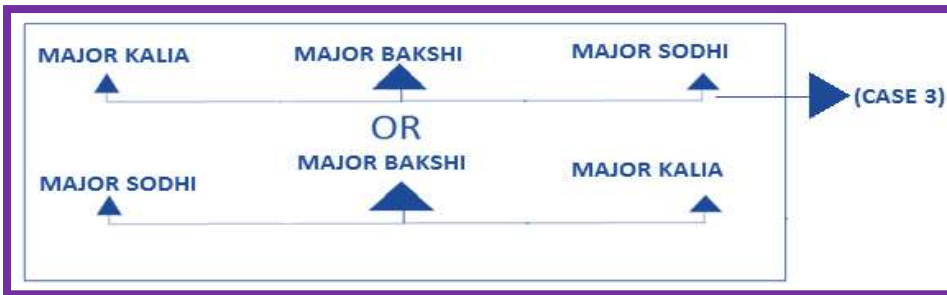

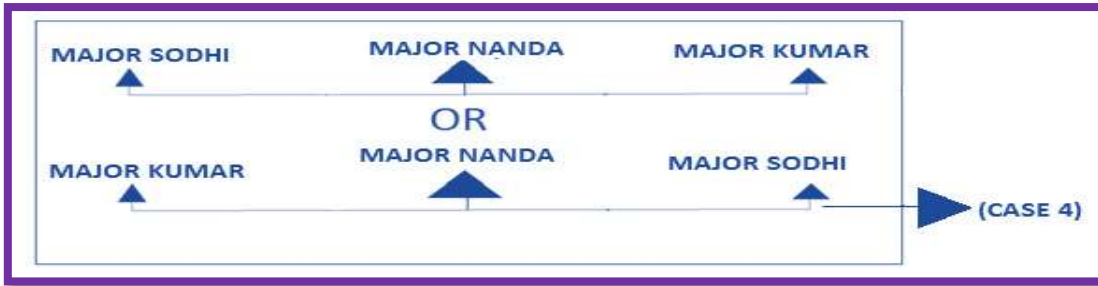

By applying (CASE 1), (CASE 2), (CASE 3) and (CASE 4), we get

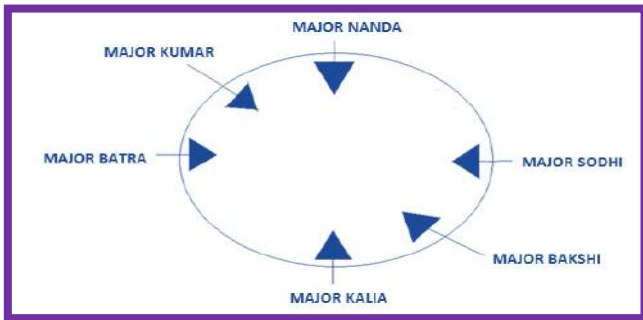

All the options (A),(B) and (C) satisfy our condition. Therefore option (D) is correct.

12.2 Who is sitting to the immediate left of Major Kumar?

- (a) Major Bakshi
- (b) Major Batra
- (c) Major Nanda
- (d) Major Sodhi

Answer: C

Explanation:

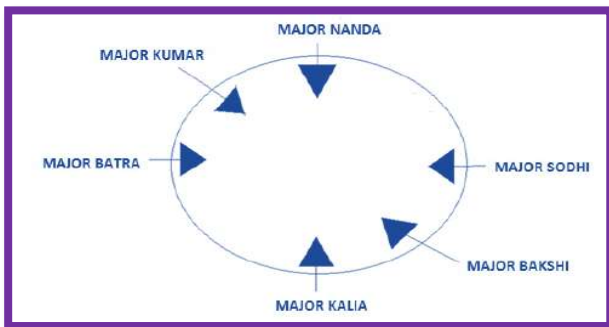

According to the diagram –

By observing the diagram, we can clearly say that Major Nanda is sitting to the immediate left of Major Kumar.

12.3 Who is sitting to the immediate right of Major Kalia?

- (a) Major Nanda
- (b) Major Kumar
- (c) Major Kalia
- (d) Major Bakshi

Answer: D

Explanation –

According to the diagram –

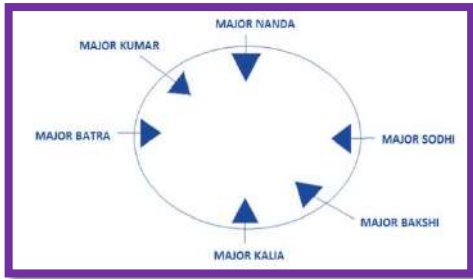

By observing the diagram, one can easily conclude that major Bakshi is sitting to the immediate right of Major Kalia.

12.4 Which of the following statement is true?

- (a) Major Sodhi is sitting second to the left of Major Bakshi.
- (b) Major Kalia is sitting between Major Nanda and Major Kumar
- (c) Major Batra is sitting to the left of Major Kalia
- (d) Major Nanda is sitting to the left of Major Kalia.

Answer:C

Explanation -

According to the diagram -

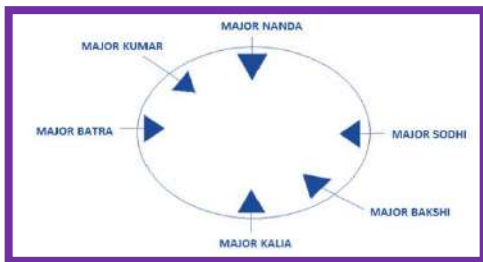

By observing the diagram, we can conclude that options (A), (B) and (D) do not satisfy the condition. But option (C) does.

12.5 How many Majors are sitting between Major Sodhi and Major Kumar, if counted in clockwise direction?

- (a) Six
- (b) Two
- (c) Three
- (d) Five

Answer:C

Explanation -

According to the diagram -

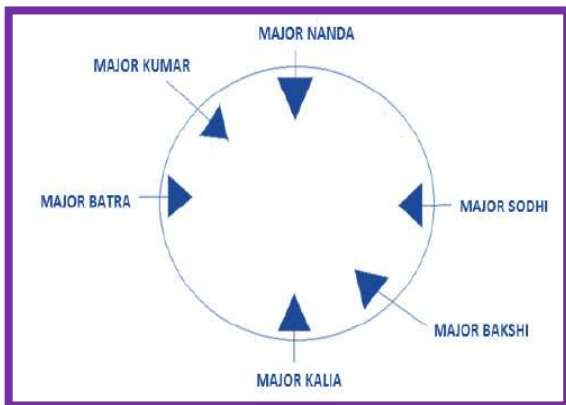

Major Bakshi, Major Kalia and Major Batra are the three majors sitting between Major Sodhi and Major Kumar.

12.6 What is Major Batra position with respect to Major Sodhi?

- (a) Second to the left (b) Immediate Right.
(c) Fourth to the Right (d) Third to the left

Answer:D

Explanation -

According to the diagram -

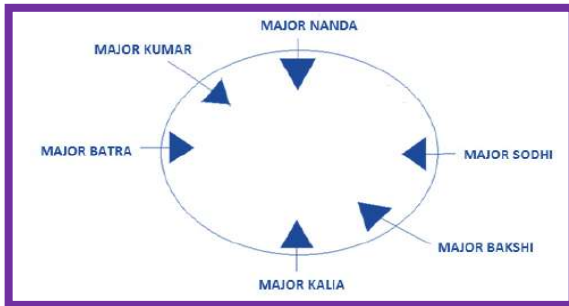

By observing the diagram, we can conclude that Major Bakshi is sitting to the immediate left of Major Sodhi. Major Kalia is sitting to the second left of Major Sodhi and Major Batra is sitting third to the left of Major Sodhi. So, our required answer is option (D).

Question 13

Study the given information carefully and answer the following questions.

Four friends U, V, W and X are sitting in a row and facing towards north direction. U and X are sitting at two extreme ends. V is sitting between U and W. V is sitting second to the left of X.

13.1 Who is sitting to the immediate right of V?

- (a) X (b) U
(c) W (d) None of these

Answer:C

Explanation:

According to the diagram -

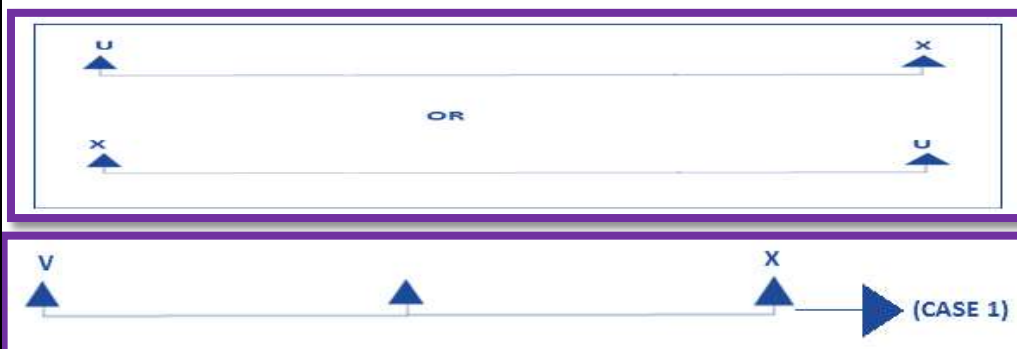

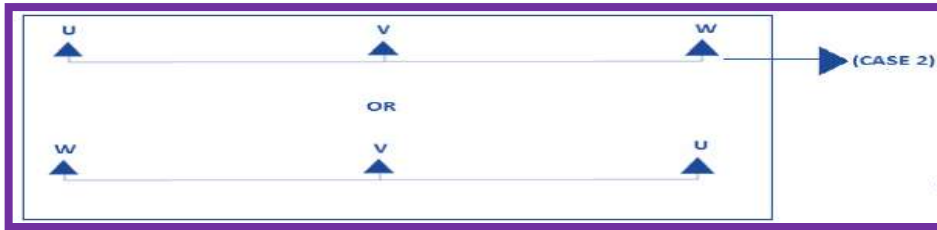

By applying (CASE 1) and (CASE 2), we get



From the diagram, it is clear that W is sitting immediate right of V.

13.1 Who is sitting to the immediate left of X?

- (a) W (b) U
(c) V (d) None of these

Answer:A

Explanation -

According to the diagram -



By observing the diagram, we can conclude that W is sitting immediate left of X.

13.2 What is the number of People sitting between X and U?

- (a) Three (b) Five
(c) One (d) Two

Answer:D

Explanation -

According to the diagram -



By observing the diagram, we can conclude that V and W are the two people sitting between U and X.

13.3 Which statement is true?

- (a) X is sitting to the left of U (b) U and X are sitting at extreme ends.
(c) U is sitting between V and X (d) Three people are sitting between U and X

Answer:B

Explanation -

According to the diagram -



U and X are the two people sitting at extreme ends whereas V is sitting to the right of U and W is sitting to the left of X.

13.4 Which of the following pairs is the first person sitting to the immediate right of second person?

- (a) VW (b) WV
(c) UV (d) None of these

Answer:B

Explanation -

According to the diagram -



Here in option (B), the second person is V and the first person is W. So according to the condition, that is the first person sitting to the immediate right of the second person, only satisfies in option (B).

13.5 How many persons are there to the right of U?

- (a) Two (b) Four
(c) One (d) Three

Answer:D

Explanation -

According to the diagram -



By observing the diagram, we can conclude that three-person V, W and X are sitting to the right of U.

Question 14

Study the following information carefully and answer the questions given below.

Certain number of people was sitting in a circle facing towards the Centre. Some of the person's arrangements are known. A was sitting fourth to the left of B. J was sitting seventh to the right of A. Number of person sitting between A and B was same as the number of persons sitting between A and F. J was the neighbor of D who sits at the seventh position from F (either left or right of F). Number of person sitting between F and M was same as the number of persons sitting between M and D. K was the neighbor of J. M is not the immediate neighbor of A.

14.1 What is the position of M with respect to A?

- (a) Third to the left (b) Immediate right
(c) Seventh to the right (d) Second to the right

Answer:D

14.2 How many persons were sitting in a circle?

- (a) 07 (b) 08
(c) 16 (d) 19

Answer:D

14.3. How many known persons were sitting between A and J when counted from left of A?

- (a) Three (b) Four

(c) Five
Answer:D

(d) Two

14.4. Who sits second to the right of B?

- (a) K
- (b) F
- (c) A
- (d) J

Answer:A

14.5 If C sits exactly between A and K when counted from right of A, then what is the position of C with respect to D?

- (a) Fifth to the left
- (b) Fourteenth to the right
- (c) Sixteenth to the right
- (d) Either (a) or (b)

Answer: D

Explanation of Question 26 is:

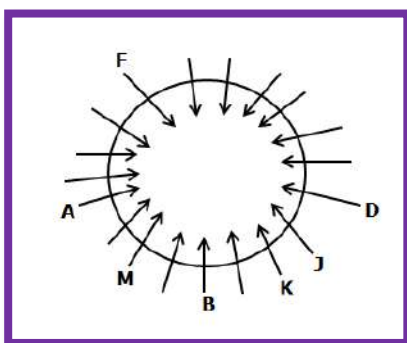

A certain number of people were sitting in a circle facing center.
 A was sitting fourth to the left of B

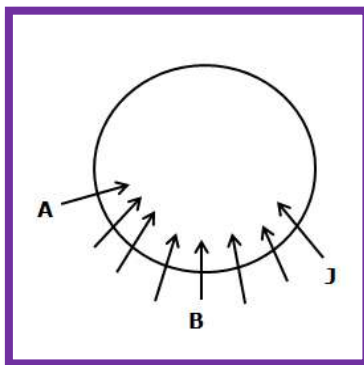
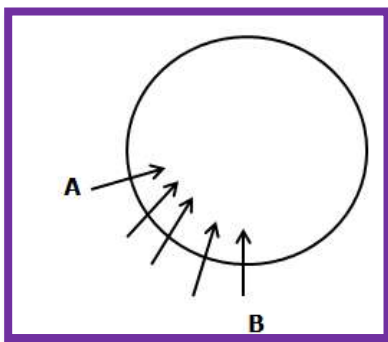

J was sitting seventh to the right of A.

Number of persons sitting between A and B was same as the number of persons sitting between A and F.
 J was the neighbor of D who sits at the seventh position from F (either left or right of F).

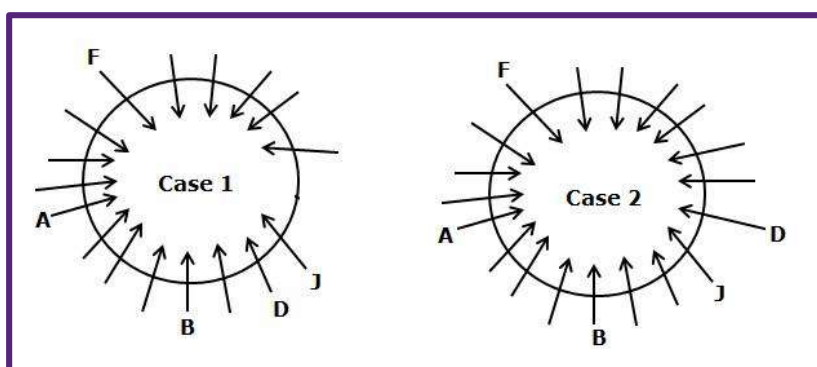

Number of persons sitting between F and M was same as the number of persons sitting between M and D

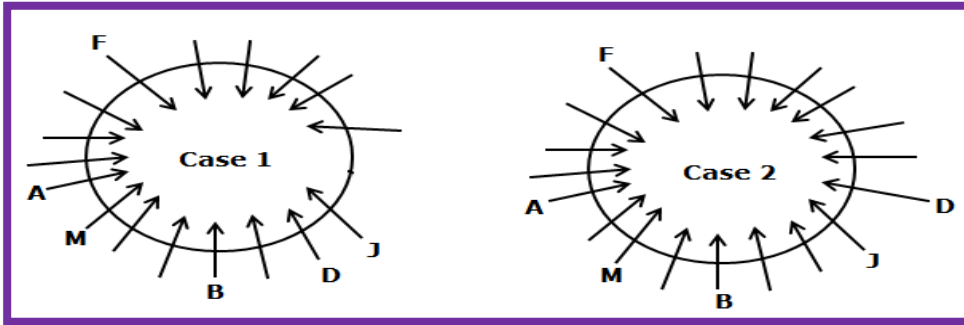

K was the neighbor of J.

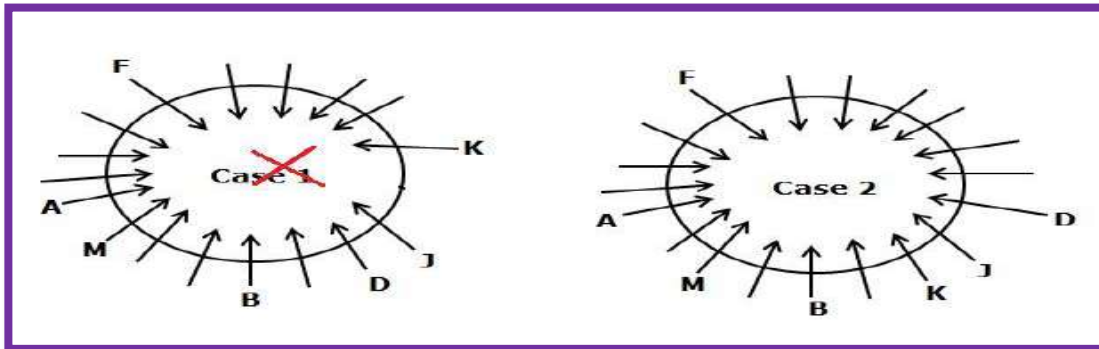
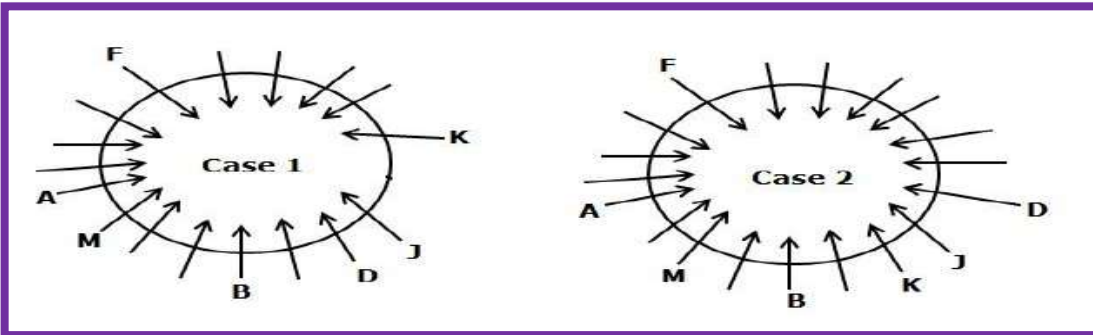

Misnot the immediate neighbor of A. From this statement case 1 is eliminated because M and A are immediate neighbors.

Question 15

Direction (27.1 to 27.5) twelve persons A, B, C, D, E, F, P, Q, R, S, T and U are sitting in two parallel rows with equidistance from each other. In Row-1, A, B, C, D, E and F are sitting and all of them are facing south and in Row-2, P, Q, R, S, T and U are sitting and all of them are facing north but not necessary in the same order.

E sits second to the left of the one who faces P and either one of them sits at the extreme ends of the rows. Two persons are sitting between P and Q. F faces one of the immediate neighbour of Q. U faces the person the one who sits to the immediate right of A. Two persons are sitting between U and S. As many persons sitting to the right of T is same as the number of persons sitting to the right of C and neither of them sits at the extreme ends of the rows. R is not an immediate neighbour of S. C does not face Q. B sits one of the places to the left of E.

15.1 Who sits diagonally opposite to S?

- (a) B (b) A
(c) D (d) F

Answer: C**15.2 How many persons are sitting between T and P the one who faces D?**

- (a) None (b) One
(c) Two (d) Three

Answer: D**15.3 Four of the following five are alike in a certain way and hence form a group. Which one of the following that does not belong to the group?**

- (a) Q (b) P
(c) D (d) S

Answer: A**15.4 Which of the following statements is true?**

- (a) Only two persons are sitting to the right of A (b) U faces E
(c) Q sits exactly between T and R (d) C sits at one of the extreme ends of the row

Answer: B**15.5****If R is related to A and F is related to U in a certain way. Then, Q is related to which of the following?**

- (a) C (b) R
(c) E (d) B

Answer: D**Explanation:**

E sits second to the left of the one who faces P and either one of them sits at the extreme ends of the rows. Two persons are sitting between P and Q. F faces one of the immediate neighbors of Q.

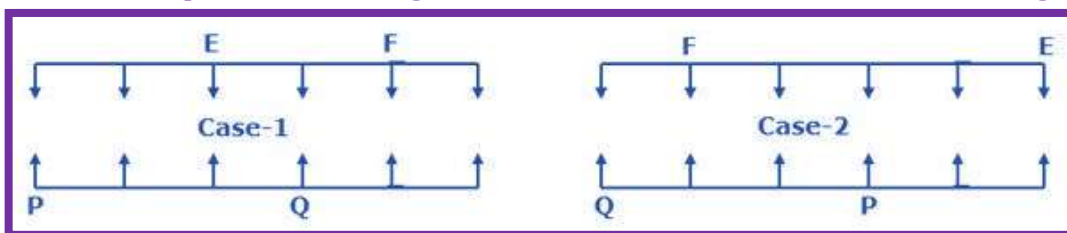

U faces the person the one who sits to the immediate right of A. Two persons are sitting between U and S.

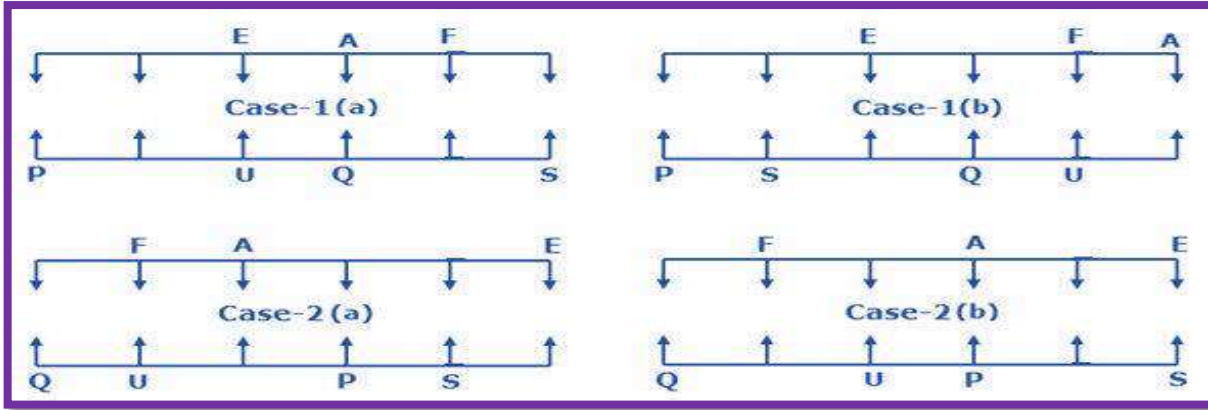

As many persons sitting to the right of T is same as the number of persons sitting to the right of C and neither of them sits at the extreme ends of the rows. R is not an immediate neighbor of S. C does not face Q.

So, Case-1(b), Case-2(a) and Case-2(b) will be dropped.

B sits one of the places to the

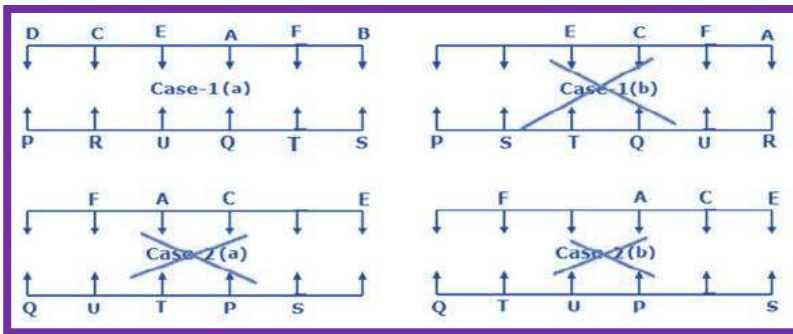

Question 16

Direction (28.1 to 28.5): Read the following information carefully and answer the questions given below. Eight persons P, Q, R, S, T, U, V and W are sitting in a square table such that four of them are sitting at the corners and remaining are sitting at the middle of each side. The persons who are sitting at the corners are facing towards centre of the table and the persons who are sitting at the middle of the sides are facing away from the centre of the table. R sits third to the left of T, who does not sit at one of the middle side of the table. Only one person sits between R and P (Either from right or left). Q sits second to the left of U and not an immediate neighbour of R. W sits opposite to S, who is not an immediate neighbour of P. More than one persons sit between W and R (Either from left or right)

16.1 Who among the following persons sits third to the right of the one who sits to the immediate left of Q?

- (a) S
- (b) R
- (c) Q
- (d) P

Answer: B

16.2 How many persons are sitting between P and T, when counted from left of T?

- (a) Two
- (b) One

(c) Four

(d) Three

Answer: C

16.3 b four of the following five are alike in a certain way and hence form a group. Which one of the following that does not belong to the group?

(a) V

(b) P

(c) U

(d) R

Answer: A

16.4

If R is related to Q and U is related to P in a certain way. Then, V is related to which of the following?

(a) W

(b) S

(c) R

(d) T

Answer: D

16.5 Which of the following statements is true?

(a) U sits second to the right of R

(b) V sits at one of the corners

(c) P sits opposite to T

(d) W faces outside from the center

Answer: B

Explanation:

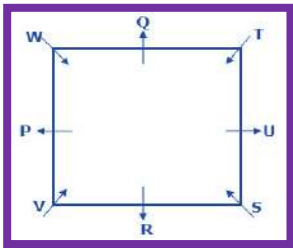

R sits third to the left of T, who does not sit at one of the middle of the sides. Only one person sits

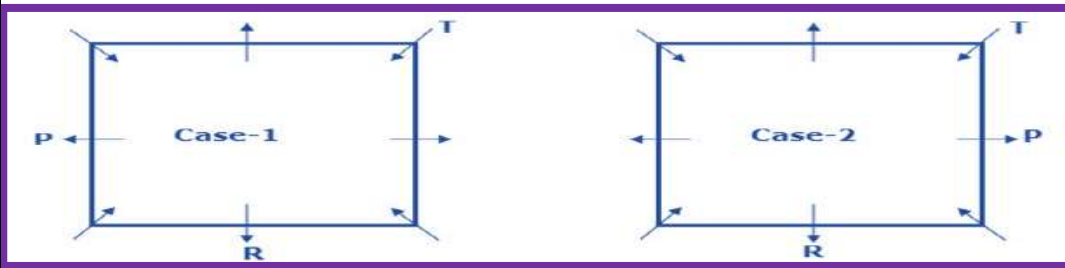

between R and P (Either from right or left).

Q sits second to the left of U and not an immediate neighbour of R.

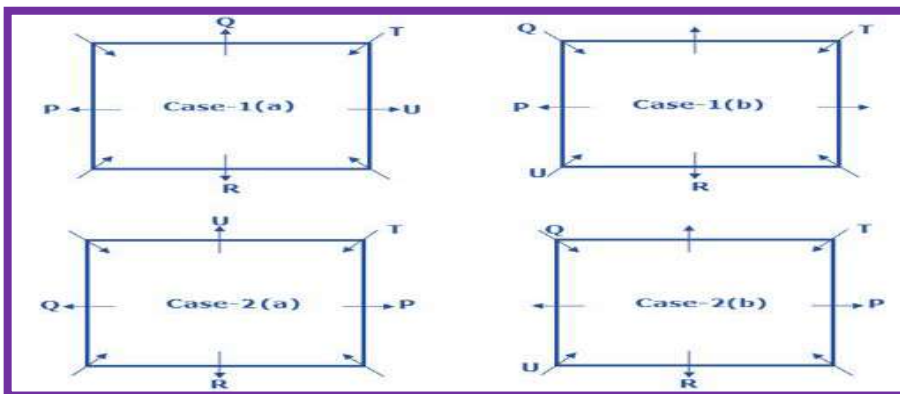

W sits opposite to S, who is not an immediate neighbour of P.
More than one persons sit between W and R (Either from left or right). So, Case-1(b), Case-2(a) and Case-2(b) will be dropped.

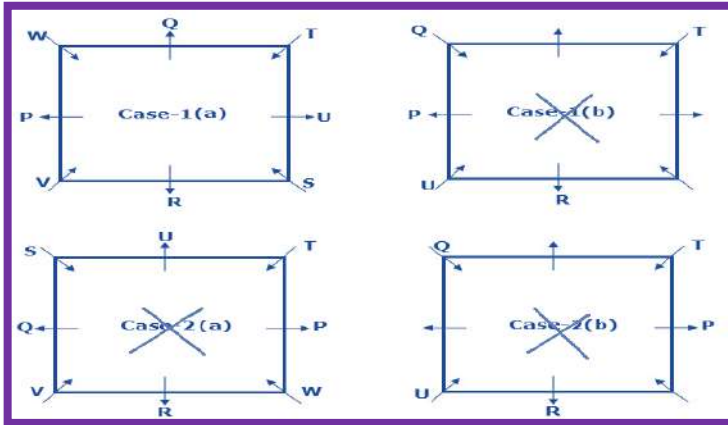

Question 17

Direction (21-25): Read the following information carefully and answer the questions given below.

A certain number of people sitting in the linear row facing north. Only three people sit between A and R. Only four people sit between K and W. Only five people sit between R and K. T sits third to the right of W. Only six people sit between R and Y. Not more than three people sit between K and Y. More than four people are between T and Y. Q sits third to the right of Y. None of them sits between Q and W. J sits eighth to the left of K. Not more than three persons sit between A and J.

17.1 How many people are sitting in the linear row?

- (a) Nineteen
(b) Twenty
(c) Twenty One
(d) Twenty Two

Answer: A

17.2 How many people sits between A and J?

- (a) Seven
(b) Three
(c) Ten
(d) One

Answer: D

17.3 If three people sits between W and H, then which of the following statement is definitely true?

- (a) Three people sit between T and H
(b) W sits fourth to the right of H.
(c) More than six people sit between Q and H.
(d) More than five people sit between Y and H.

Answer: D

17.4 How many people sits between Y and W?

- (a) Sixteen
(b) Three
(c) Ten
(d) Eight

Answer: B

17.5 How many people sit to the left of K?

- (a) Ten
- (c) Sixteen

- (b) Eight
- (d) Thirteen

Answer: A

Explanation:

i). Only three people sit between A and R.

ii). Only six people sit between R and Y.

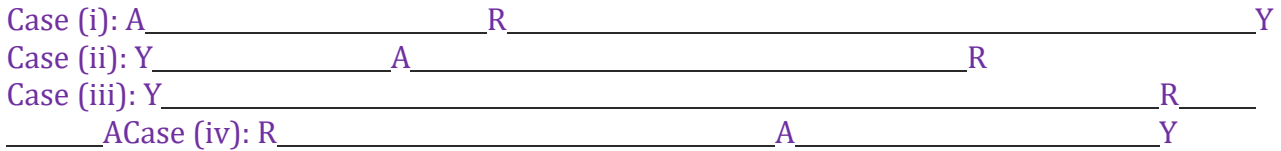

iii). Only five people sit between R and K. iv). Only four people sit between K and W. v). T sits third to the right of W.

vi). Not more than three people sit between K and Y

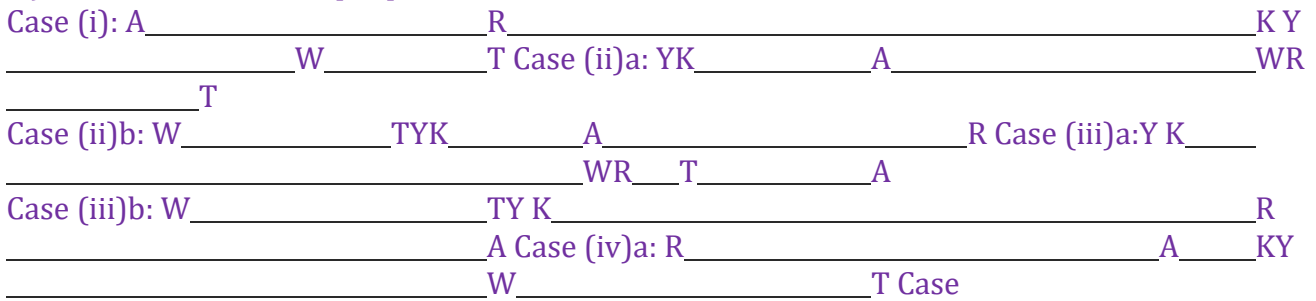

(iv)b: RW _____ A _____ K Y does not follow condition

(v) vii). More than four people are between T and Y.

viii). Q sits third to the right of Y. ix). None of them sits between Q and W.

x). Not more than three persons sit between A and J. xi). J sits eighth to the left of K.

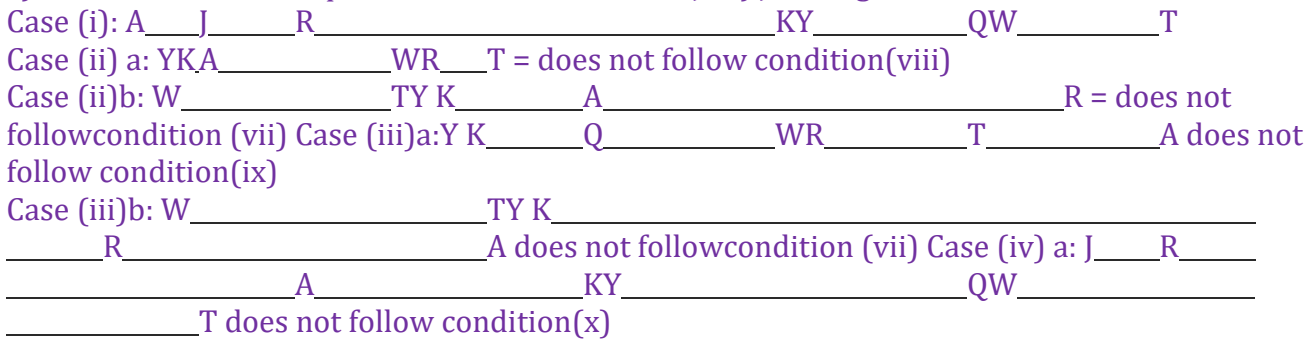

Question 18

Direction (30.1 to 30.5): Study following information carefully and answer the questions given below.

Seven friends- S, T, U, V, W, X and Y are sitting in a straight line. Some of them facing north and some of them are facing south.

Y faces north. Only two persons sit to the left of V. S sits second to the left of W. Only one person sits between S and

U. X sits third to the left of U. The immediate neighbours of S face the opposite directions. T is not an immediate neighbour of W. The immediate neighbours of U face same the

directions. Only two persons sit between V and W. S faces the same direction as U. W sits to the immediate left of Y.

18.1 How many persons sit between Y and T?

- (a) One (b) Two
(c) Three (d) None of these

Answer: D

18.2 Four of the following five are alike in certain way and thus form a group as per the given arrangement. Which of the following does not belong to that group?

- (a) X (b) T
(c) W (d) Y

Answer: A

18.3 What is the position of V with respect to T?

- (a) Second to the left (b) Fourth to the right
(c) Immediate left (d) Second to the right

Answer: D

18.4 How many persons face south directions?

- a) Two b) Three
c) Four d) Five

Answer: B

18.5 Which of the following statement is incorrect?

- (a) W sits at the extreme ends of the line (b) T faces south and sits to the immediate right of U
(c) Only three person sits between Y and the one who sits second to the right of T (d) W faces north and sits second to the right of the one who sits immediate left of T

Answer: C

Explanation:

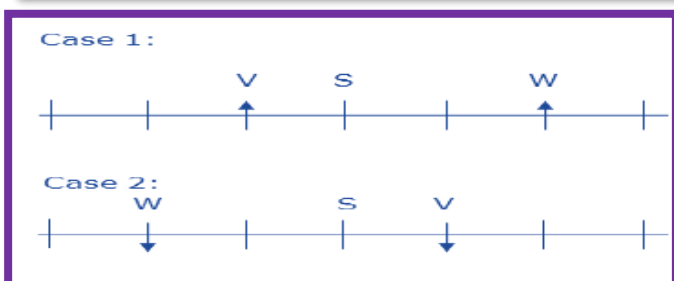

Only two persons sit to the left of V.

Only two persons sit between V and W.

S sits second to the left of W.

Now we have 2 Cases.

The immediate neighbors of S face the opposite directions.

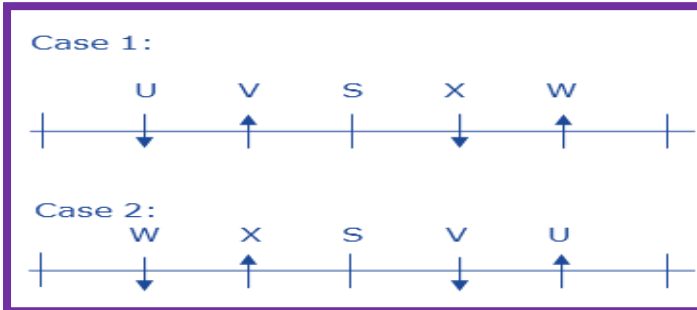
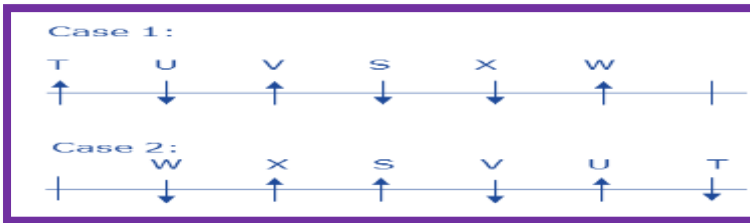

Only one person sits between S and U.
 X sits third to the left of U
 T is not an immediate neighbour of W.
 The immediate neighbor of U faces same the directions.
 S faces the same direction as U
 W sits to the immediate left of Y.
 Y faces north.
 From the above condition Case 2 was dropped.
 So the final arrangement is:

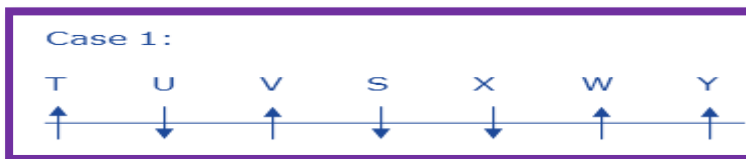

Question 19

Direction (31.1 to 31.5): Read the following information carefully and answer the questions given below.

Eight persons are sitting in a circular table and all of them are facing away from the center of the table. V sits third to the right of M. Only one person sits between V and N (Either from right or left from V). K sits second to the left of G, who is not an immediate neighbour of M. As many persons are sitting between N and S is same as the number of persons sitting between R and S. T sits to the immediate right of R. T does not sit opposite to K.

19.1 Who among the following sits second to the right of S?

- (a) R
- (b) T
- (c) N
- (d) G

Answer: A

19.2 How many persons are sitting between G and V, when counted from left of G?

- (a) Three
- (b) Four
- (c) One
- (d) Two

Answer: D

19.3 Who among the following sits opposite to T?

- (a) V
- (b) S
- (c) K
- (d) G

Answer: D

19.4 Four of the following five are alike in a certain way and hence form a group. Which one of the following that does not belong to the group?

- (a) TG
- (b) KM
- (c) MN
- (d) VS

Answer: C

19.5 If all the persons in the final arrangement are made to sit in the alphabetical order as in the English alphabetical series from G in

clockwise direction, then how many of them remain in their original position (Excluding G)?

- (a) None
- (b) One
- (c) Two
- (d) Three

Answer: B

Explanation:

V sits third to the right of M. Only one person sits between V and N (Either from right or left from V). K sits second to the left of G, who is not an immediate neighbour of M.

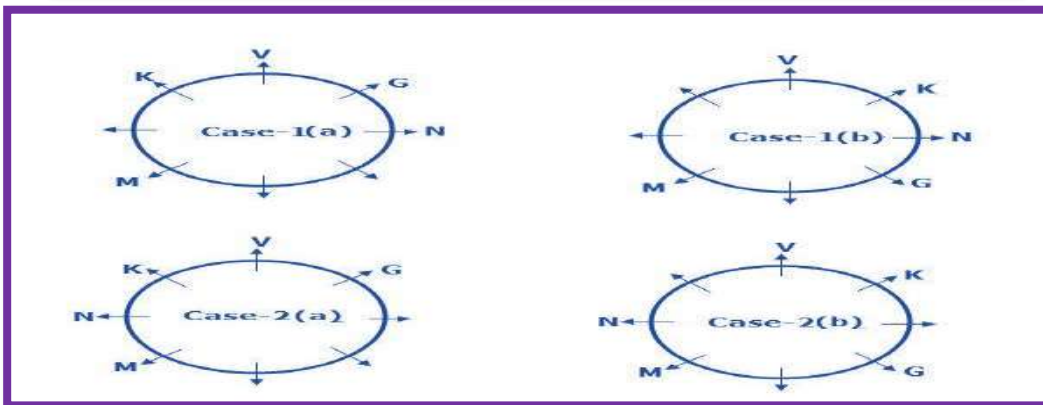
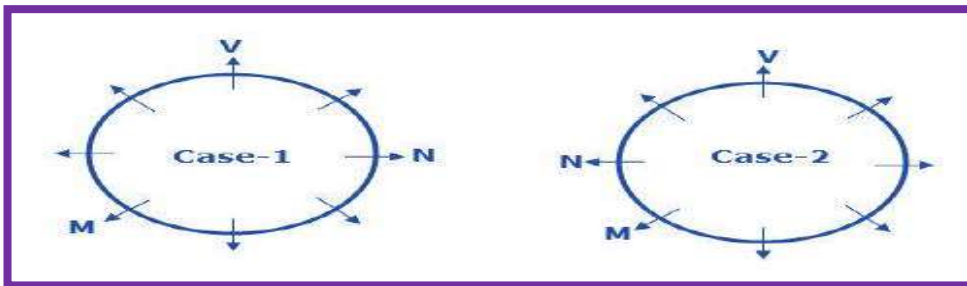

As many persons are sitting between N and S as the number of persons sitting between R and

S. T sits to the immediate right of R.

So, Case-1(a) and Case-2(b) will be dropped.

T does not sit opposite to K.

So, Case-2(a) will be dropped

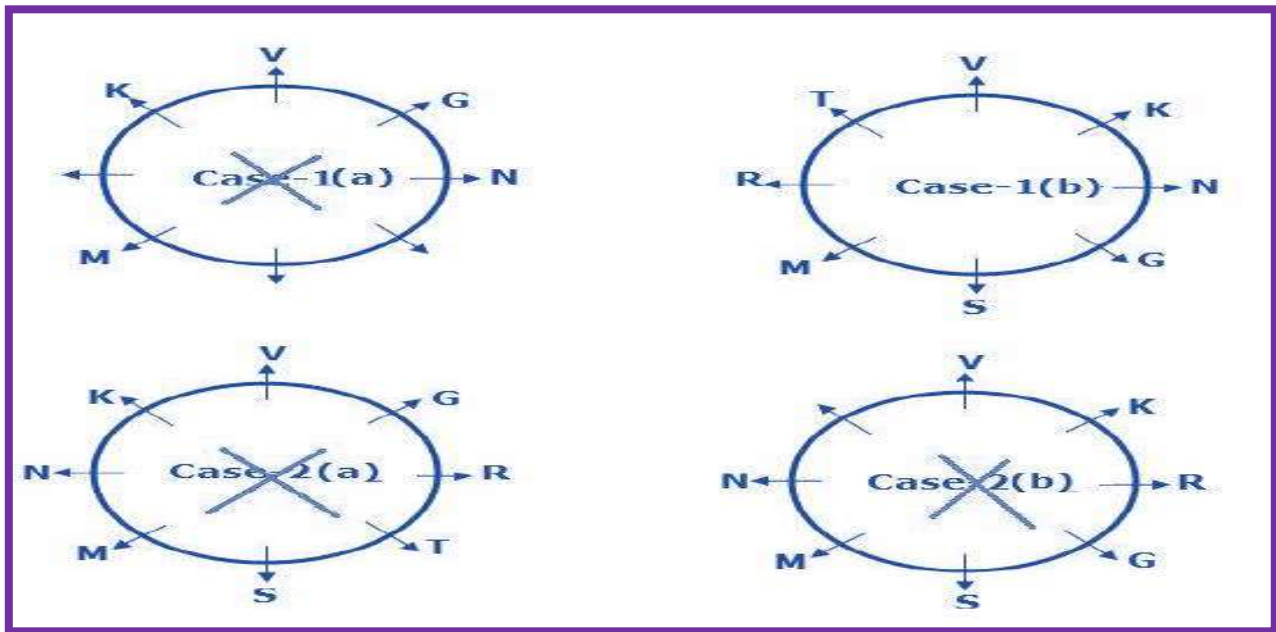

Question 20

Direction (32.1 to 32.5): study the given information carefully and the answer the following question below.

Ten persons are sitting in a parallel row. In Row 1 A, B, C, D and E are sitting in Row 1 facing north. In Row 2 P, Q, R, S and T are sitting in Row 2 facing south. The person in row 1 exactly faces the person in row 2.

R doesn't sit opposite to C. A sits second from the extreme end. Only one person sits between one who faces A and Q. B is not an immediate neighbour of A and doesn't sit opposite to Q. E sits second to the left of B. T doesn't face E and never sits at extreme ends. S is not an immediate neighbor of T. C doesn't sit opposite to Q.

20.1

Four of the five among the following are similar in the arrangement to form a group, which one of the following doesn't belong to the group?

- | | |
|--------|--------|
| (a) CA | (b) ED |
| (c) SQ | (d) BD |

Answer: D

20.2 What is the position of A with respect to B?

- | | |
|------------------------|------------------------|
| (a) Third to the left | (b) Third to the right |
| (c) Second to the left | (d) Immediate left |

Answer: A

20.3 Which of the following statements is not true?

- | | |
|---|---|
| (a) A sits to the immediate left of E | (b) The one who sits opposite to D sits second to the left of T |
| (c) C and B don't sit at the extreme ends | (d) Q is the immediate neighbor of R and S |

Answer: C

20.4 Who sits second to the right of R?

- (a) The one who sits opposite to A
- (b) S
- (c) P
- (d) None of these

Answer: C

20.5 How many person sits between D and B?

- (a) One
- (b) Two
- (c) Three
- (d) None

Answer: D

Explanation:

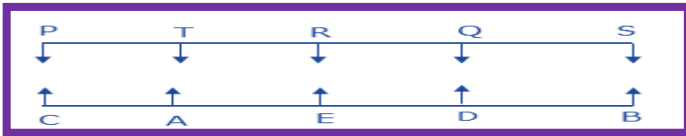

A sits second from the extreme end.



Only one person sits between one who faces A and Q.
B is not an immediate neighbour of A and doesn't sit opposite to Q.



E sits second to the left of B.

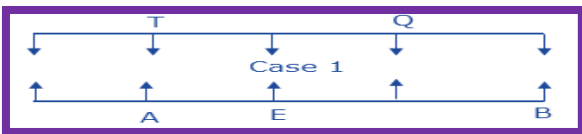
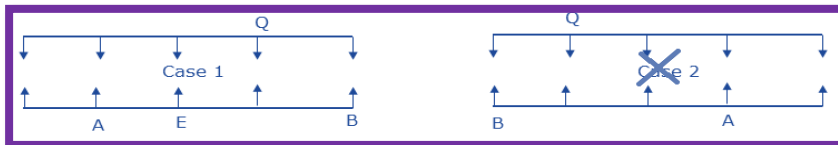

T doesn't face E and never sits at extreme ends.

S is not an immediate neighbour of T.

C doesn't sit opposite to Q.

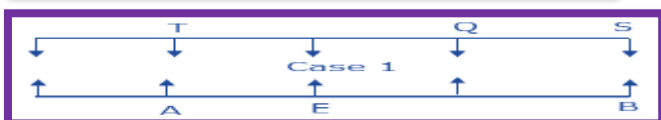
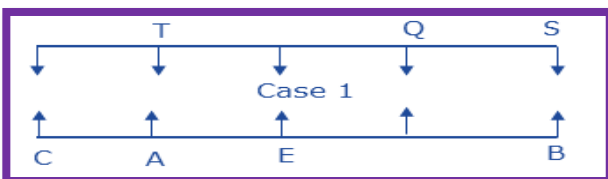

R doesn't sit opposite to C.

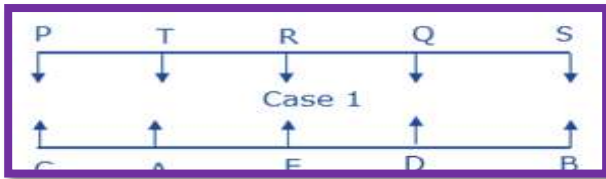

Question 21

Direction (33.1 to 33.5): Study following information carefully and answer the questions given below.

Eight friends – Sundar, Satya, Mark, Cook, Putin, Obama, Trump and Nitish are sitting around the circular table facing center, but not necessarily in the same order. Putin and Obama are not immediate neighbours. Only two persons sit between Sundar and Trump. Obama is not an immediate neighbour of Trump and Cook. Putin is not an immediate neighbour of Mark and Trump. Sundar sits second to the left of Cook. Nitish is not an immediate neighbour of Putin. Only three persons sit between Mark and Obama. Satya sits not opposite of Cook. Trump is not an immediate neighbour of Putin.

21.1 What is the position of Cook with respect to Putin?

- | | |
|------------------------|-------------------------|
| (a) Third to the right | (b) Second to the right |
| (c) Immediate right | (d) Fourth to the right |

Answer: C

21.2 How many persons sit between the one who sits the second to the left of cook and Mark, when counted from left of Mark?

- | | |
|-----------|------------|
| (a) One | (b) Two |
| (c) Three | (d) No one |

Answer: B

21.3 Which of the following statement is incorrect?

- | | |
|--|--|
| (a) Cook sits to the immediate left of Trump | (b) Only three persons sit between Satya and Sundar |
| (c) Sundar and Mark is an immediate neighbours | (d) Only one person sits between Nitish and the one who sits to the immediate left to Sundar |

Answer: C

21.4 What is the position of the one who sits second to the left of Sundar with respect to Trump?

- | | |
|-------------------------|-------------------------|
| (a) Immediate right | (b) Fourth to the right |
| (c) Second to the right | (d) Second to the right |

Answer: A

21.5 Which of the following statement is correct?

- | | |
|--|---|
| (a) Nitish sits to the immediate left of Obama | (b) Cook is an immediate neighbour of Satya |
|--|---|

(c) Only two persons sit between Mark and Nitish when counted from left of Nitish

(d) Both a and c

Answer: D

Explanation:



Only two persons sit between Sundar and Trump.
Sundar sits second to the left of Cook.
Now we have 2 cases

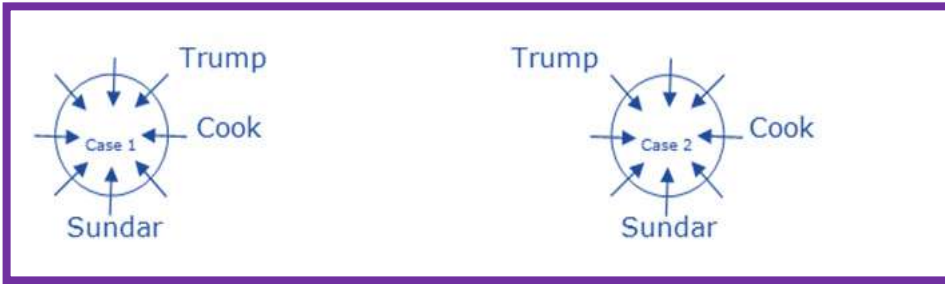

Obama is not an immediate neighbour of Trump and Cook.
Only three persons sit between Mark and Obama

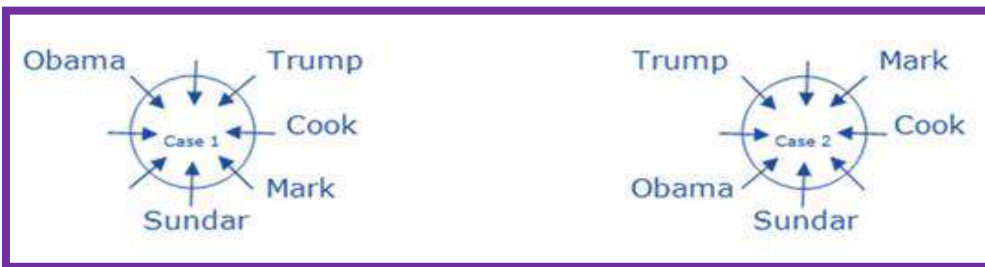

Putin is not an immediate neighbour of Mark and Trump.
Satya sits not opposite of Cook.
Putin and Obama are not immediate neighbours.
Nitish is not an immediate neighbour of Putin. Trump is not an immediate neighbour of Putin.
From the above condition Case 1 was dropped.
So the final arrangement is..



Question 22

Direction (34.1 to 34.5): Read the following information carefully and answer the questions given below.

Eight people I, J, K, L, M, N, O and P are sitting in a rectangular table. Only three persons are sitting in the longer side of the rectangle. The people sits at longer side of table faces outside the table, while the people sits at smaller side of the table faces inside the table. All the information is not necessary to be in the same order.

N sits second to the left of M. Only two persons sit between M and P, who is not an immediate neighbour of N. J sits immediate right of L. P sits opposite to I. Neither K nor L is an immediate neighbour of P. J sits second to the right of O and both are facing same direction. J does not sit opposite to O.

22.1 Name the person who sits opposite to J?

- (a) M
- (b) O
- (c) N
- (d) I

Answer:C

22.2 Who sits second to the left of P?

- (a) L
- (b) K
- (c) J
- (d) O

Answer:B

22.3 If all the people are made to sit in alphabetical order in clock wise direction from I, then how many of them remains in their original position?

- (a) One
- (b) Two
- (c) Three
- (d) More than Three

Answer:A

22.4 Name the person who sits second to the right of L?

- (a) L
- (b) K
- (c) J
- (d) None of these

Answer:D

Who sits fourth to the left of J?

- (a) L
- (b) M
- (c) J
- (d) O

Answer: B

Explanation:

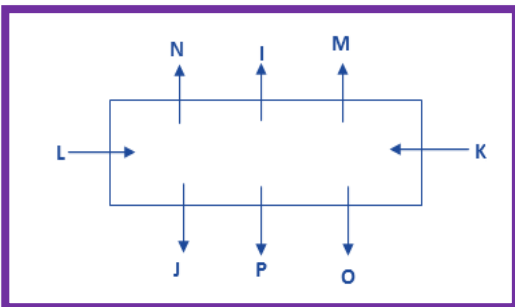

N sits second to the left of M.

Only two persons sit between M and P, who is not an immediate neighbour of N. iii). P sits opposite to L.
 Neither K nor L is an immediate neighbour of P.
 J sits second to the right of O and both are facing same direction.
 J does not sit opposite to O.
 J sits immediate right of L.

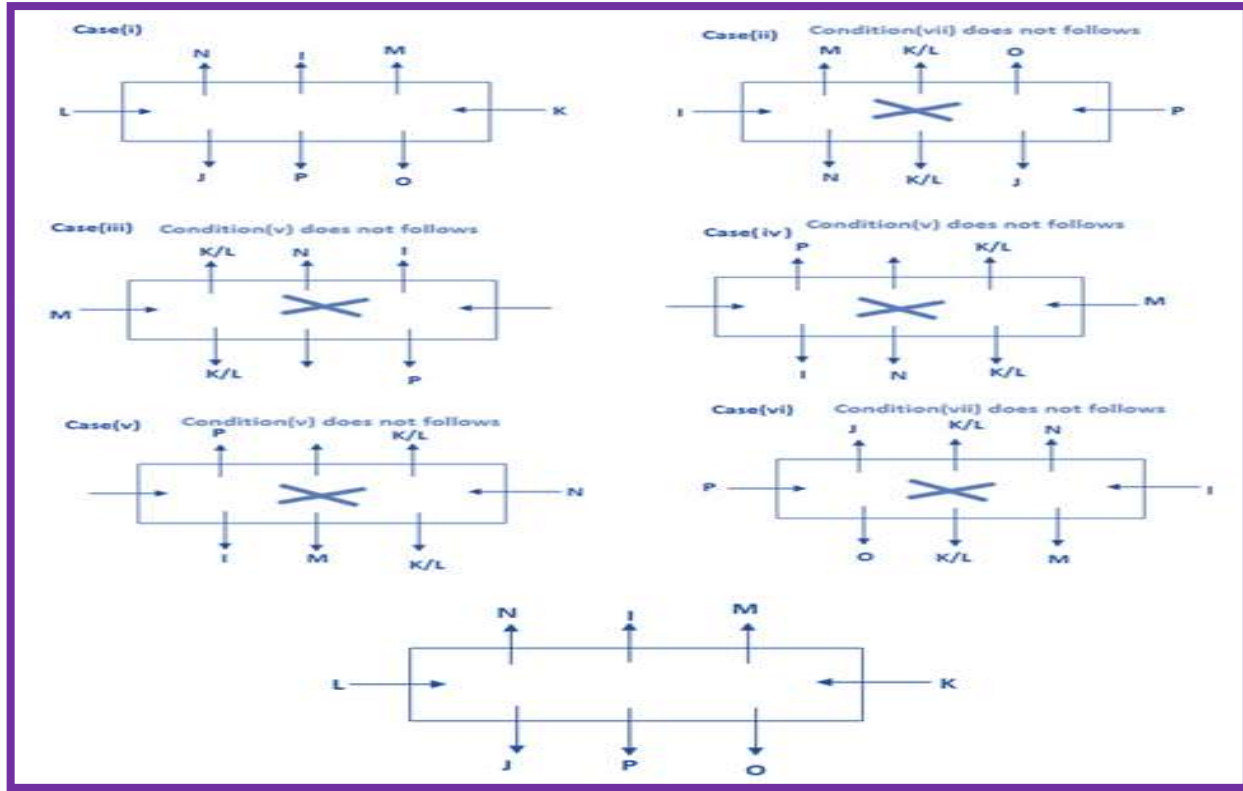

Question 23

Direction (35.1 to 35.5): Study the following information carefully to answer the given questions.

Six Students- Sita, Smita, Sunita, Sarita, Sujitha and Sneha lives on a building which has Six Floors with top floor numbered as 6. They got different Ranks from 1 to 6 in a School exam. They are also having different Lucky numbers from 1 to 6. These Six Students are also sitting in a row which has six seats and all are facing north. All students are having unique floor number, Lucky number, and Rank (i.e., No two numbers will be same for a particular student).

Students who sit at extreme ends of the row live neither on the top floor nor on the bottom floor. Sujitha lives on an even numbered floor. Sarita Floor number and Sita Lucky number are same. Two students live between Sita and Smita. Smita sits third to the left of Sujitha. One who lives on top floor sits third to the left of Sneha. A student whose Lucky number is 3 sits third to the right of the student whose lucky number is 5. Sita's Rank is 5. Two students live between Sujitha and Sarita. Smita Lucky number is same as Sita Floor number. Sunita Rank is 6 and she lives on an even numbered floor. Sneha's Rank is same as Sita's Lucky number. Sneha sits second to the right of Smita. Sneha's Lucky number is same as Sarita's Rank. Sujitha Rank is same as Sarita Lucky number.

23.1 Which of the following Pair is sitting at extreme ends?

- (a) Sita and Sneha
(b) Sunita and Sarita
(c) Sujitha and Smita
(d) Sunita and Sujitha

Answer: D

23.2 Who among the following is living on Bottom Floor?

- (a) Sarita
(b) Smita
(c) Sneha
(d) Sita

Answer: A

23.3 What is the Lucky number of Sita?

- (a) One
(b) Two
(c) Three
(d) Four

Answer: A

23.4 Who among the following got Rank 2?

- (a) Sita
(b) Sneha
(c) Smita
(d) Sujitha

Answer: C

23.5 Which of the following statement is false?

- (a) Sita lives on top floor
(b) Sneha's Rank is 1
(c) Sujitha Lucky number is 2
(d) Sarita Rank is 3

Answer: D

Explanation-

Floor No	Rank	Lucky No	Person
6	5	1	Sita
5	1	4	Sneha
4	3	2	Sujitha
3	2	6	Smita
2	6	5	Sunita
1	4	3	Sarita



Question 24

Direction (36.1 to 36.5): Eight persons – A, B, C, D, E, F, G, and H are sitting in two rows having five seats in each row. In each row, one seat is vacant. Some of them are facing north and some are facing south.

Two persons are sitting between D and B. C sits opposite to D. G sits opposite to E. H sits

opposite to the person who is sitting second to the left of F. F is not adjacent to E. Vacant seats are not opposite to each other. A, C and G face the same direction (i.e., All face either North or South). D, B, and E face the same direction (i.e., All face either North or South). C sits second to the right of E. H faces north. C doesn't sit at the extreme end. E sits second to the right of C. E sits to the adjacent left of H.

24.1 How many persons are sitting between A and H?

- (a) One (b) Two
(c) Three (d) Four

Answer: B

24.2 Who among the following pair is sitting opposite to vacant seats?

- (a) A and D (b) B and A
(c) C and F (d) A and F

Answer: D

24.3 Who among the following is facing South?

- (a) A (b) B
(c) F (d) G

Answer: C

24.4 Which of the following pair is sitting in the same row?

- (a) A and D (b) C and F
(c) E and B (d) B and F

Answer: D

24.5 Which of the following statement is false based on above arrangement?

- (a) A faces North (b) B sits at one of the extreme ends
(c) D sits third to the right of B (d) Both the vacant seats are at extreme ends

Answer: D

Explanation:

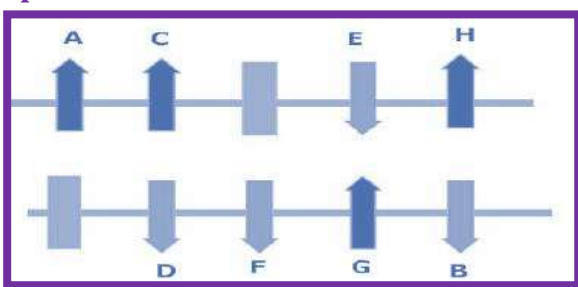

Question 25

Study the following information carefully to answer the given questions.

Eight members P, Q, R, S, T, U, V and W of a family are sitting around a rectangular table with all of them facing outwards. Each one of them like different type of music instruments viz. XYLOPHONE, Balafon, Guitar, Piano, VIOLIN, TRUMPET, Accordions and Flute. Three married couples are there in the family.

W is the only sister-in-law of P whereas Q likes TRUMPET and daughter-in-law of RP who is the father of U and uncle of V, sits to the left of the person who likes XYLOPHONE. U is an immediate neighbor of her aunty W who does not sit next to S. R does not like Flute or

Accordion. The two youngest members sit next to each other. The one who likes the Balafon sits between V and the one who likes VIOLIN. V is third to the left of S. The one who likes TRUMPET sits between the persons who like Accordion and Flute Respectively. S's husband and son sit next to her. Piano is not liked by V's father. V does not like Guitar or Accordion. S is the mother of P and T, and sits second to the left of T.

25.1 Which of the following statements is true regarding the family?

- (a) P is the brother of W
- (b) R is the father-in-law of P
- (c) Q is the aunty of V
- (d) U and V are married couple

Answer: C

25.2 Who among the following sits between Q and the one who likes Balafon?

- (a) P
- (b) T
- (c) S
- (d) V

Answer: D

25.3 What is the position of the person who likes Piano with respect to the one who likes TRUMPET?

- (a) Third to the right
- (b) Second to the left
- (c) Immediate left
- (d) Third to the left

Answer: D

25.4 Who among the following likes Guitar?

- (a) W
- (b) U
- (c) V
- (d) T

Answer: D

25.5 Which of the following options represent a pair?

- (a) Y, X
- (b) W, T
- (c) W, R
- (d) S, U

Answer: B

Explanation-

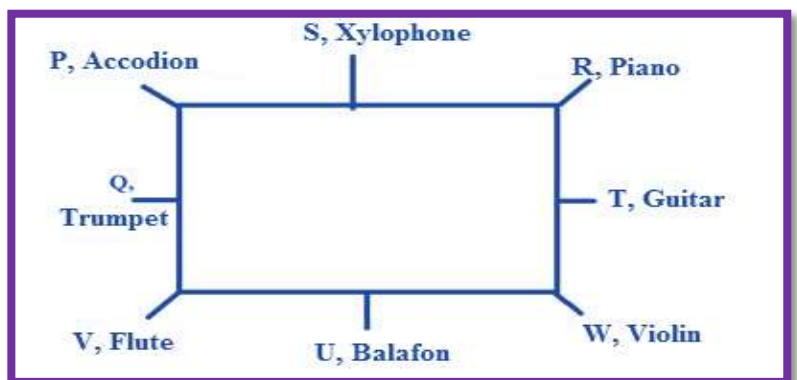
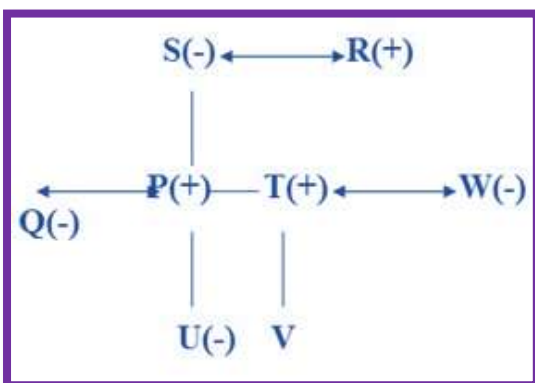

Question 26

Study the following information carefully to answer the given questions.

Eight players - P, Q, R, S, T, U, V and W sit around a square table in such a way that four of them sit on the four sides while the rest at corners. They play different instruments

namely Xylophone, Balafon, Guitar, Piano, Violin, Trumpet, Accordion and Flute. Some of them are facing the centre while some are facing outside. (i.e away from the centre)

Note: Same directions means that if one person facing the centre then the other person also faces the centre and vice versa. Opposite direction means if one person is facing the centre then the other person faces outside and vice versa.

Q faces the centre of the table and does not sit on any corner. V sits on one of the corner between the Flute player and Trumpet player. W sits second to the right of Balafon player who faces the centre.

The Violin player sits third to the left of Q. S sits opposite to W. P sits on the corner exactly opposite to T. The Balafon player sits third to the right of Accordion player. The Xylophone player does not facing the centre.

The Trumpet sits opposite to Q, also faces in opposite direction of Q and sits between Accordion player and Violin player. T who is the Violin player sits immediate right to the Piano player.

The Piano player faces the same direction of the U. The immediate neighbours of Q are facing opposite directions. The Accordion player sits exactly opposite to Guitar player. The one who is on the immediate left of U is facing the same direction as W. R sits third to the left of W.

26.1 Who among the following is a Trumpet player?

- (a) P (b) U
(c) T (d) Can't be determined

Answer: B

26.2 R is related to which of the following Instruments?

- (a) Guitar (b) Xylophone
(c) Accordion (d) Can't be determined

Answer: A

26.3 Who among the following sits exactly between R and the Xylophone Player?

- (a) The person who plays Flute (b) The person who plays Accordion
(c) The person who plays Balafon (d) Trumpet

Answer: C

26.4 How many persons sit facing the centre?

- (a) None (b) One
(c) Two (d) Four

Answer: D

26.5 Which of the following pairs are the immediate neighbors of the Flute player?

- (a) P, V (b) P, R
(c) V, R (d) Q, R

Answer: A

Explanation-

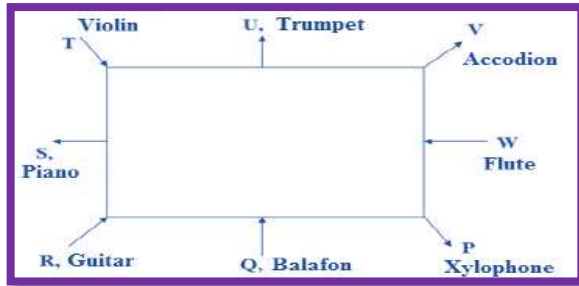

Question 27

Study the following information carefully to answer the given questions.

There are 16 persons – B,C,D,E,F,G,H,I,P,Q,R,S,T,U,V and W standing in a square plot. Inside a Square plot, a square shaped garden is developed. The persons who are standing inside the garden facing outside. The persons who are standing outside the garden facing inside the centre and likes colours namely viz., – Red, Blue, Black, Brown, Yellow, Green, Violate and Pink. So all the persons standing in the inner square faces the persons standing in the outer Square and likes fruits namely viz., – Apple, Orange, Mango, Grapes, Papaya, Pomegranate, Guava and Banana.

G faces the centre and W faces G. D sits second to the right of G. There are four persons sits between G and E. D is not an immediate neighbour of E. There are three persons standing between I and E. There are two persons standing between I and B. B stands exactly between the E and F. F stands to the immediate left of G. There are two persons standing between W and U. U faces H. T faces outside. There are two persons standing between T and Q. T faces C. Q stands to the immediate left of W. R, the one who faces B stands exactly between the persons P and V. P faces E. The one who sits in the corner of the square likes Red. The one who likes Red sits between the persons who like Black and Blue. The one who likes Blue sits second to the right of the person who likes Green. Three persons sit between one who likes Black and one who likes Green. Two persons sit between one who likes Black and one who likes Yellow. Two persons sit between one who likes Yellow and one who likes Pink. G and F do not like Violate and Yellow respectively. The one who likes Red faces P. The immediate neighbours of P are the one who likes apple and the one who likes Grapes. The one who likes Apple faces the one who likes Black. Three persons sit between the one who likes apple and the one who likes Guava. The immediate neighbours of the person who likes Orange are the one who likes apple and the one who likes Pomegranate. The one who likes Papaya sits exactly behind to the one who likes Orange. The one who likes Banana sits exactly behind to the one who likes Mango. The one who likes Banana faces E.

27.1 In the given arrangement, if three people come and stand to the immediate left of E, how many people will sit between F (From the left of F) and C?

- | | |
|----------|--------------------|
| (a) Two | (b) Three |
| (c) Five | (d) More than four |

Answer: C

27.2 Who amongst the following likes Green?

- | | |
|---------------------------------------|-------|
| (a) C | (b) B |
| (c) Other than those given as options | (d) D |

Answer:D

27.3 How many people stand between V and U?

- (a) Two
- (b) Three
- (c) Four
- (d) More than four

Answer: B

27.4 Four of the following five are alike in a certain way based upon their arrangement and so form a group. Which of the following does not belong to the group?

- (a) FV
- (b) UH
- (c) EP
- (d) GW

Answer: D

27.5 Who amongst the following likes Papaya?

- (a) P
- (b) U
- (c) Q
- (d) E

Answer: B

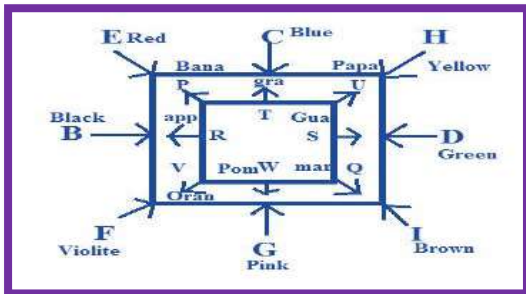

Explanation-

Question 28

Study the following information carefully to answer the given questions.

There are 16 persons – B,C,D,E,F,G,H,I,P,Q,R,S,T,U,V and W standing in a Circular plot. Inside a circular plot, a circularly shaped garden is developed. The persons who are standing inside the garden facing outside. The persons who are standing outside the garden facing inside the centre and lives in a different number of floors. So all the persons standing in the inner circle faces the persons standing in the outer circle and hold a different number of chocolates.

G faces outside and S faces G. D sits immediate right of G. There are four persons sits between G and E. H is not an immediate neighbour of E. There are two persons standing between D and H. H faces R. There are three persons standing between R and U. U stands exactly between the B and F. B faces D. There are two persons standing between P and C. Neither S nor R is an immediate neighbour of P. I stands to the immediate left of H. I faces T. The one who faces F stands exactly between the persons Q and W. W faces P. H stands second to the left of G. B lives on the second floor and sits exactly opposite to the person who lives on the floor which is the square number of the floor of B. F lives on the third floor and stands exactly opposite to the person who lives on the floor which is the square number of the floor of F. P lives on 6th floor and S lives immediately above P. U lives immediately below B. R lives immediately above T. The one who faces P holds chocolates two less than the number of the floor occupied by P. The one who faces U holds chocolates six more than the number of the floor occupied by U. Number of chocolates hold by E is the difference between the number of chocolates hold by D and W. Number of chocolates hold by G is the sum of the number of chocolates hold by D and E also equals to number of

chocolates hold by V and H. Number of chocolates hold by I is the square of the number of chocolates hold by H.

28.1 In the given arrangement, how many people will sit between B and T?

- (a) Five (b) Three
(c) Four (d) More than four

Answer: B

28.2 Who amongst the following lives on the seventh floor?

- (a) S (b) Q
(c) Other than those given as options (d) U

Answer: A

28.3 If persons counted from the right of G, then how many people stand between G and E as per the given arrangement?

- (a) Five (b) Three
(c) Four (d) Two

Answer: D

28.4 Four of the following five are alike in a certain way based upon their seating arrangement and so form a group. Which of the following does not belong to the group?

- (a) F (b) E
(c) C (d) G

Answer: D

28.5 Who amongst the following have seven chocolates?

- (a) T (b) F
(c) Q (d) P

Answer: C

Explanation-

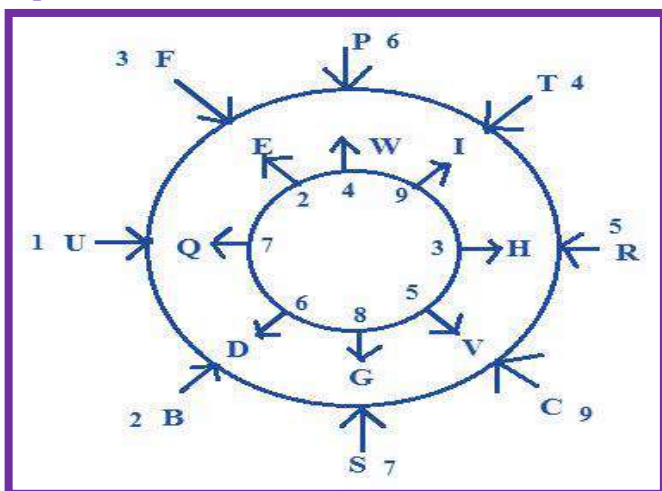

Question 29

Study the following information carefully to answer the given questions.

Ten persons from ten different countries viz. Mumbai, Chennai, Bengaluru, Kolkata, Pune, Hyderabad, Jaipur, Ahmedabad, Surat and Kochi are sitting in two parallel rows containing

five people each, in such a way that there is an equal distance between adjacent persons. In row 1- A, B, C, D and E are seated and some of them are facing South and some of them are facing North. In row 2 - P, Q, R, S and T are seated and some of them are facing South and some of them are facing North. Therefore in the given seating arrangement, each member seated in a row either faces another member of the other row or seated behind each other. (All the information given above does not necessarily represent the order of seating in the final arrangement.). Each person stays in ten different floors numbered 1 to 12. (From Ground floor to Top floor)

There is only one floor between the person from Mumbai and the person from Pune. S is not from Bengaluru. D is neither from Pune nor from Hyderabad. P sits immediate right of the person from Surat. R sits one of the extreme ends of the line and from Surat. C sits third to the right of the person from Chennai. P does not face A and faces south direction. The person from Mumbai sits exactly between the persons from Kochi and Pune. The person from Hyderabad faces the person from Kochi. The person from Surat stays on the odd numbered floor. T faces North Direction and sits immediate left of Q. Only one person sit between the persons from Bengaluru and Kolkatta. The person from Kolkatta sits to the immediate right of Q, who seated exactly in the middle of the row. P faces one of the immediate neighbors of the person from Chennai. D faces one of the immediate neighbors of the person from Bengaluru. The person from Kochi stays on the top floor. Only One person sits between the person from Surat and Q. C sits to the immediate right of the person who faces S. The person from Hyderabad stays on the 4th floor. Only two people sit between C and E. S is neither from Mumbai nor from Ahmedabad. The person from Pune sits second to the right of the one who faces North Direction. One of the immediate neighbors of the person from Pune behind the person from Bengaluru. A faces the opposite direction to the person from Jaipur. The persons from Bengaluru, Jaipur and Kolkata stay on the consecutive floors. The floor number of the person from Chennai is the double of the floor number of the person from Surat. The floor number of the B is the square of the floor number of P. Neither E nor A stays on floor numbered 6.

29.1 Who amongst the following faces the person from Hyderabad?

- | | |
|----------------------------|---------------------------|
| (a) The person from Mumbai | (b) D |
| (c) The person from Pune | (d) The person from Surat |

Answer: B

29.2 T stays on which of the following floors?

- | | |
|-------|-------|
| (a) 1 | (b) 2 |
| (c) 4 | (d) 6 |

Answer: A

29.3 Which of the following is true regarding C?

- | | |
|-----------------------------|---------------------------------------|
| (a) C faces south direction | (b) None of the given options is true |
| (c) C is from Bangladesh | (d) The person from India faces C |

Answer: A

29.4 R is related to Kolkata in the same way as C is related to Pune based on the given arrangement, To who amongst the following is T related to the following same pattern?

- | | |
|---------------|---------------|
| (a) Mumbai | (b) Sri Nagar |
| (c) Bengaluru | (d) Hyderabad |

Answer: D

29.5 Who amongst the following sit at extreme ends of the row?

- (a) The person stays on 8th floor and R
- (b) The persons from Ahmedabad and A
- (c) D and the person stays on 10th floor
- (d) The persons from Hyderabad and Bengaluru

Answer: C

Explanation-

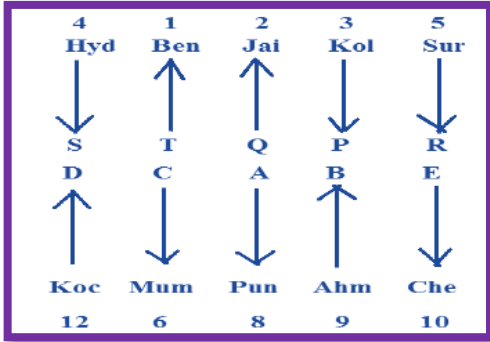

Question 30

Study the following information carefully to answer the given questions.

Ten friends are sitting in two parallel rows of six seats each. One seat is vacant in each row. M, N, O, P and Q are sitting in row-1 facing south. D, E, F, G and H are facing North. Each likes a different Chocolate i.e. 5star, Dairy Milk, Munch, Kitkat, Perk, Snickers, Bourneville, Gems, Eclairs and Galaxy. Each person has different number of their favourite chocolates - 2, 3, 4, 6, 7, 8, 9, 11, 15 and 16.

The difference between the chocolates hold by N and O is 3. G sits third to the right of F and likes Kitkat. Only two people sit between E and the vacant seat. E does not like Perk or Munch Chocolate. Q is not an immediate neighbour of O. N likes Galaxy. The persons who sit at the extreme end of the line have chocolates in consecutive order. Neither E nor H has 8 chocolate. One of the neighbors of vacant seat in both rows have chocolates in odd number. The one who likes Munch Chocolate faces the one who likes Gems. The one who likes Munch sits opposite to the one who sits third right of the person who sits opposite to G. O is not an immediate neighbour of P. H, who likes neither Perk nor Snickers, does not face the vacant seat. Neither G nor F sits at any of the extreme ends of the row. P faces F. Vacant seats are not opposite to each other. Two seats are there between O and N, who sits third right of the one who likes Bourneville. The one who likes Eclairs Chocolate faces the one who likes Kitkat. The persons who like the 5star and Gems are adjacent to each other. Vacant seat of row - 1 is not an immediate neighbour of P. E sits at one of the extreme ends of the row. F does not like 5star and Gems. Vacant seat of row-1 does not face G who doesn't sit at any of the extreme ends of the row. The person who likes 5star has 3 chocolates. The total number of chocolates hold by Q is the half of the total number of chocolates hold by H. The total numbers of chocolates hold by M, F and G is the Square of the total number of chocolates hold by P, Q and M respectively. Neither P nor G has 4 chocolate.

30.1 In the given arrangement, if two people come and sit to the immediate left of E, how many people will sit between D and E?

- (a) Two
- (b) Three
- (c) Four
- (d) More than four

Answer: B

30.2 Who amongst the following sits third to the right of F?

- (a) The one who likes Kitkat
- (b) E
- (c) Other than those given as options
- (d) D

Answer: A

30.3 Which of the following faces the vacant seat of Row - 1?

- (a) The one who likes Kitkat
- (b) E
- (c) Other than those given as options
- (d) The one who has 15 chocolate

Answer: D

30.4 Four of the following five are alike in a certain way based upon their seating arrangement and so form a group. Which of the following does not belong to the group?

- (a) QE
- (b) ND
- (c) HO
- (d) FP

Answer: D

30.5 Who among the following has 11 chocolates?

- (a) Q
- (b) N
- (c) D
- (d) E

Answer: B

Explanation-

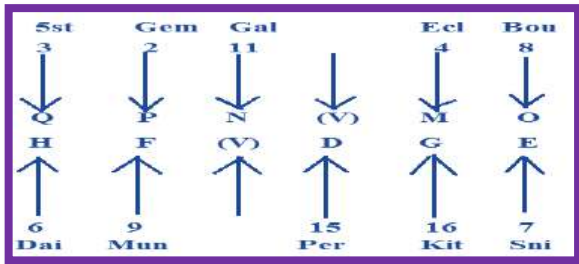

Question 31

Study the following information carefully to answer the given questions.

Eight friends C, D, E, F, L, M, N and O are seated in a straight line, but not necessarily in the same order. Some of them are facing north while some face South. Only three people sit to the right of M. E sits second to the left of M. F sits third to the right of O. O is not an immediate neighbour of M. O does not sit at any of the extreme ends of the line. Both the immediate neighbours of O face south.

D sits second to the right of N. As many people sit between M and D as between M and L. Immediate neighbours of F face opposite directions (i.e., If one person faces north then the other person faces south and vice-versa). C faces south. L and F face direction opposite to C. (i.e If C faces north then both L and F face south and vice-versa)

31.1 Which of the following is true, based on the given arrangement?

- (a) D faces North
- (b) Only three people face South
- (c) L sits at one of the extreme ends of the line
- (d) O and E face the same directions

Answer: D

31.2 How many people sit to the left of O?

- (a) Two (b) Three
(c) One (d) More than four

Answer: C**31.3 Who amongst the following faces South?**

- (a) E (b) M
(c) F (d) L

Answer: B**31.4 Who amongst the following sits second to the left of L?**

- (a) O (b) F
(c) D (d) No one as less than two people sit to the left of L

Answer: B**31.5 Who amongst the following represent the persons sitting at extreme ends of the line?**

- (a) D, N (b) C, D
(c) L, N (d) D, L

Answer: B**Explanation-****Question 32****Study the following information carefully to answer the given questions.**

Eight people B, C, D, E, F, G, H and I are sitting in a straight line with equal distances between each other, but not necessarily in the same order. Some of them are facing north and some of them are facing south.

E sits immediate right of the person who sits at one of the extreme ends of the line. Only three people sit between E and G. B sits exactly between D and H.

C sits third to the right of H. F is an immediate neighbour of G and faces south. G sits second to the right of C. D sits third to the left of G. B and E face the same direction as C (i.e. if C faces north then B and E also face North and Vice-Versa).

Immediate neighbours of G face opposite directions (i.e. if one neighbour faces North then the other neighbour faces south and Vice-Versa)

Person who sit at the extreme ends of the line face opposite directions (i.e. if one neighbour faces North then the other neighbour faces south and Vice-Versa)

D and H face the same direction as I (i.e. if I faces north then D and H also face North and Vice-Versa).

32.1 In the given arrangement, how many people will sit between D and G?

- (a) Two (b) Three
(c) Four (d) More than four

Answer: A**32.2 Who amongst the following sits third to the right of B?**

- (a) E (b) I
(c) Other than those given as options (d) F

Answer: B

32.3 How many people face South as per the given arrangement?

- (a) Two (b) Three
(c) Four (d) More than four

Answer: C

32.4 Four of the following five are alike in a certain way based upon their seating arrangement and so form a group. Which of the following does not belong to the group?

- (a) IH (b) EG
(c) DF (d) EB

Answer: D

32.5 Who amongst the following sits at the extreme right end of the row?

- (a) G (b) C
(c) I (d) H

Answer: B

Explanation-

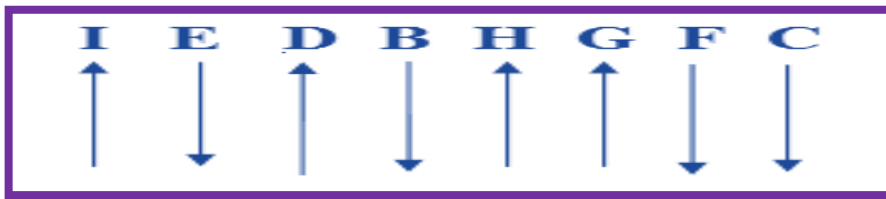

Question 33

Study the following information carefully to answer the given questions

A group of eight friends – A, C, F, S, X, M, I and W – are sitting in a straight line facing north. Each of them has different company cars– Datsun, Renault, Hyundai, Tata, Maruti, Toyota, BMW and Volkswagen. Each of them likes different colours – Pink, Yellow, Red, Black, Blue, Orange, White and Green, but not necessarily in the same order.

C, who has a Maruti car, sits third to the left of F. Neither C nor F sits at the extreme ends of the line. A, who likes Pink colour, has Hyundai car. A is not an immediate neighbour of either C or F.

S is two places away from M and likes Orange colour. M, who has BMW car, likes Red colour. I, who has Datsun car, sits at an extreme end of the line and likes White colour.

X, who has Tata car likes Green colour and sits on the immediate left of C. C does not like either Blue or Yellow colour.

One who has Volkswagen sits on the immediate left of who has Datsun car. F, who has Renault car, does not like Yellow colour.

33.1 The person who likes yellow has which company car?

- (a) Datsun (b) BMW
(c) Toyota (d) Tata

Answer: C

33.2 What is the position of F with respect to X ?

- (a) Fourth to the right
(c) Immediate right
- (b) Second to the left
(d) Third to the left

Answer: A

33.3 If A is related to black, W is related to Blue then M is related with which color ?

- (a) Green
(c) White
- (b) Orange
(d) Pink

Answer: B

33.4 Four of the following five are alike in a certain way based on their position, which one does not belong to that group?

- (a) WFI
(c) SMC
- (b) ACM
(d) XCW

Answer: D

33.5 Which of the following is correct according to the given information?

- (a) Two persons sits between W and who likes pink colour
(c) X is sit between who has Maruti and Hyundai cars
- (b) X and I are sits at the extreme end of the line
(d) Both 1 and 3

Answer: D

Explanation:

Pink	Green	Black	Yellow	Red	Blue	Orange	White
A	X	C	W	M	F	S	I
Hyundai	Tata	Maruti	Toyota	BMW	Renault	Volkswagen	Datsun

Question 34

Study the following information carefully to answer the given questions

Ten Stationery items Pencil, Books, Notes, Pens, Sharpners, Chalk, Stickers, Gum, Scale, Covers are placed in 10 boxes numbered 1, 2, 3, 4, 5, 6, 7, 8, 9 and 10 are placed adjacent to one another in two different rows of 5 boxes each.

Boxes with odd numbers are situated opposite to the boxes with even numbers and no two even number boxes with even number and no two boxes with odd numbers are adjacent to each other. No two boxes have consecutive numbers.

Box no 8 is occupied by books and it is to the extreme left of one end of the row.

Box 4 and 6 are not in the row of box no 8 and any of the boxes numbered 4, 6, and 3 are not in the middle of the row.

Gums are placed in Box no 5.and its box is not situated in the row where box no 6 is situated.

Notes are placed in an odd numbered box and placed in a row where Books are situated but both are not adjacent to each other.

Sharpner's and Chalk's box are adjacent to box no 6 and Chalk's box is not adjacent to box no 4.

Pencil's & Cover's box are placed in the same row. Pen's box is even numbered but not 10 and diagonally opposite to box no 1 which contains stickers

Box no 6 is second from the one of the end of the row. Stickers's box is neither opposite to Sharpners's box nor adjacent to it.

34.1 The pack of notes are placed in which number box ?

- (a) 7
(b) 9

(c) 8

(d) 3

Answer: A**34.2 Covers are kept in which number box?**

(a) 4

(b) 6

(c) 3.2

(d) Can't be determined

Answer: D**34.3 The number 9 box is placed opposite to which box and contains which stationery?**

(a) 5, Chalk

(b) 6, Covers

(c) 8, Pens

(d) 10, scale

Answer: D**34.4 If pencil is placed in the box numbered 4 then which box is placed opposite to the box which contains pencils?**

(a) Pencils

(b) Covers

(c) Stickers

(d) Gum

Answer: D**34.5 If the box 1 is related to Sharpners, box 10 is related to Pens then Box 8 is related with?**

(a) Scale

(b) Books

(c) Chalk

(d) Notes

Answer: A**Explanation:**

1[Stickers]	4[Pencil/Covers]	9[Sharpners]	6[Pencil/Covers]	3[Chalk]
8[Books]	5[Gum]	10[Scale]	7[Notes]	2[Pens]

Question 35**Study the following information carefully to answer the given questions**

P, Q, R, S, T, U, V and W are eight members of 3 different families who belongs to 3 different cities such as Mumbai, Mysore and Thanae. They go for shopping in 3 different cars A, B and C. Out of 8 members 4 are female. Each member of a family is travelling in a different car. Each car carries at least one male, one female and each family has at least 2 members.

P belongs to Thana and he is travelling in car C. S is wife of T and they are travelling in Car A and B. W is son of Q who is wife of V and they belong to Mysore. R is daughter of U who is wife of P. R is travelling in car B. V is not travelling with U.

35.1 Which of the following group belongs to Mumbai?

(a) T,V

(b) S,T

(c) U,W

(d) P,S

Answer: B**35.2 Which of the following group travelling in Car B ?**

(a) S,V,P

(b) R,V,W

(c) P,Q,R

Answer: D

(d) R,T,V

35.3 V belongs to which city?

(a) Mysore

(c) Thanae

Answer: A

(b) Mumbai

(d) Either Mumbai or Mysore

35.4 Which of the following is true?

(a) P travelling in Car B

(c) V travelling in Car B

Answer: C

(b) R travelling in Car A

(d) T travelling in Car C

35.5 Which of the following combination is not true?

(a) T -Mumbai - B

(c) P - Thanae - C

Answer: D

(b) W -Mysore - A

(d) W - Mumbai - B

Explanation:

Person	City	Car
P	Thana	C
Q	Mysore	C
R	Thana	B
S	Mumbai	A
T	Mumbai	B
U	Thana	A
V	Mysore	B
W	Mysore	A

Question 36**Study the following information carefully to answer the given questions**

10 people are sitting in 2 parallel rows containing 5 people each in such a way that there is an equal distance between adjacent persons. In row 1 - A, B, C, D and E are seated facing north and in row 2 - U, V, W, X and Y are seated and facing south. Each person's like different dishes- Dosa, Poori, Chapathi, Idly, Samosa, Pizza, Pongal, Parotta, Briyani and Pasta.

E is sit exactly in the centre of the row and faces the one who likes Idly. Only 1 persons sits between E and the one who likes Samosa. X faces the immediate neighbour of the one who likes Samosa. Only 1 persons sits between U and the one who likes Idly. U is not an immediate neighbour of X. U faces one of the immediate neighbours of C. D is neither an immediate neighbour of C nor faces X.

V is not an immediate neighbour of X and faces the one who likes Poori. D does not face W. D faces one of the immediate neighbours of the one who likes Pizza. Only 1 person sits between the one who likes Pizza and the one who likes Dosa. The one who likes Briyani and the one who likes Parotta face each other. Only 2 people sit between the one who likes Parotta and the one who likes Pongal. A does not like Pongal. The one who likes Pasta sits fourth to the right of the one who likes Briyani.

36.1 Which of the following dish does X likes?

- (a) Pizza (b) Pasta
(c) Poori (d) Pongal

Answer: A

36.2 Which of the following pairs represents the people sitting at the extreme ends of the row 1?

- (a) BE (b) AD
(c) AC (d) CB

Answer: B

36.3 Who among the following likes Briyani?

- (a) X (b) Y
(c) V (d) U

Answer: D

36.4 Who among the following immediate neighbors of C?

- (a) BA (b) CE
(c) AE (d) DE

Answer: D

36.5 Which of the following is correct?

- (a) A faces V (b) C faces X
(c) E faces W (d) D faces U

Answer: C

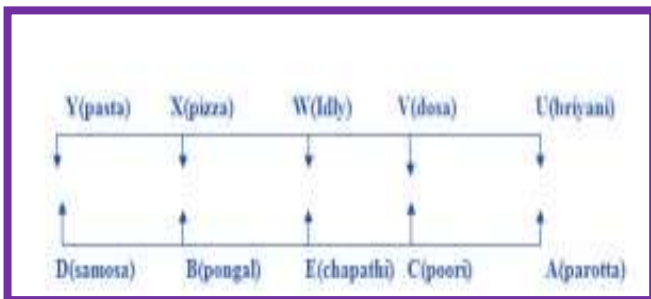

E faces W

PAST EXAMINATION QUESTIONS:

MAY 2018

Question 1

Five boys A, B, C, D and E are sitting in a row A is to the right of B, and E to the left of B but to the right of A is to the left of D. Who is second from the left end?

- (a) D (b) A
(c) E (d) B

Answer: C

Explanation:

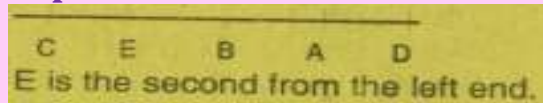

Question 2

Five senior citizens are living in a multistoried building Mr. Muan lives a flat above Mr. Ashokan, Mr. Lokesh in a flat below Mr. Gaurav, Mr. Ashokan lives in a flat below Mr. Gaurav and Mr. Rakesh lives in a flat below Mr. Lokesh.

Who lives in the top most flat?

- (a) Mr. Lokesh (b) Mr. Gaurav
(c) Mr. Manu (d) Mr. Rakesh

Answer: C

Explanation:

Mr. Manu lives in the top most flat.

Question 3

Six children A, B, C, D, E and F are standing in a row. B is between F and D. E is between A and C. A does not stand next to F or D. C does not stand next to D. F is between which of the following pairs of children?

- (a) B and E (b) B and C
(c) B and D (d) B and A

Answer: B

Explanation:

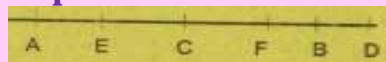

Question 4

Five children are sitting in a row. S is sitting next to P but not T. K is sitting next to R, who is sitting on the extreme left and T is not sitting next to K.

Who is/are adjacent to S.

- (a) K+P (b) R+P
(c) Only P (d) P and T

Answer: D

Explanation:

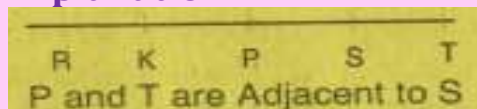

Question 5

Five boys A, B, C, D and E are sitting in a row. A is to the right of B and E is to the left of B but to the right of C. A is to the left of D. Who is second from the

left end?

- (a) D (b) A
(c) E (d) B

Answer: C

Explanation:

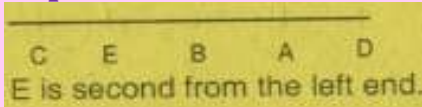

NOV 2018

Question 1

Eight persons A, B, C, D, E, F, G and H are sitting in a line. E sits second right to D. H sits fourth left to D. C and F are immediate neighbours, but C is not immediate neighbor of A. G is not neighbor of E. Only two persons sit between A and E. The persons on left end and right end respectively are

- (a) G and E (b) B and E
(c) H and E (d) G and B

Answer: A

Explanation:

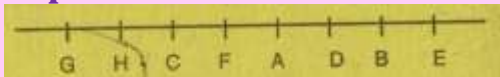

The Person on the left end = G

The Person On the right end = E

Question 2

Six children A, B, C, D, E and F are sitting in a row. B is between F and D. E is between A and C. However, A does not sit next to F or D. C does not sit next to D. Then, F is sitting between;

- (a) B and C (b) E and C
(c) B and D (d) None of the above

Answer: A

Explanation:

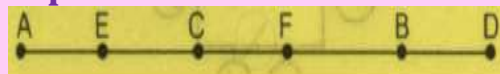

F is sitting b/w B and C

Question 3

Five students A, B, C, D and E are standing in a row. D is on the right of E, B is on the left of E but on the right of A. D is next to C on his left. The student in middle is

- (a) B (b) E
(c) C (d) A

Answer: B

Explanation:

The student in middle is 'E'

MAY 2019**Question 1**

Five boys A, B, C, D, E are sitting in a row A is to the right of B and E is to the left of B but to the right of C. A is to the left of D who is second from the left end?

- (a) D (b) A
(c) E (d) B

Answer: C

Explanation:

C E B A D

Question 2

5 children are sitting in a row. S is sitting next to P but not T. K is sitting next to R. K is sitting on extreme end. T is not sitting next to K. Who are sitting adjacent to S.

- (a) K & P (b) R & P
(c) Only P (d) P & T

Answer: D

Explanation:

P S T R K

Question 3

Four girls are seated for a photograph. Shikha is left of Reena. Manju is to the right of Reena. Rita is between Reena and Manju. Who is the second left in photograph?

- (a) Reena (b) Manju
(c) Rita (d) Shikha

Answer: C

Explanation:

Shikha, Reena, Rita, Manju



2nd Left

Question 4

Which of the following people are sitting to the right of S?

- (a) OTPQ (b) OTPR
(c) UNVM (d) UOTPR

Answer: B

Explanation:

The arrangement of the persons is Q W M V N U S O T P R O T P R are sitting to the right of S.

NOV 2019**Question 1**

Six person are sitting in a circle facing the circler Parikh is between Bablu and Narender Ashok is between Chitra and Pankaj. Chitra is immediate left of Bablu. Who is immediate right of Bablu?

- (a) Parikh (b) Pankaj
(c) Narender (d) Chitra

Answer: A**Explanation:**

According to question;

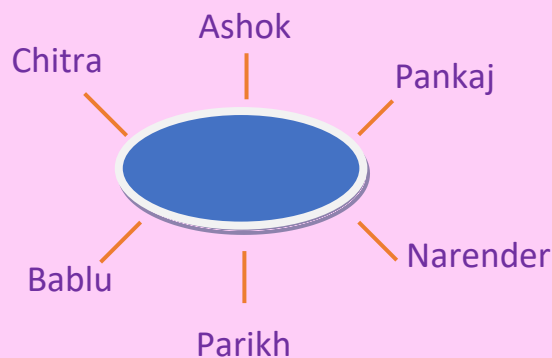

So Parikh is immediate right of Bablu.

Question 2

C is between A and B. € is at the extreme right D is on the left of Who is at the middle?

- (a) A (b) B
(c) D (d) E

Answer: B**Explanation:**

According to question,

A € B D E

So B is in the middle.

Question 3

5 person are standing in a line one of the 2 persons at the extreme ends is a professor and other a business max. An advocate is standing to the right of student. An author is to the left of the business man. The student is standing between the professor and advocate. Counting from left. The author is at which place?

- (a) 2
- (b) 3
- (c) 4
- (d) none

Answer: C

Explanation:

According to given ques;

Professor Student Advocate Author Businessman

Author is 4th from the left.

IAN 2021

Question 1

A, B, C and D are playing cards. A and B are partners. D faces towards north. If A faces west, then who faces south?

- (a) C
- (b) B
- (c) D
- (d) Data inadequate

Answer: A

Explanation:

As per the data D faces North A faces towards west So its partner B will face towards A and hence towards East So C who will face D will face towards south.

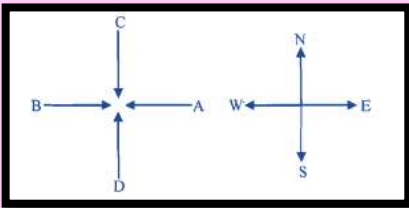

Question 2

A is seated between D and F at a round table. C is seated opposite to D. E is round adjust to D. who sis opposite to B?

- (a) A
- (b) D
- (c) C
- (d) F

Answer: a

Explanation:

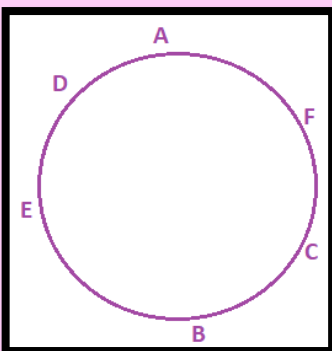

WHO IS UPPER

Question 3

For Indian A, B, C and D and four Chinese E, F, G and H are sitting in a circle around a table facing the each other in a conference. No two Indians or Chinese are sitting side by side, C who is sitting between G and F is being D, F is between D and A and facing G, H is to the right of B. who is sitting left of A?

- (a) E (b) F
(c) G (d) H

Answer: a

Explanation:

Question 4

Five friends A, B, C, D and E are sitting on a bench. A is sitting next to B; C is setting next to D, D is not sitting with E; E is at the left end of bench. C is on second position from the right; A is on the right side of B and to the right side of E. A and C are sitting together. What is the position of B?

- (a) Second from right (b) Centre
(c) Extreme left (d) Second from left

Answer: d

Explanation:

JULY 2021

Question 1

A, B, C, D and E are sitting on a bench. A is sitting next to B, C is on the left end of the bench. C is on the second position from the right. A is to the right of B and E. A I and C are sitting together. In which position A is sitting between?

- (a) C and D (b) D and E
(c) B and C (d) B and E

Answer: Options (c)

Explanation:

Between B and C

.

E B A C D

Therefore, A is sitting in between B and C.

Question 2

Five girls are sitting on a bench to be photographed. Seema is to the left of Rani and to the right of Bindu. Mary is to the right of Rani. Reeta is between Rani and Mary. Who is sitting immediate right to Reeta?

- (a) Seema (b) Rani
(c) Bindu (d) Mary

Answer: Options (d)**Explanation**

We are given that five girls are sitting on a bench to be photographed.

Seema is to the left of Rani and to the right of Bindu.

So, sequence (Facing towards photographer): Rani, Seema, Bindu

So, Seema is to the left of Rani and to the right of Bindu.

Now we are given that Mary is to the right of Rani

Sequence: Mary, Rani, Seema, Bindu

Now we are given that Reeta is between Rani and Mary

So, Sequence: Mary, Reeta, Rani, Seema, Bindu

Now we are asked who is sitting immediate right to Reeta

Ans: Mary is sitting immediate right to Reeta.

Question 3

Six friends P, Q, R, S, T and U are sitting around the hexagonal table each at one corner and are facing the centre of the hexagonal. P is second to the left of U. Q is neighbour of R and S. T is second to the left of S. Which one is sitting opposite to S?

(a) R

(b) P

(c) Q

(d) T

Answer: Options (b)**Explanation:**

S is sitting opposite to P

Step-by-step explanation:

Let mark corners

1 2 3 4 5 6 clock wise

P is second to the left of U

Assume P is at 1 then U would be at 3

Q is a neighbour of R and S

=> Q, must be at 5 & R & S would be at 2 & 4

Hence at remaining position 2 would be T

T is second to the left of S

=> S will be at 4

P is at 1 so opposite is 4 - S

S is sitting opposite to P

Question 4

A, B, C, D, E, F and G are sitting in a row facing North:

1. F is to the immediate right of E

2. E is 4th to the right to G

3. C is the neighbour of B and D

4. Person who is third to the left of D is at one of ends

Who are right of D?

(a) E and F only

(b) G, b and C

(c) E, F and A

(d) G and B only

Answer: Options (c)

DEC 2021

Question 1

Six children, named as P Q, R, S, T and U, are sitting in a row, Q is between U and S, T is between P and R, P does not sit next to either U or S. R does not sit next to S. So, U is sitting between the pairs of children.

(a) Q and T

(b) Q and R

(c) Q and S

(d) Q and P

Answer: b

Explanation:

P T R U Q S

Question 2

Five persons A, B, C, D and E are sitting in a row. A sits left to C and C sits left to B. E sits right to B, D sits in between E and B. Who is sitting in the middle?

(a) B

(b) C

(c) E

(d) D

Answer: a

Explanation:

A C B D E

Question 3

Four ladies A, B, C and D and four Gentlemen E, F, G and H are sitting in a circle around a table facing each other.

I. No two ladies or gentleman are sitting side by side.

II. C, who is sitting between G and E, is facing D.

III. F is between D and A facing G.

IV. H is to the right of B.

Who is immediate neighbour of B?

(a) G and H

(b) E and F

(c) E and G

(d) A and B

Answer: a

Explanation:



Question 4

Persons M, N, O, P, Q, R, S, and T are sitting on a compound wall facing North. O sits fourth left of S; P sits second to the right of S; only two people sit between P and M; N and R are immediate neighbours of each other. N is not an immediate neighbour of M; T is not the neighbour of P. How many persons are seated between M and Q?

- (a) One
- (b) Two
- (c) Three
- (d) Four

Answer: a

Explanation:

T O N R M S Q P

Question 5

In a line, P is sitting 13th from left. Q is sitting 24th from the right and 3rd left from P. How many people are sitting in the line?

- (a) 34
- (b) 31
- (c) 32
- (d) 33

Answer:

Explanation:

Q is sitting 3rd left of P, and Q is the 24th position from the right.

..	10th	11th	12th	13th	14th	15th	..
	Q						

Since Q is 24th and 3rd left of P, it means Q is on the 10th place from the left. This means that counting the position of Q, there are 24 positions to the right. Therefore, counting from 11th position, there are 23 positions to the right. Therefore, total number of places = 10 + 23 = 33.

JUNE 2022

Question 1

If six person are sitting in a hexagonal table are P, Q, R, S, T, U each facing the centre. P is seated to opposite to Q who is b/w R & S. P is b/w T and U. T is the left of S. Which of them facing R?

- (a) P
- (b) Q
- (c) U
- (d) T

Answer: Options (d)

Explanation:

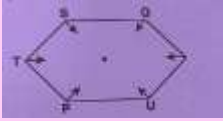

T is the facing of R

Question 2

Five boys A, B, C, D, E, are sitting in a row. A is the right of B and E is to the left of B, but to the right of C. A is to left of D. Who is second from the left end?

- (a) D
- (b) A
- (c) E
- (d) B

Answer: Options (2)

Explanation:



'E is the second from the left end'

DEC 2022

Question 1

P, Q, R, S and T are sitting in a line facing West. P and Q are sitting together. R is sitting at south end and S is sitting at North end. T is neighbour of Q and R. Who is sitting the middle?

- a) P
- b) Q
- c) R
- d) S

Answer: Options (b)

Explanation:

1) R is sitting at south end and S is sitting at north end.

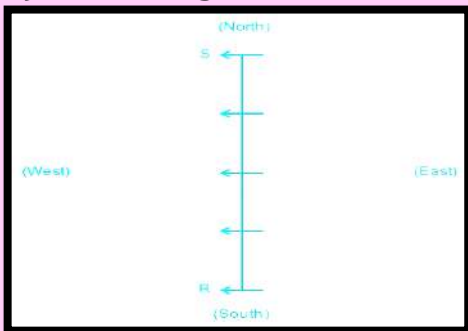

2) T is neighbour of Q and R. P and Q are sitting together.

CHAPTER - 12 BLOOD RELATIONS

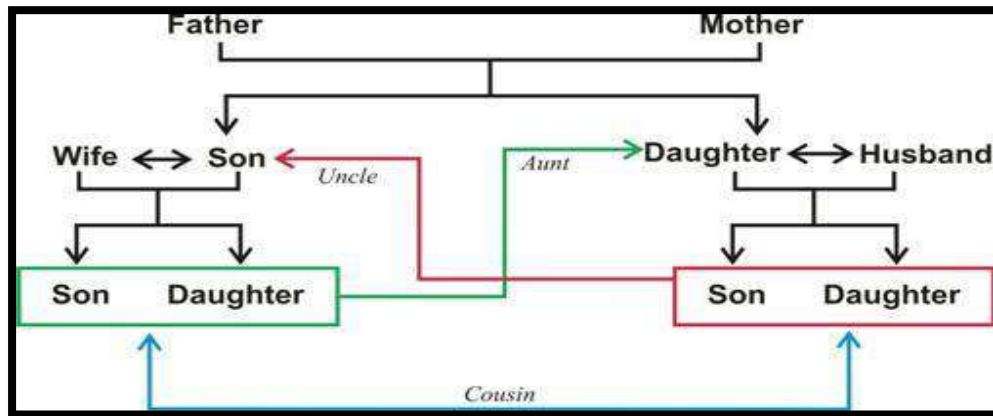

A person who is related to another by birth rather than by marriage.

Family or Blood Relationship means persons connected by relations like – father-mother, son-daughter, brother-sister, grandfather-grandmother, uncle-aunty, nephew-niece, brother-in-law, sister-in-law etc. The list can go on and on adding members from father’s side and mother’s side etc.

S.no	Relationship	Commonly Used Terms
1	Father's son (or) mother's son	Brother
2	Father's daughter (or) mother's daughter	Sister
3	Mother's brother	Uncle (Paternal Uncle)
4	Father's brother	Uncle (Maternal Uncle)
5	Mother's sister	Aunt (Paternal Aunt)
6	Father's sister	Aunt (Maternal Aunt)
7	Son's wife	Daughter-in-law
8	Daughter's husband	Son-in-law
9	Sister's husband	Brother-in-law
10	Husband's brother (or) wife's brother	Brother-in-law
11	Brother's wife	Sister-in-law
12	Husband's sister (or) wife's sister	Sister-in-law
13	Husband's father (or) wife's father	Father-in-law
14	Husband's mother (or) wife's mother	Mother-in-law
15	Brother's son (or) sister's son	Nephew
16	Brother's daughter (or) Sister's	Niece
17	Uncle's daughter (or) Aunt's daughter	Cousin
18	Uncle's Grand son (or) Aunt's Grand son	Nephew
19	Father's father (or) mother's father	Grandfather
20	Father's mother (or) mother's mother	Grandmother
21	Father of Grandfather or Father of grandmother	Great Grandmother
22	Father of Grandfather (or) father of grandmother	Great Grandfather

**Question 1**

Pointing to a photograph of a boy Shinzo said, "He is the son of the only son of my mother." How is Shinzo related to that boy?

- (a) Father (b) Brother
(c) Uncle (d) Cousin

Answer: a

Explanation:

The boy in the photograph is the only son of the son of Shinzo's mother i.e., the son of Shinzo. Hence, Shinzo is the father of boy.

Question 2

If $A + B$ means A is the mother of B ; $A - B$ means A is the brother B ; $A \% B$ means A is the father of B and $A \times B$ means A is the sister of B , which of the following shows that P is the maternal uncle of Q ?

- (a) $Q - N + M \times P$ (b) $P + S \times N - Q$
(c) $P - M + N \times Q$ (d) $Q - S \% P$

Answer: C

Explanation:

$P - M \rightarrow P$ is the brother of M

$M + N \rightarrow M$ is the mother of N

$N \times Q \rightarrow N$ is the sister of Q

Therefore, P is the maternal uncle of Q

Question 3

If A is the brother of B ; B is the sister of C ; and C is the father of D , how D is related to A ?

- (a) Brother (b) Sister
(c) Nephew (d) Cannot be determined

Answer: D

Explanation:

If D is Male, the answer is Nephew.

If D is Female, the answer is Niece.

As the sex of D is not known, hence, the relation between D and A cannot be determined.

Note: Niece - A daughter of one's brother or sister, or of one's brother-in-law or sister-in-law.

Nephew - A son of one's brother or sister, or of one's brother-in-law or sister-in-law

Question 4

If $A + B$ means A is the brother of B ; $A - B$ means A is the sister of B and $A \times B$

means A is the father of B. Which of the following means that C is the son of M?

- (a) $M - N \times C + F$
 (c) $N + M - F \times C$

- (b) $F - C + N \times M$
 (d) $M \times N - C + F$

Answer: D

Explanation:

$M \times N \rightarrow$ M is the father of N

$N - C \rightarrow$ N is the sister of C

and $C + F \rightarrow$ C is the brother of F.

Hence, M is the father of C or C is the son of M

Question 5

Introducing a boy, a girl said, "He is the son of the daughter of the father of my uncle." How is the boy related to the girl?

- (a) Brother
 (c) Uncle

- (b) Nephew
 (d) Son-in-law

Answer: A

Explanation:

The father of the boy's uncle \rightarrow the grandfather of the boy and daughter of the grandfather \rightarrow sister of father

Question 6

Pointing to a photograph Lata says, "He is the son of the only son of my grandfather." How is the man in the photograph related to Lata?

- (a) Brother
 (c) Cousin

- (b) Uncle
 (d) Data is inadequate

Answer: A

Explanation:

The man in the photograph is the son of the only son of Lata's grandfather i.e., the man is the son of Lata's father. Hence, the man is the brother of Lata.

Question 7

If $A + B$ means A is the brother of B; $A \times B$ means A is the son of B; and $A \% B$ means B is the daughter of A, then which of the following means M is the maternal uncle of N?

- (a) $M + O \times N$
 (c) $M + O \% N$

- (b) $M \% O \times N + P$
 (d) None of these

Answer: D

Explanation:

Because the sex of O is not known

Question 8

If D is the brother of B, how B is related to C? To answer this question which of the statements is/are necessary?

The son of D is the grandson of C.

B is the sister of D.

- (a) Only 1
(c) Either 1 or 2

- (b) Only 2
(d) 1 and 2 both are required

- Only 1
Either 1 or 2

Answer: D

Explanation:

Given: D is the brother of B.

From statement 1, we can detect that D is son of C (son of D is the grandson of C).

From statement 2, we can detect that B is 'Female' (sister of D).

Therefore, B is daughter of C.

Question 9

If A + B means A is the father of B; A - B means A is the brother B; A % B means A is the wife of B and A x B means A is the mother of B, which of the following shows that M is the maternal grandmother of T?

- (a) $M \times N \% S + T$
(c) $M \times S - N \% T$

- (b) $M \times N - S \% T$
(d) $M \times N \times S \% T$

- Only 1
Either 1 or 2

Answer: A

Explanation:

$M \times N \rightarrow$ M is the mother of N

$N \% S \rightarrow$ N is the wife of S

And $S + T \rightarrow$ S is the father of T.

Hence, M is the maternal grandmother of T

Question 10

Pointing to a photograph. Bajpai said, "He is the son of the only daughter of the father of my brother." How Bajpai is related to the man in the photograph?

- (a) Nephew
(c) Father

- (b) Brother
(d) Maternal Uncle

Answer: D

Explanation:

The man in the photo is the son of the sister of Bajpai. Hence, Bajpai is the maternal uncle of the man in the photograph

Question 11

Deepak said to Nitin, "That boy playing with the football is the younger of the two brothers of the daughter of my father's wife." How is the boy playing football related to Deepak?

- (a) Son
(c) Cousin

- (b) Brother
(d) Brother-in-law

- Only 1
Either 1 or 2

Answer: B

Explanation:

Father's wife \rightarrow mother. Hence, the daughter of the mother means sister and sister's younger brother means brother. Therefore, the boy is the brother of Deepak.

Question 12

Pointing a photograph X said to his friend Y, "She is the only daughter of the father of my mother." How X is related to the person of photograph?

- (a) Daughter (b) Son
(c) Nephew (d) Cannot be decided

Only 1
Either 1 or 2

Answer: B

Explanation:

'The only daughter of the father of X's mother' means mother of X.

Hence X is the son of the lady in the photograph.

Note: Still have doubt like "How X is a male?"

Question 13

Veena who is the sister-in-law of Ashok, is the daughter-in-law of Kalyani. Dheeraj is the father of Sudeep who is the only brother of Ashok. How Kalyani is related to Ashok?

- (a) Mother-in-law (b) Aunt
(c) Wife (d) None of these

Only 1
Either 1 or 2

Answer: D

Explanation:

Ashok is the only brother of Sudeep and Veena is the sister-in-law of Ashok. Hence Veena is the wife of Sudeep. Kalyani is the mother-in-law of Veena. Kalyani is the mother of Ashok.

Question 14

If A + B means A is the sister of B; A x B means A is the wife of B, A % B means A is the father of B and A - B means A is the brother of B. Which of the following means T is the daughter of P?

- (a) P x Q % R + S - T (b) P x Q % R - T + S
(c) P x Q % R + T - S (d) P x Q % R + S + T

Only 1
Either 1 or 2

Answer: B

Explanation:

P x Q → P is the wife of Q

Q % R → Q is the father of R

R - T → R is the brother of T

T + S → T is the sister of S.

Therefore, T is the daughter of P.

Question 15

Pointing to a woman, Abhijit said, "Her granddaughter is the only daughter of my

brother." How is the woman related to Abhijit?

- (a) Sister (b) Grandmother
(c) Mother-in-law (d) Mother

Only 1
Either 1 or 2

Answer:D

Explanation:

Daughter of Abhijit's brother → niece of Abhijit. Thus the granddaughter of the woman is Abhijit's niece.

Hence, the woman is the mother of Abhijit.

Question 16

Amit said - "This girl is the wife of the grandson of my mother". How is Amit related to the girl?

- (a) Brother (b) Grandfather
(c) Husband (d) Father-in-law

Only 1
Either 1 or 2

Answer:D

Explanation:

The girl is the wife of grandson of Amit's mother i.e., the girl is the wife of son of Amit. Hence, Amit is the father-in-law of the girl.

Question 17

A and B are children of D. Who is the father of A? To answer this question which of the statements (1) and (2) is necessary?

1. C is the brother of A and the son of E.

2. F is the mother B.

- (a) Only (1) (c) Only (2)
(b) Either (1) or (2) (d) (1) and (2) both

Only 1
Either 1 or 2

Answer: B

Explanation:

A and B are children of D.

From (1), C is the brother B and son of E.

Since, the sex of D and E are not known. Hence (1) is not sufficient to answer the question.

From (2), F is the mother of B. Hence, F is also the mother of A. Hence D is the father of A.

Thus, (2) is sufficient to answer the question.

Question 18

Pointing towards a man, a woman said, "His mother is the only daughter of my mother." How is the woman related to the man?

- (a) Mother (b) Grandmother
(c) Sister (d) Daughter

Only 1
Either 1 or 2

Answer:A

Explanation:

Only daughter of my mother → myself.

Hence, the woman is the mother of the man.

Question 19

If P \$ Q means P is the brother of Q; P # Q means P is the mother of Q; P * Q means P is the daughter of Q in A # B \$ C * D, who is the father?

(a) D

(b) B

Only 1

(c) C

(d) Data is inadequate

Either 1 or 2

Answer: A

Explanation:

A is the mother of B, B is the brother of C and C is the daughter of D. Hence, D is the father.

A (Parents) D

| |
| |

B - is - Brother - of - C

Question 20

Introducing Sonia, Aamir says, "She is the wife of only nephew of only brother of my mother." How Sonia is related to Aamir?

(a) Wife

(b) Sister

Only 1

(c) Sister-in-law

(d) Data is inadequate

Either 1 or 2

Answer: A

Explanation:

Brother of mother means maternal uncle. Hence only nephew of Aamir's maternal uncle means Aamir himself. Therefore, Sonia is the wife of Aamir

Question 21

If A + B means A is the brother of B; A % B means A is the father of B and A x B means A is the sister of B. Which of the following means M is the uncle of P?

(a) M % N x P

(b) N x P % M

Only 1

(c) M + S % R % P

(d) M + K % T x P

Either 1 or 2

Answer: D

Explanation:

M + K → M is the brother of K

K % T → K is the father of T

T x P → T is the sister of P

Therefore, K is the father of P and M is the uncle of P.

Question 22

Pointing to Varman, Madhav said, "I am the only son of one of the sons of his

father." How is Varman related to Madhav?

- (a) Nephew (b) Uncle
(c) Father or Uncle (d) Father

Only 1
Either 1 or 2

Answer: C

Explanation:

Madhav is the only son of one of the sons of Varman's father → Either Varman is the father or uncle of Madhav.

Question 23

Introducing a woman, Shashank said, "She is the mother of the only daughter of my son." How that woman is related to Shashank?

- (a) Daughter (b) Sister-in-law
(c) Wife (d) Daughter-in-law

Only 1
Either 1 or 2

Answer: D

Explanation:

The woman is the mother of Shashank's granddaughter. Hence, the woman is the daughter-in-law of Shashank.

Question 24

If A + B means B is the brother of A; A x B means B is the husband of A; A - B means A is the mother of B and A % B means A is the father of B, which of the following relations shows that Q is the grandmother of T?

- (a) $Q - P + R \% T$ (b) $P \times Q \% R - T$
(c) $P \times Q \% R + T$ (d) $P + Q \% R - T$

Only 1
Either 1 or 2

Answer: A

Explanation:

$Q - P \rightarrow Q$ is the mother of P

$P + R \rightarrow R$ is the brother of P

Hence, $\rightarrow q$ is the mother of R

$R \% T \rightarrow R$ is the father of T.

Hence, Q is the grandmother of T

Question 25

A3P means A is the mother of P

A4P means A is the brother of P

A9P means A is the husband of P

A5P means A is the daughter of P

Which of the following means that K is the mother-in-law of M?

- (a) M9N3K4J (b) M9N5K3J
(c) K5J9M3N (d) K3J9N4M

Only 1
Either 1 or 2

Answer: B

Explanation:

M9N → M is the husband of N

N5K → N is the daughter of K

Hence, → M is the son-in-law of K

K3J → K is the mother of J

Hence, → K is a lady

Hence, → K is the mother-in-law of M

Question 26

Introducing Neeta, Anil said, 'She is wife of my mother's only son. How is Neeta related to Anil?'

(a) Mother

(b) Wife

(c) Sister

(d) Daughter-in-law

Answer: B

Explanation:

Neeta is the wife of Anil's mother's only son, who is Anil himself. Hence, answer is Neeta is Anil's wife. i.e. **(B) Wife.**

Question 27

'Ram' is the father of 'Kusha' but 'Kusha' is not his son. 'Mala' is the daughter of 'Kusha'. 'Shalaka' is the spouse of 'Ram'. 'Gopal' is the brother of 'Kusha'. 'Hari' is the son of 'Gopal'. 'Meena' is the spouse of 'Gopal'. 'Ganpat' is the father of 'Meena'. Who is the granddaughter of 'Ram'?

(a) Hari

(b) Mala

(c) Meena

(d) Shalaka

Answer: B

Explanation:



'Mala' is the daughter of 'Kusha' and 'Ram' is the father of 'Kusha'. So, 'Mala' is the granddaughter of 'Ram'. Hence,

Question 28

Pointing to a gentleman, Dinesh said "His only brother is the father of my daughter's father." How is the gentleman related to Dinesh?

(a) Uncle

(b) Grandfather

(c) Father

(d) Brother- in-law

Answer: A

Explanation:

The gentleman's only brother is the father of Dinesh (Dinesh daughter's father is Dinesh himself.). Gentleman is brother of Dinesh's father. Gentleman is Dinesh's uncle. Hence,

Question 29

Pointing to Ajay, Radha said, "His father is the only son of my grandfather". How is Radha Related to Ajay?

- (a) Brother (b) Sister
(c) Mother (d) Daughter

Answer: B

Explanation:

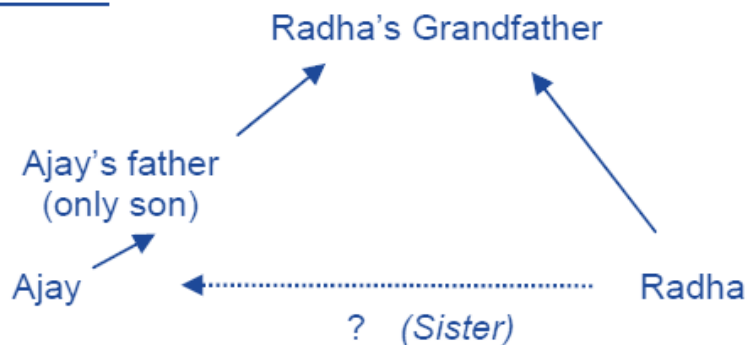
Traditional Method

When Radha's Grandfather's only son is Ajay's father, then Ajay's father is also the father of Radha. So Radha is Ajay's sister. Hence, **answer is (B) Sister**.

We know, 'Only son of my grandfather' means 'my father'. "His father is the only son of my grandfather" thus becomes "His father is my father". So Radha is Ajay's sister. Hence,

Question 30

Lalita said to Tina, "You are the daughter-in-law of the grandmother of my father's only son." How is Lalita related to Tina?

- (a) Aunt (b) Sister
(c) Mother (d) Indeterminable

Answer: D

Explanation:

'My father's only son' is my (Lalita's) brother. Tina is daughter-in-law of grandmother of (Lalita's) brother. Tina thus can be their mother (wife of grandmother's only son). However, as it is not mentioned that the grandmother has only one son, Tina can be wife of grandmother's other son i.e. Tina could also be their aunt. Hence,

Question 31

Pointing to a photograph, Amar said, "I have no brother or sister but that man's father is my father's son." Whose photograph, was it?

- (a) a. His son's (b) b. His father's
(c) c. His nephew's (d) d. His own

Answer: A

Explanation:

Since Amar has no brother or sister so his father's son is the man himself and so the man who is talking is the father of the man in the photograph i.e. the man in the photograph is his son.

Hence, answer is (A) His son's.

Question 32

Looking at the portrait of a man, Ashok said, 'His mother is the wife of my father's son. Brothers and sisters I have none'. At whose portrait was Ashok looking?

- (a) a. His cousin (b) b. His nephew
(c) c. His uncle (d) d. His son

Answer: D

Explanation:

My (Ashok's) father's son will be Ashok himself as he has no brother or sister. Ashok's wife is mother of the person in the portrait. The portrait is thus of Ashok's own son. Hence, **answer is (D) His Son.**

Question 33

Pointing to a photograph of a boy Suresh said, "He is the son of the only son of my mother." How is Suresh related to that boy?

- (a) Brother (b) Uncle
(c) Cousin (d) Father

Answer: D

Explanation:

The boy in the photograph is the only son of the son of Suresh's mother i.e., the son of Suresh. Hence, Suresh is the father of boy.

Question 34

When Anuj saw Manish, he recalled, "He is the son of the father of my daughter." Who is Manish?

- (a) Brother-in-law (b) Brother
(c) Cousin (d) Uncle

Answer: A

Explanation:

Anuj's daughter's mother — Anuj's wife;
Anju's wife's father - Anuj's father-in-law;
Father-in-law's son — Anuj's brother-in-law
So, Manish is Anuj's brother-in-law

Question 35

A has 3 children. B is the brother of C and C is the sister of D, E who is the wife of A is the mother of D. There is only one daughter of the husband of E. What is the relation between D and B?

- (a) A (b) B
(c) C (d) D

Answer: D

Explanation:

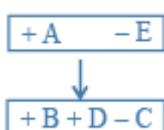

With the chart Therefore, D is a boy because there is only one daughter of E.

Hence, B is the brother of D.

Note: While solving the question (+) can be used for male and (-) can be used for female.

Question 36

If $A + B$ means A is the mother of B; $A \times B$ means A is the father of B; $A \$ B$ means A is the brother of B and $A @ B$ means A is the sister of B, then which of the following means P is the son of Q?

(a) $a. Q + R @ P @ N$

(b) $b. Q + R \$ P @ N$

(c) $c. Q \times R \$ P @ N$

(d) $d. Q + R \$ P \$ N$

Answer: D

Explanation:

$Q + R = Q$ is the mother of R

$R \$ P = R$ is the brother of P

$P \$ N = P$ is the brother of N

Therefore, P is the son of Q.

Question 37

There are six persons playing cricket namely U, V, W, X, Y and Z. U and Y are brothers. Z is the sister of Y. W is the only son of U's uncle. V and X are the daughters of the brother of W's father. How is W related to Z?

(a) Cousin

(b) Father

(c) Mother

(d) wife

Answer: A

Explanation:

Z is Y's sister and hence U's sister, which means W is also the son of Z's uncle. So, W is Z's cousin.

Question 38

$X - Z$ means X is the mother of Z; $X \times Z$ means X is the father of Z and $X + Z$ means X is the daughter of Z. Now, if $M - N \times T + Q$, then which of the following is not true?

(a) T is N's daughter.

(b) N is wife of Q

(c) M is mother-in-law of Q

(d) Q is wife of N.

Answer: B

Explanation:

$M - N \times T + Q$

M is the mother of N who is the father of T who is the daughter of Q. So, M is the grandmother of the daughter of Q, i.e., M is the mother-in-law of Q.

Hence (B) is not true.

Question 39

If ' $A \times B$ ' means 'B is father of A', ' $A + B$ ' means 'A is wife of B' and ' $A \div B$ ' means 'A is brother of B', then, what is the relation of J with L in ' $J + H \div R \times L$ '?

(a) Daughter

(b) Daughter-in-law

(c) Sister-in-law

(d) Cannot be determined

Answer: B

Explanation:

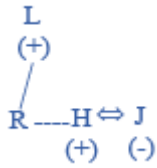

J is R's brother's wife. L is the father of H and R.
Hence, J is daughter-in-law of L.

Question 40

A is B's sister. C is B's mother. D is C's father. E is D's mother. Then, how is A related to D?

- (a) a. Grandfather (b) b. Grandmother
(c) c. Daughter (d) d. Granddaughter

Answer: D

Explanation:

A is the sister of B and B is the daughter of C.
So, A is the daughter of C. Also, D is the father of C.
So, A is the granddaughter of D.

Question 41

P is the brother of Q and R. S is R's mother. T is P's father. Which of the following statements cannot be definitely true?

- (a) a. T is Q's father (b) b. S is P's mother
(c) c. P is S's son (d) d. Q is T's son

Answer: D

Explanation:

P, Q, R are children of same parents. So, S who is R's mother and T, who is R's father will be mother and father of all three.
However, it is not mentioned whether Q is male or female So, D cannot be definitely true.

Question 42

Pointing to a person, a man said to a woman, "His mother is the only daughter of your father." How was the woman related to the person?

- (a) Aunt (b) Mother
(c) Wife (d) Daughter

Answer: A

Explanation:

Daughter of your father — Your sister. So, the person's mother is woman's sister or the woman is person's aunt.

Question 43

A girl introduced a boy as the son of the daughter of the father of her uncle. The boy is girl's

- (a) a. Brother (b) b. Son
(c) c. Uncle (d) d. Son-in-law

Answer: A

Explanation:

Daughter of uncle's father — Uncle's sister — Mother;

Mother's son — Brother

Question 44

Pointing out to a lady, a girl said, "She is the daughter-in-law of the grandmother of my father's only son." How is the lady related to the girl?

- (a) Sister-in-law (b) Mother
(c) Aunt (d) Can't be determined

Answer: D

Explanation:

Girl's father's only son— Girl's brother. Daughter in law of girl's grandmother can be their mother, or maternal uncle's wife, i.e. aunt. So relation cannot be determined.

Question 45

Pointing to a lady, a man said, "The son of her only brother is the brother of my wife." How is the lady related to the man?

- (a) Mother's sister (b) Grandmother
(c) Mother-in-law (d) Sister of father-in-law

Answer: D

Explanation:

Brother of my wife — My brother-in-law; Son of lady's brother is the brother-in-law of the man.

So lady's brother is man's father-in-law
i.e., the lady is the sister of man's father-in-law.

Question 46

A woman introduces a man as the son of the brother of her mother. How is the man, related to the woman?

- (a) Nephew (b) Son
(c) Cousin (d) Uncle to Grandson

Answer: C

Explanation:

Brother of mother — Uncle: Uncle's son — Cousin

Question 47

In a family, there are six members A, B, C, D, E and F.

A and B are a married couple, A being the male member. D is the only son of C, who is the brother of A. E is the sister of D. B is the daughter-in-law of F, whose husband has died.

How is E related to C?

- (a) a. Sister (b) b. Daughter
(c) c. Cousin (d) D. Mother

Answer: B

Explanation:

A is a male and married to B. So, A is the husband and B is the wife. C is the brother of A. D is the son of C. E. who is the sister of D will be the daughter of C. B is the daughter-in-law of F whose husband has died means F is the mother of A.

Clearly. E is the daughter of C.

Question 48

There are six persons A, B, C, D, E and F. C is the sister of F. B is the brother of E's

husband. D is the father of A and grandfather of F. There are two fathers, three brothers and a mother in the group. Who is the mother?

- (a) A (b) B
(c) C (d) E

Answer: D

Explanation:

D is father of A and grandfather of F. So, A is father of F.

Thus, D and A are the two fathers. C is the sister of F So, C is the daughter of A.

Since there is only one mother, it is evident that E is the wife of A and hence the mother of C and F.

So, B is brother of A There are three brothers. So, F is the brother of C.

Clearly, A is E's Husband.

Question 49

Introducing a man, a woman said, 'He is the only son of my mother's mother.'" How is the woman related to the man?

- (a) Mother (b) Aunt
(c) Sister (d) Niece

Answer: D

Explanation:

My mother's mother — My grandmother: My grandmother's only son — My maternal uncle. So, the woman is man's niece.

PAST EXAMINATION QUESTIONS:

MAY 2018

Question 1

Vinod introduce Vishal as the son of the only brother of his father's wife. How is Vinod related to Vishal?

- (a) Cousin (b) Brother
(c) Son (d) Uncle

Answer: A

Vinod Introduces Vishal as the Son of the only brother of his father's wife then Vinod is cousin of Vishal.

Question 2

Suresh introduces a man as "he is the son of the woman who is the mother of the husband of my mother". How Suresh is related to the man?

- (a) Brother-in-law (b) Son
(c) Brother (d) Nephew

Answer: B

Suresh introduces a man as "he is the son of the woman who is **the** mother of the husband of my mother". Then Suresh is the 'Son' the man.

Question 3

A reads a book and find the name of the author familiar. The author' is the paternal uncle of C. C is the daughter of A. How is C related to A

- (a) Brother (b) Sister
(c) Father (d) Uncle

Answer: A



Question 4

P and Q are brothers R and S are sisters. P's son is R's brother. How is Q related to R?

- (a) Uncle (b) Brother
(c) Father (d) Grandfather

Answer: A



As P is father of S and P is its brother so they are uncle and nephew
So, relationship between Q and R is of Uncle.

NOV 2018

Question 1

Pointing to a man in a photograph, a woman said, "the father of his brother is the only son of my grandfather", how is the woman related to man in the photograph?

- (a) Mother (b) Aunty
(c) Daughter (d) Sister

Answer: D

Explanation:

The father of his brother is the only son of my grandfather. So, the woman is man's sister.

Only son of women's grandfather = woman's father Man's brother's father-man's

father so. The women is man's sister.

Question 2

Six persons are seen together in a group. They are A, B, C, D, E and F, B is brother of D, but D is not brother of B. F is brother of B, C and A are married together. F is son of C, but C is not mother of F. E is brother of A. The number of female member in the group is

- (a) 1 (b) 2
(c) 3 (d) 4

Answer: B



No. of female members = 2

Question 3

Ram and Mohan are brothers, Shankar is Mohan's father. Chhaya is Shankar's sister. Priya is Shankar's niece. Shubhra is Chhaya's granddaughter. Then Ram is Shubhra's.

- (a) Brother (b) Uncle
(c) Cousin (d) Nephew

Answer: B



Ram is the uncle of Shubhra.

Question 4

If P + Q means P is the mother of Q. P ÷ Q means P is the father of Q. P-Q means P is the sister of Q. Then which of the following relationship shows that M is the daughter of R?

- (a) R + M+N (b) R + N +M
(c) R - M+N (d) None of the above

Answer: A

M+N i.e., R is the father of M.
 Hence, R: M+N clearly means
 That, M is the daughter of R.

MAY 2019

Question 1

Pointing to a photograph, a Man said “His Mother husband’s sister is my aunt”. Then what is relation between a man and he?

- (a) Son (b) Uncle
(c) Nephew (d) Brother

Answer: D

Explanation:

man’s mother husband = father
So the answer be man’s Brother

Question 2

Pointing to old man Kailash said “his son is my son’s uncle” How is kailash is related to old man.

- (a) Brother (b) Either son (or) son-in-law
(c) Father (d) Grand Father

Answer: B

Explanation:

So Kailash is related to old man is in terms of Father son relation.

Question 3

If A is the brother of B; B is the sister of C; and C is the father of D, how D is related to A?

- (a) Brother (b) Sister
(c) Nephew (d) Cannot be determined

Answer: D

Explanation:

If D is Male, the answer is Nephew. If D is Female, the answer is Niece. As the sex of D is not known, hence, the relation between D and A cannot be determined. Note: Niece - A daughter of one's brother or sister, or of one's brother-in-law or sister-in-law. Nephew - A son of one's brother or sister, or of one's brother-in-law or sister-in-law.

Question 4

A is the son of C; C and Q are sisters; Z is the mother of Q and P is the son of Z. Which of the following statements is true?

- (a) P and A are cousins (b) P is the maternal uncle of A
(c) Q is the maternal grandfather of A (d) C and P are sisters

Answer: B

Explanation:

C and Q are sisters and A is the son of C. Hence, C is the mother of A or Z is the mother Q. Hence, Z is the maternal grandmother of A. P is the son of Z. Hence, P is the maternal uncle of A.

NOV 2019

A, B, C, D, E and F are members of a family. B is the son of A DUE the mother of B, A and C are married couple. F is the brother of A. D is the sister of B, E is the son of C.

Question1

How many male members are there in the family.

- | | |
|-------|-------|
| (a) 1 | (b) 2 |
| (c) 3 | (d) 4 |

Q.2 How is F related to B?

- | | |
|-----------|--------------|
| (a) Uncle | (b) Daughter |
| (c) Son | (d) Niece |

Q.3 How many children A has?

- | | |
|-------|-------|
| (a) 3 | (b) 2 |
| (c) 4 | (d) 1 |

Answer:

For question [1-3]

(+) => male

(-) => female

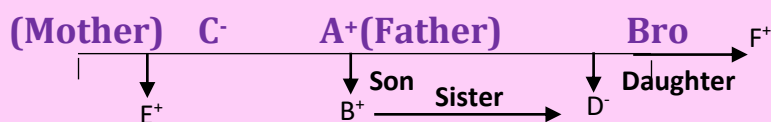

Q.1 (Ans.) (d) There are four male members in the family i.e.

A (father or husband)

F (A's brother)

B (son of A and C)

E (son of A and C)

Q.2 (Ans.) (a) Since F is A's brother and B is A's son. father's brother = uncle So, F is the uncle of B

Q.3 (Ans.) (a) A has 3 children E, B and D

DEC 2020

Question 1

Pointing towards a person a man said to a woman. "His mother is the only daughter of your father". How is the woman related to that person?

- (a) daughter (b) mother
(c) sister (d) wife

Answer: B

Explanation:

The only daughter of the woman's father is she herself. So, the person is the woman's son. i.e., the woman is the person's mother. Hence, the answer is (b).

Question 2

Vicky introduces John as the son of the only brother of his father's wife. How is Vicky related to John?

- (a) Cousin (b) Son
(c) Brother (d) Uncle

Answer: A

Explanation:

The only brother of his father's wife is Sohan's maternal uncle.

So, Mohan is Sohan's maternal uncle's son.

So, Mohan is Sohan's cousin.

Option A.

Question 3

Point out to a lady sohil said she is the daughter of woman. Who is the mother of the husband of my mother? Who is the lady to sohil?

- (a) Sister (b) Aunt
(c) Daughter (d) Sister-in-law

Answer: B

Explanation:

The relations may be analyzed as follows:

Mother's husband ⇒ Father;

Father's mother \Rightarrow Grandmother;
 Grandmother's daughter \Rightarrow Father's sister;
 Father's sister \Rightarrow Aunt.
 So, the lady is Rajan's aunt.
 Hence, the answer is (b).

IAN 2021

Question 1

P is the brother of Q and R, S is the mother of R. T is the father of P. which of the following statements cannot be definitely true?

- | | |
|--------------------------|--------------------|
| (a) S is the mother of P | (b) P is son of S |
| (c) T is husband of S | (d) Q is son of T. |

Answer: D

Explanation:

P, Q, R are children of same parents. So, S who is R's mother and T, who is R's father will be mother and father of all three. However, it is not mentioned whether Q is male or female So, D cannot be definitely true.

Question 2

Pointing to a lady in a photograph, Ran said, "her son's father is the son-in-law of my mother," how is Ram related to the lady?

- | | |
|------------|------------|
| (a) Aunt | (b) Cousin |
| (c) Sister | (d) Mother |

Answer: B

Explanation:

Ram is brother of that lady.

Question 3

A girl introduces a boy as the son of the daughter of the father of her uncle the boy is girl's

- | | |
|----------------|-------------|
| (a) Son | (b) Brother |
| (c) Son-in-law | (d) Uncle |

Answer: B

Explanation:

Daughter of uncle's father — Uncle's sister — Mother; Mother's son — Brother

Question 4

Pointing to lady, Sahil said "She is the daughter of the woman who is the mother of the husband of my mother, "who is the lady to Sahil?

- | | |
|--------------|-----------------------|
| (a) Aunt | (b) Sister |
| (c) Daughter | (d) Sister – in – law |

Answer: A

Explanation:

The relations may be analyzed as follows:

Mother's husband \Rightarrow Father;

Father's mother \Rightarrow Grandmother;

Grandmother's daughter \Rightarrow Father's sister;

Father's sister \Rightarrow Aunt.

So, the lady is Rajan's aunt. Hence, the answer is (a).

JULY 2021**Question 1**

Pointing towards "A", "B", said: "Your mother is younger sister of my mother". "A" is related to "B" as__

- (a) Uncle (b) Cousin
(c) Nephew (d) Father

Answer: Options (b)

Explanation:

Pointing towards A, B said "your mother is the younger sister of my mother"

We draw the flow chart of given information as follows, circle around the alphabet indicates that person is a lady

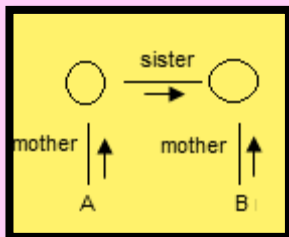

A is the cousin of B. So b is the answer

Question 2

Shyam's mother said to Shyam "my mother has a son whose son is Ram". Shyam is related to Ram as _

- (a) Uncle (b) Cousin
(c) Nephew (d) Grandfather

Answer: Options (b)

Question 3

Amit said "This girl is the wife of the grandson of my mother". How Amit related to the girl?

- (a) Father-in-law (b) Grandson
(c) Father (d) Son

Answer: Options (a)

Explanation:

The grand-son of Amit's mother mean his son.
So, the wife of his son is daughter-in-law to him.
Therefore, Amit is the father-in-law of the girl.

Question 4

**A is the son of C; C and Q are sisters: Z is the mother of Q and P is the son of Z.
Which of the following statements is true?**

- (a) A and P are cousins
(b) C and P are sisters
(c) P is the maternal uncle of A
(d) A is the maternal uncle of P

Answer: Options (c)**Explanation:**

C and Q are sisters and A is the son of C.
C is the mother of A and Z is the mother Q.
Hence, Z is the matemal grandmother of A.
P is the son of Z.
Hence, P is the material uncle of A.

DEC 2021**Question 1**

D is daughter of E. A is son of D. C is a brother of A and B is the sister of A. F is the brother of D. How F is related to B?

- (a) Father-in-law
(b) Brother
(c) Uncle
(d) Mother-in-law

Answer: c**Explanation:**

Let me be B. Since I'm the sister of A, A is my brother. Since A (my brother) is the son of D, D is my mother. Since F is the brother of D (my mother), F is my maternal uncle.

Question 2

Introducing a boy a girl said, "He is the son of the daughter of the father of my uncle". Who is the boy to the girl?

- (a) Brother
(b) Nephew
(c) Uncle
(d) Son-in-law

Answer: a**Explanation:**

Let me be the girl introducing the boy. If the uncle is paternal, then the father of my uncle would be my grandfather (Dadaji), and hence his daughter would be my aunt (Bua). Son of my Bua would be my cousin. However, cousin is not in is the options.

If the uncle is maternal, then the father of my uncle would be my grandfather (Nanaji),

and hence his daughter could either be my Mother, or my Aunt (Mausi). Again, if the daughter is my Aunt, then her son would be my cousin, and cousin is not in the options. If the daughter is my Mother, then her son would be my brother.

Therefore, option (a) is the answer.

Question 3

It is given that 'A is the mother of B; B is the sister of C; C is the father of D'. How is A related to D?

- | | |
|------------|-----------------|
| (a) Mother | (b) Grandmother |
| (c) Aunt | (d) Sister |

Answer: b

Explanation:

Let me be D. C is my father. B, my father's sister, is my Aunt. A, my aunt's mother, would be my Grandmother.

Question 4

R told to M as, "the girl, I met at the beach, was the youngest daughter of the brother-in-law of my friend's mother". How is the girl related to R's friend?

- | | |
|------------|--------------|
| (a) Cousin | (b) Daughter |
| (c) Niece | (d) Aunt |

Answer: a

Explanation:

Let me be R's friend. Now, my mother's brother-in-law would be either my paternal uncle, or my maternal aunt's husband. Either way, the daughter would be my cousin.

Question 5

P, Q, R, S, T, U are 6 members of a family in which there are two married couples. T, a teacher is married to a doctor who is mother of R and U. Q the lawyer is married to P. P has one son and one grandson. Of the two married ladies one is a housewife. There is also one student and one male engineer in the family. Which of the following is true about the granddaughter of the family?

- | | |
|----------------------|------------------------|
| (a) She is a lawyer | (b) She is an engineer |
| (c) She is a student | (d) She is a doctor |

Answer: c

Explanation:

The family tree is as follows:

Q is the male lawyer married to P who is a housewife. They have a son, T, who is a teacher. T is married to S, who is a doctor. They have two children - R and U. Out of them, one is a male engineer, and the other is a student.

Therefore, the granddaughter of the family is a student.

Question 6

X and Y are brothers. R is the father of Y. S is the brother of T and maternal uncle

of X. What is T to R?

- (a) Mother (b) Wife
(c) Sister (d) Brother

Answer: b

Explanation:

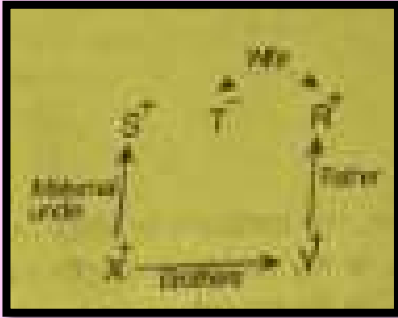

T is the wife of 'R'

JUNE 2022

Question 1

Ravi is son of Aman's father's sister. Ram is son of Divya. Who is the mother of Gourv and grandmother of Aman. Ashok is father of Tanya and grandfather of Ravi. Divya is wife of Ashok. How is Ravi related to Divya?

- (a) Nephew (b) Grandson
(c) Son (d) None

Answer: Options (b)

Explanation:

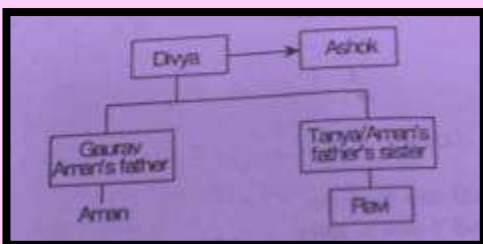

Ravi is the grandson of Divya.

Question 2

$P + Q$ means P is brother of Q, $P - Q$ means P is the mother of Q, $P \times Q$ means P is the sister of Q. Which of the following means M is the maternal uncle of R?

- (a) $M + K + R$ (b) $M - R + K$
(c) $M + K - R$ (d) $M + K \times R$

Answer: Options (c)

Explanation:

$P + Q$ means 'P' is the brother of 'Q'

$P - Q$ means 'P' is the mother of 'Q' $P \times Q$ means 'P' is the sister of Q

M + K – R

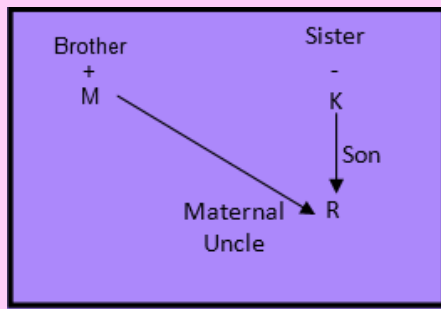

M is the Maternal uncle if R

Question 3

A woman going with a boy is asked by another woman about the relationship between them, The woman replied “ My maternal uncle and the uncle are his maternal uncle are same”, the relationship between the lady and the boy is _

- (a) Maternal grandmother and grandson (b) Mother and son
(c) Father and son (d) Paternal grandmother and grandson

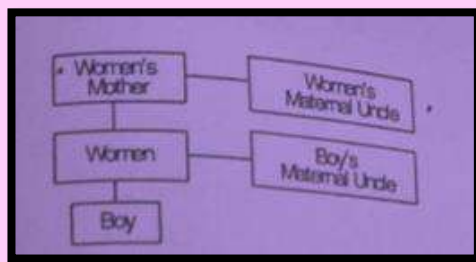
Answer: Options (b)**Explanation:**

The Relationship b/w the lady and the boy is mother and son

Question 4

If Kamal says, “Ravi’s mother is the only daughter of my mother. How is Kamal related to Ravi?”

- (a) Father (b) Grandmother
(c) Son (d) Maternal uncle

Answer: Options (d)**Explanation:**

Only daughter of Komal’s mother – Komal’s sister

So, Ravi’s mother is komal’s sister or Komal is the brother of Ravi’s mother i.e. Komal is Ravi’s Maternal Uncle

Question 5

A is B’s sister. C is B’s mother. D is C’s father. E is D’s mother. Then how A is related to D?

- (a) Grandfather (b) Grandmother
(c) Daughter (d) Grand daughter

Answer: Options (a)

Explanation:

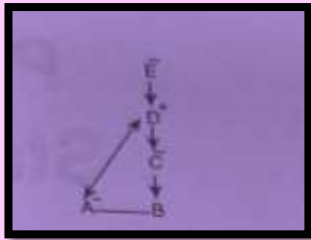

∴ D is the father of C and D is the grandfather of A.

Question 6

If A \$ B means A is father of B. A # B means A is daughter of B. A @ B means A is sister of B. Then how is K related to M H @ K \$ L # M

- (a) Husband (b) Uncle
(c) Father (d) Grandson

Answer: Options (a)

Explanation:

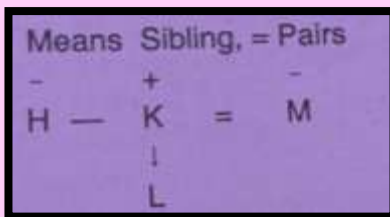

K is the husband of M

DEC 2022

Question 1

Suresh's sister is the wife of Ram. Ram is Rani's brother, Ram's father is Madhur Sheetal is Ram's grandmother. Rema is sheetal's daughter - in - law. Rohit is Rani's brother's son. Who is Rohit to Suresh?

- a) Brother-in-law (b) Son
c) Brother (d) Nephew

Answer: Options (d)

Explanation:

→ Ram is brother of Rani Rohit is son of Ram suresh is maternal uncle of Rohit Therefore, Rohit is nephew of Suresh So, the answer is (d)

Question 2

There are six children playing football namely A, B, C, D, E, and F, A, & E are brothers. F is sister of E. C is the only son of A's uncle. B & D are daughters of the

brother of C's father. How D is related to A?

- | | |
|----------|-----------|
| a) Uncle | b) Cousin |
| c) Niece | d) Sister |

Answer: Options (b)

Explanation:

Clearly, D's father is the brother of C's father and C's father is A's Uncle. So, D's father is also A's Uncle. Thus, D is A's cousin.

Question 3

In a joint family, there are father, mother, 3 married sons and one unmarried daughter. Out of the sons, two have 2 daughters each and one has a son only. How many female members are there in the family?

- | | |
|------|------|
| a) 3 | b) 6 |
| c) 9 | d) 5 |

Answer: Options (c)

Explanation:

Female members: Mother, 3 daughters-in-law, one daughter. Four grand daughters
Thus, there are nine female members.

Question 4

When Rani saw Vinit, she recollected that "He is the brother of My grandfather's son." How is Rani related to Vinit?

- | | |
|-----------|-------------|
| a) Aunt | b) Daughter |
| c) Sister | d) Niece |

Answer: Options (d)

Explanation:

Grandfather's son can be Father or uncle so his brother is uncle of Rani
Hence, Rani is niece of Vinit.

Question 5

Annanya is mother of Satya and Shyam is the son of Bhima. Shiva is brother of Annanya. If Satya is sister of Shyam, how Bhima is related to Shiva?

- | | |
|-------------------|---------------|
| a) Son | b) Cousin |
| c) Brother-in-law | d) Son-in-law |

Answer: Options (c)

Explanation:

Below table shows symbols and their description,

Symbol in Diagram	Meaning
○	Female
□	Male
— —	Married Couple
—	Siblings
	Difference of A Generation

1) Ananya is the mother of Satya and Shyam is the son of Bhima.



2) Shiva is the brother of Ananya.



3) If Satya is the sister of Shyam, Ananya is the spouse of Bhima.

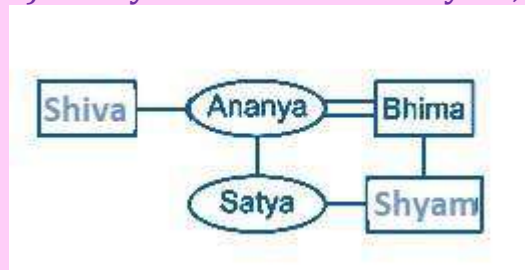

Thus Bhima is Shiva's brother in law.

Question 6

Suman is daughter-in-law of Rakesh and sister-in-law of Rajesh. Ramesh is the son of Rakesh and only brother of Rajesh. Find the relation of Suman with Ramesh.

- | | |
|------------------|-----------|
| a) Sister-in-law | b) Cousin |
| c) Aunt | d) Wife |

Answer: Options (d)

Explanation:

Rakesh is Father

Suman – Daughter in law

Rajesh – brother of ramesh and children if rakesh
Ramesh – Husband of Suman
Hence, Suman is wife of Ramesh.

Question 7

Pointing to a man in photograph, Khushi says, “This man’s son’s sister is my mother-in-law.” How is the Khushi’s husband related to the man in the photograph?

- | | |
|---------------|-----------|
| a) Grandson | b) Son |
| c) Son in law | d) Cousin |

Answer: Options (a)

Explanation:

Man's son's sister is man's daughter. So, the man's daughter is the mother of the woman's husband. Thus, the woman's husband is the grandson of the man in the photograph.

CHAPTER - 13 STATISTICAL DESCRIPTION OF DATA

COLLECTION OF DATA

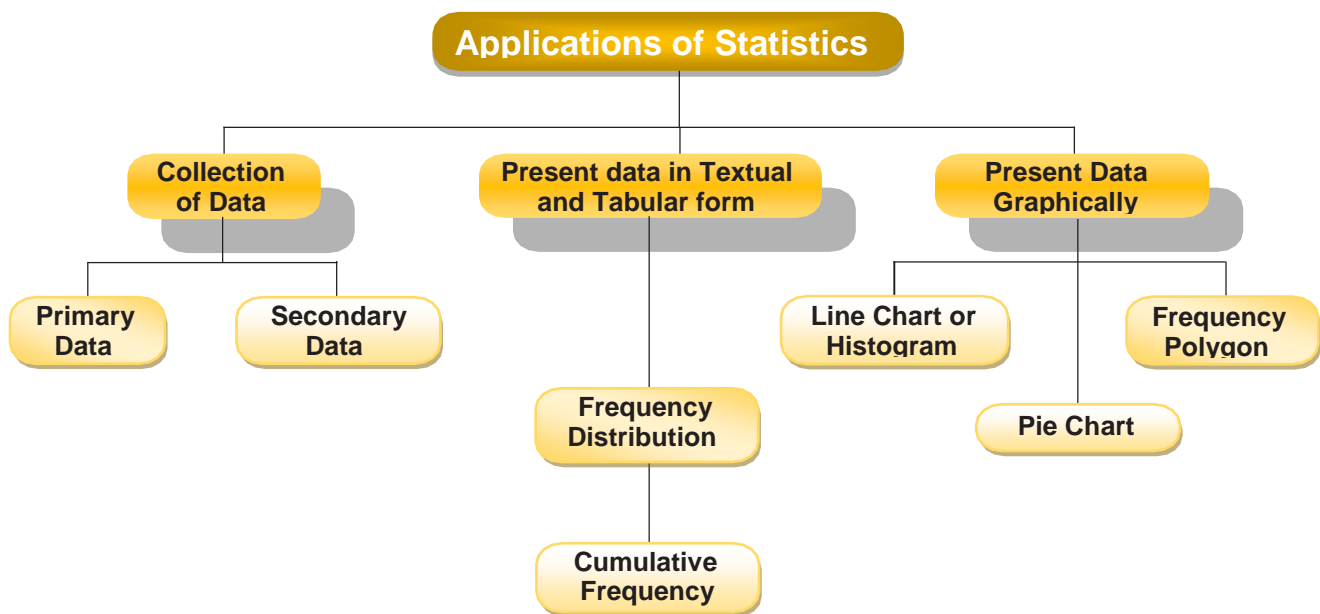

Primary method

- Interview
- Mailed questionnaire
- Observation
- Questionnaires filled and sent by enumerators.

Secondary method

- International sources
- Unpublished sources of various research institutes, researchers
- Government sources
- Private and quasi-government sources

PRESENTATION OF DATA	Classification or Organization of Data	The process of arranging data on the basis of the characteristic under consideration into a number of groups or classes according to the similarities of the observations.
	Data may be classified as	(i) Chronological or Temporal or Time Series Data; (ii) Geographical or Spatial Series Data; (iii) Qualitative or Ordinal Data; (iv) Quantitative or Cardinal Data.
	Mode of Presentation of Data	(a) Textual presentation (b) Tabular presentation or Tabulation (c) Diagrammatic representation I. Line diagram or Histogram II. Bar diagram III. Pie chart
FREQUENCY DISTRIBUTION	tabular representation of statistical data, usually in an ascending order, relating to a measurable characteristic according to individual value or a group of values of the characteristic under study	
CLASS LIMIT (CL)	Corresponding to a class interval, the class limits may be defined as the minimum value and the maximum value the class interval may contain.	
CLASS BOUNDARY (CB)	Class boundaries may be defined as the actual class limit of a class interval $LCB = LCL - \frac{D}{2}$	
MID-POINT OR MID-VALUE OR CLASS MARK	Corresponding to a class interval, this may be defined as the total of the two class limits or class boundaries to be divided by 2. Thus, we have $\text{mid-point} = \frac{LCL + UCL}{2}$	
CUMULATIVE FREQUENCY	The cumulative frequency corresponding to a value for a discrete variable and corresponding to a class boundary for a continuous variable may be defined as the number of observations less than the value or less than or equal to the class boundary.	
GRAPHICAL REPRESENTATION	•Histogram or Area diagram: A histogram is an accurate representation of the distribution of numerical data. It is an estimate of the probability	

<p>OF A FREQUENCY DISTRIBUTION</p>	<p>distribution of a continuous variable (quantitative variable) and was first introduced by Karl Pearson.</p> <ul style="list-style-type: none"> •Frequency Polygon: Frequency polygons are a graphical device for understanding the shapes of distributions. They serve the same purpose as histograms, but are especially helpful for comparing sets of data. Frequency polygons are also a good choice for displaying cumulative frequency distributions. •Ogives or Cumulative Frequency Graph: Cumulative histograms, also known as ogives, are graphs that can be used to determine how many data values lie above or below a particular value in a data set. The cumulative frequency is calculated from a frequency table, by adding each frequency to the total of the frequencies of all data values before it in the data set.
<p>FREQUENCY CURVE</p>	<p>A frequency curve is a smooth curve for which the total area is taken to be unity. It is a limiting form of a histogram or frequency polygon.</p> <p>Types of frequency curves namely:</p> <ol style="list-style-type: none"> Bell-shaped curve U-shaped curve J-shaped curve Mixed curve.
<p>STATISTICS</p>	<p>The term statistics is ultimately derived from the New Latin <i>statisticum collegium</i> ("council of state") and the Italian word <i>statista</i> ("statesman" or "politician"). ... Thus, the original principal purpose of <i>Statistik</i> was data to be used by governmental and (often centralized) administrative bodies.</p>



Question 1

What percentage of candidates passed the exam from Institute T out of the total number of candidates enrolled from the same institute?

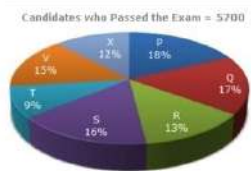

- (a) 50% (b) 62.5%
 (c) 75% (d) 80%

Answer: C

Explanation:

$$\text{Required percentage} = \left\langle \frac{9\% \text{ of } 5700}{8\% \text{ of } 8550} \times 100 \right\rangle \% = \left\langle \frac{9 \times 5700}{8\% \text{ of } 8550} \times 100 \right\rangle \% = 75\%.$$

Question 2

Which institute has the highest percentage of candidates passed to the candidates enrolled?

- (a) Q (b) R
 (c) V (d) T

Answer: B

Explanation:

The percentage of candidates passed to candidates enrolled can be determined for each institute as under:

$$(i) P = \left[\left(\frac{18\% \text{ OF } 5700}{22\% \text{ OF } 8550} \right) \times 100 \right] \% = \left[\frac{18 \times 5700}{22 \times 8550} \times 100 \right] \% = 54.55\%$$

$$(ii) Q = \left[\left(\frac{17\% \text{ OF } 5700}{15\% \text{ OF } 8550} \right) \times 100 \right] \% = 75.56\%$$

$$(iii) R = \left[\left(\frac{13\% \text{ OF } 5700}{10\% \text{ OF } 8550} \right) \times 100 \right] \% = 86.67\%$$

$$(iv) S = \left[\left(\frac{16\% \text{ OF } 5700}{17\% \text{ OF } 8550} \right) \times 100 \right] \% = 62.75\%$$

$$(v) T = \left[\left(\frac{9\% \text{ OF } 5700}{8\% \text{ OF } 8550} \right) \times 100 \right] \% = 75\%$$

$$(vi) V = \left[\left(\frac{15\% \text{ OF } 5700}{12\% \text{ OF } 8550} \right) \times 100 \right] \% = 83.33\%$$

$$(vii) X = \left[\left(\frac{12\% \text{ OF } 5700}{16\% \text{ OF } 8550} \right) \times 100 \right] \% = 50\%$$

Highest of these is 86.67% corresponding to institute R.

Question 3

The number of candidates passed from institutes S and P together exceeds the number of candidates enrolled from institutes T and R together by:

- (a) 288 (b) 279
(c) 399 (d) 407

Answer: C

Explanation:

$$\begin{aligned}\text{Required difference} &= [(16\% + 18\%) \text{ of } 5700] - [(8\% + 10\%) \text{ of } 8550] \\ &= [(34\% \text{ of } 5700) - (18\% \text{ of } 8550)] \\ &= (1938 - 1539) \\ &= 399.\end{aligned}$$

Question 4

What is the percentage of candidates passed to the candidates enrolled for institutes Q and R together?

- (a) 68% (b) 80%
(c) 74% (d) 65%

Answer: b

Explanation:

Candidates passed from institute Q

$$\begin{aligned}\text{And R together} &= [(13\% + 17\%) \text{ of } 5700] \\ &= 30\% \text{ of } 5700.\end{aligned}$$

$$\begin{aligned}\text{Candidates enrolled from institute Q at} &= [(15\% + 10\%) \text{ of } 8550] \\ &= 25\% \text{ of } 8550.\end{aligned}$$

∴ Required

$$\text{Percentage} = \left(\frac{30\% \text{ of } 5700}{25\% \text{ of } 8550} \times 100 \right) \%$$

$$= \left(\frac{30 \times 5700}{25 \times 8550} \times 100 \right) \%$$

$$= 80\%$$

Question 5

What is the ratio of candidates passed to the candidates enrolled from institute P?

- (a) 9: 11 (b) 14: 17
(c) 6: 11 (d) 9: 17

Answer: C

Explanation:

$$\text{Required ratio} = \left(\frac{18\% \text{ of } 5700}{22\% \text{ of } 8550} \right) = \left(\frac{18 \times 5700}{22 \times 8550} \right) = \frac{6}{11}$$

Question 6

A sum of Rs. 4.75 lakhs were invested in Company Q in 1999 for one year. How much more interest would have been earned if the sum was invested in company P?

- (a) Rs. 19,000 (b) Rs. 14, 250
(c) Rs. 11,750 (d) Rs. 9500

Answer: D

Explanation:

Difference

$$= \text{Rs. } [(10\% \text{ of } 4.75) - (8\% \text{ of } 4.75) \text{ lakhs}]$$

$$= \text{Rs. } (2\% \text{ of } 4.75) \text{ lakhs}$$

$$= \text{Rs. } 0.095 \text{ lakhs}$$

$$= \text{Rs. } 9500$$

Question 7

If two different amounts in the ratio 8:9 are invested in company's P and Q respectively in 2002, then the amounts received after one year as interests from company's P and Q are respectively in the ratio?

- (a) 2:3 (b) 3:4
(c) 6:7 (d) 4:3

Answer: D

Explanation:

Let the amounts invested in 2002 in Companies P and Q be Rs. $8x$ and Rs. $9x$ respectively.

Then, interest received after one year from company P = Rs. $(6\% \text{ of } 8x) = \text{Rs. } \frac{48x}{100}$.

And interest received after one year from company Q = Rs. $(4\% \text{ of } 9x) = \text{Rs. } \frac{36x}{100}$

$$\therefore \text{Required ratio} = \frac{\left(\frac{48x}{100}\right)}{\left(\frac{36x}{100}\right)} = \frac{4}{3}$$

Question 8

In 2000, a part of Rs. 30 lakhs was invested in company P and the rest was invested in company Q for one year. The total interest received was Rs. 2.43 lakhs. What was the amount invested in company P?

- (a) Rs. 9 lakhs (b) Rs. 11 lakhs
(c) Rs. 12 lakhs (d) Rs. 18 lakhs

Answer: D

Explanation:

Let Rs. x lakhs be invested in company P in 2000, the amount invested in company Q in 2000 = Rs. $(30 - x)$ lakhs.

Total interest received from the two companies after 1 year

= Rs. $[(7.5\% \text{ of } x) + \{9\% \text{ of } (30 - x)\}]$ lakhs

= $\left[\text{Rs. } 2.7 - \left(\frac{1.5x}{100}\right) \text{ lakhs} \right]$

$$\therefore \left[2.7 - \left(\frac{1.5x}{100}\right) \right] = 2.43 \quad \Rightarrow \quad x = 18$$

Question 9

An investor invested a sum of Rs. 12 lakhs in company P in 1998. The total amount received after one year was re-Invested in the same company for one more year. The total appreciation received by the investor on his investment was?

- (a) Rs. 2, 96,200 (b) Rs. 2, 42,200
(c) Rs. 2, 25, 600 (d) None

Answer: C

Explanation:

Amount received from Company P after one year (i.e., in 1999) on investing Rs. 12 lakhs in it.

= Rs. $[12 + (8\% \text{ of } 12)]$ lakhs

= Rs. 12.96 lakhs

Amount received from company P after one year on investing Rs. 12.96 lakhs in the year 1999

= Rs. $[12.96 + \{10\% \text{ of } 12.96\}]$ lakhs

= Rs. 14.256

Appreciation received on investment during the period of two years

= Rs. $(14.256 - 12)$ lakhs

= Rs. 2.256 lakhs

= Rs. 2, 25,600.

Question 10

An investor invested Rs. 5 lakhs in company Q in 1996. After one year, the entire amount along with the interest was transferred as investment to Company P in 1997 for one year. What amount will be received from Company P, by the investor?

- (a) Rs. 5,94,550 (b) Rs. 5, 80,425
(c) Rs. 5,77,800 (d) Rs. 5,77,500

Answer: B

Explanation:

Amount received from Company Q after one year on investment of Rs. 5 lakhs in the year 1996

= Rs. [5 + (6.5% of 5)] lakhs

= Rs. 5.325 lakhs.

Amount received from company P after one year on investment of Rs. 5.325 lakhs in the year 1997.

= Rs.[5.325 + (9% of 5.325)] lakhs

= Rs. 5.80425 lakhs

= Rs. 5, 80,425.

Direction (for Q. Nos. 11 – 15):

The following table gives the sales of batteries manufactured by a company over the years.

Number of Different Types of Batteries Sold by a Company Over the Years (Numbers in Thousands)

Year	Types of Batteries					Total
	4AH	7AH	32AH	35AH	55AH	
1992	75	144	114	102	108	543
1993	90	126	102	84	126	528
1994	96	114	75	105	135	525
1995	105	90	150	90	75	510
1996	90	75	135	75	90	465
1997	105	60	165	45	120	495
1998	115	85	160	100	145	605

Question 11

What was the approximate percentage increase in the sales of 55AH batteries in 1998 compared to that in 1992?

- (a) 28% (b) 31%
(c) 33% (d) 34%

Answer: D

Explanation:

$$\begin{aligned} \text{Required percentage} &= \left[\frac{(145-108)}{108} \times 100 \right] \% \\ &= 34.26\% \\ &= 34\% \end{aligned}$$

Question 12

The total sales of all seven years in the maximum for the maximum for which battery?

- (a) 4AH (b) 7AH
(c) 32AH (d) 35AH

Answer: C

Explanation:

The total sales (in thousands) of all the seven years for various batteries are:

For 4AH = 75 + 90 + 96 + 105 + 90 + 105 + 115 = 676

For 7AH = 144 + 126 + 114 + 90 + 75 + 60 + 85 = 694

For 32AH = 114 + 102 + 75 + 150 + 135 + 165 + 160 = 901

For 35AH = 102 + 84 + 105 + 90 + 75 + 45 + 100 = 601

For 55AH = 108 + 126 + 135 + 75 + 90 + 120 + 145 = 799.

Clearly sales are maximum in case of 32AH batteries.

Question 13

What is the difference in the number of 35AH batteries sold in 1993 and 1997?

- (a) 24000 (b) 28000
(c) 35000 (d) 39000

Answer: D

Explanation:

Required difference = $[(84 - 45) \times 1000] = 39000$.

Question 14

The percentage of 4AH batteries sold to the total number of batteries sold was maximum in the years?

- (a) 1994 (b) 1995
(c) 1996 (d) 1997

Answer: D

Explanation:

The percentage of sales of 4AH batteries to the total sales in different years are;

for 1992 = $\left(\frac{75}{543} \times 100\right)\% = 13.81\%$

for 1993 = $\left(\frac{90}{528} \times 100\right)\% = 17.05\%$

for 1994 = $\left(\frac{96}{525} \times 100\right)\% = 18.29\%$

for 1995 = $\left(\frac{105}{510} \times 100\right)\% = 20.59\%$

for 1996 = $\left(\frac{96}{465} \times 100\right)\% = 19.35\%$

for 1997 = $\left(\frac{105}{495} \times 100\right)\% = 21.21\%$

for 1998 = $\left(\frac{105}{605} \times 100\right)\% = 19.01\%$

Clearly the percentage in maximum in 1997

Question 15

In case of which battery there was a continuous decrease in sales from 1992 to 1997?

- (a) 4AH (b) 7AH
(c) 32AH (d) 35AH

Answer: B

Explanation:

From the table it is clear that the sales of 7AH batteries have been decreasing continuously from 1992 to 1997.

Direction (for Q. Nos. 16-20):

The bar graph given below shows the percentage distribution of the total production of a car manufacturing company into various models over two years.

Percentage of Six different types of Cars manufactured by a Company over Two Years

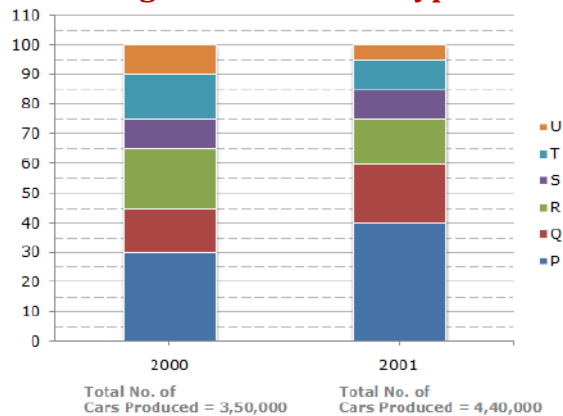

Question 16

What was the difference in the number of Q type cars product in 2000 and that produce in 2001?

- (a) 35,500 (b) 27,000
(c) 22,500 (d) 17,500

Answer: A

Explanation:

Total numbers of Q type cars produced in 2001

$$= (60 - 40) \% \text{ of } 4,40,000 = 88,000.$$

Total numbers of Q type cars produced in 2000

$$= (45 - 30) \% \text{ of } 3,50,000 = 52,500.$$

$$\therefore \text{ Required difference} = (88000 - 52500) = 35,500.$$

Question 17

Total number of cars of models P, Q and T manufactured in 2000 is?

- (a) 2,45,000 (b) 2,27,500
(c) 2,10,000 (d) 1,92,500

Answer: C

Explanation:

Analysis of the graph:

We shall first determine the number of cars of each model produced by the company during the two years:

In 2000: Total number of cars produced = 3,50,000

$$P = (30 - 0) \% \text{ OF } 3,50,000 = 30\% \text{ OF } 3,50,000 = 1,05,000.$$

$$Q = (45 - 30) \% \text{ OF } 3,50,000 = 15\% \text{ OF } 3,50,000 = 52,500.$$

$$R = (65 - 45) \% \text{ OF } 3,50,000 = 20\% \text{ OF } 3,50,000 = 70,000$$

$$S = (75 - 65) \% \text{ OF } 3,50,000 = 10\% \text{ OF } 3,50,000 = 35,000$$

$$T = (90 - 75) \% \text{ OF } 3,50,000 = 15\% \text{ OF } 3,50,000 = 52,500$$

$$U = (100 - 90) \% \text{ OF } 3,50,000 = 10\% \text{ OF } 3,50,000 = 35,000$$

In 2001: Total number of cars produced = 4, 40,000.

$$P = (40 - 0) \% \text{ OF } 4, 40,000 = 40\% \text{ OF } 4, 40,000 = 1, 76,000.$$

$$Q = (60 - 40) \% \text{ OF } 4, 40,000 = 20\% \text{ OF } 4, 40,000 = 88, 000$$

$$R = (75 - 60) \% \text{ OF } 4, 40,000 = 15\% \text{ OF } 4, 40,000 = 66, 000$$

$$S = (85 - 75) \% \text{ OF } 4, 40,000 = 10\% \text{ OF } 4, 40,000 = 44, 000$$

$$T = (75 + 60) \% \text{ OF } 4, 40,000 = 10\% \text{ OF } 4, 40,000 = 44, 000.$$

$$U = (100 - 95) \% \text{ OF } 4, 40,000 = 5\% \text{ OF } 4, 40,000 = 22, 000$$

Total number of cars of models P, Q, and T manufacturing in 2000

$$= (105000 + 52500 + 52500)$$

$$= 2, 10,000.$$

Question 18

If the percentage production of P type cars in 2001 was the same as that in 2000, then the number of P type cars produced in 2001 would have been?

(a) 1,40,000

(b) 1,32,000

(c) 1,17,000

(d) 1,05,000

Answer: B

Explanation:

If the percentage production of P type in cars in 2001

$$= \text{Percentage production of P type cars in 2000}$$

$$= 30\%$$

Then, number of P type cars produced in 2001

$$= 30\% \text{ of } 4, 40,000$$

$$= 1, 32,000.$$

Question 19

If 85% of the cars produced in each year were sold by the company, how many S type cars remain unsold?

(a) 7650

(b) 9350

(c) 11,850

(d) 12,250

Answer: C

Explanation:

Number of S type cars which remained unsold in 2000 = 15% of 35,000

And number of S type cars which remained unsold in 2001 = 15% of 44, 00.

∴ Total number of S type cars which remained unsold

$$= 15\% \text{ of } (35,000 + 44,000)$$

$$= 15\% \text{ of } 79,000$$

$$= 11,850$$

Question 20

For which model the percentage rise/fall in production from 2000 to 2001 was minimum?

(a) Q

(b) R

(c) S

(d) T

Answer: B

Explanation:

The percentage change (rise/fall) in production from 2000 to 2001 for various models is:

$$\text{For P} = \left[\frac{(176000 - 105000)}{105000} \times 100 \right] \% = 67.62\% \text{ rise.}$$

$$\text{For Q} = \left[\frac{(88000 - 52500)}{52500} \times 100 \right] \% = 67.62\% \text{ rise.}$$

$$\text{For R} = \left[\frac{(70000 - 66000)}{70000} \times 100 \right] \% = 5.71\% \text{ fail.}$$

$$\text{For S} = \left[\frac{(44000 - 35000)}{35000} \times 100 \right] \% = 25.71\% \text{ rise.}$$

$$\text{For T} = \left[\frac{(52500 - 44000)}{52500} \times 100 \right] \% = 16.19\% \text{ fail.}$$

$$\text{For U} = \left[\frac{(35000 - 22000)}{35000} \times 100 \right] \% = 37.14\% \text{ fail.}$$

∴ Minimum percentage rise/fail is production is the cash of model R.

Direction (for Q.Nos. 21 - 24):

Study the following graph and tables and answer the questions given below.
Distribution of candidates who were enrolled for MBA entrance exam and the candidates (out of those enrolled) who passed the exam in different institutes:



Question 21

What will be the percentage of total number of males in U.P., M.P. and Goa together to the total population of all the given states?

- (a) 25% (b) 27.5%
(c) 38.5% (d) 31.5%

Answer: C

Explanation:

$$\text{Number of males in U.P.} = \left[\frac{3}{5} \text{ of } (15\% \text{ OF } N) \right] = \frac{3}{5} \times \frac{15}{100} \times N = 9 \times \frac{N}{100}$$

Where $N = 3276000$.

$$\text{Number of males in M.P.} = \left[\frac{3}{4} \text{ of } (20\% \text{ OF } N) \right] = \frac{3}{4} \times \frac{20}{100} \times N = 15 \times \frac{N}{100}$$

$$\text{Number of males in Goa} = \left[\frac{3}{8} \text{ of } (12\% \text{ OF } N) \right] = \frac{3}{8} \times \frac{12}{100} \times N = 4.5 \times \frac{N}{100}$$

$$\therefore \text{Total numbers of males in these three states} = (9 + 15 + 4.5) \times \frac{N}{100}$$

$$= \left(28.5 \times \frac{N}{100}\right).$$

$$\therefore \text{Required Percentage} = \left[\frac{\left(28.5 \times \frac{N}{100}\right)}{N} \times 100 \right] \% = 28.5\%$$

Question 22**What was the total number of illiterate people in A.P. and M.P. in 1998?**

- (a) 876040 (b) 932170
(c) 981550 (d) 1161160

Answer: D**Explanation:**No. of illiterate people in A.P. = $\left[\frac{7}{9} \text{ of } (25\% \text{ of } 3276000) \right] = 637000.$ No. of illiterate people in M.P. = $\left[\frac{4}{5} \text{ of } (20\% \text{ of } 3276000) \right] = 524160.$ \therefore Total number = (637000 + 524160) = 1161160.**Question 23****What was the number of males in U.P. in the year 1998?**

- (a) 254650 (b) 294840
(c) 321470 (d) 341200

Answer: B**Explanation:**Number of males in U.P. = $\left[\frac{3}{5} \text{ of } (15\% \text{ of } 3276000) \right]$

$$= \frac{3}{5} \times \frac{15}{100} \times 3276000$$

$$= 294840$$

Question 24**If in the year 1998, there was an increase of 10% in the population of U.P. and 12% in the population of M.P. compared to the previous year, then what was the ratio of populations of U.P. and M.P. in 1997?**

- (a) 42:55 (b) 48: 55
(c) 7:11 (d) 4: 5

Answer: A**Explanation:**

Let x be the population of U.P. in 1997. Then,

Population of U.P. in 1998 = 110% of x = $\frac{110}{100} \times x.$

Also, Let y be the population of M.P. in 1997. Then,

Population of M.P. in 1998 = 112% of y = $\frac{112}{100} \times y.$ Ratio of population of U.P. and M.P. IN 1998 = $\left(\frac{\frac{110}{100} \times x}{\frac{112}{100} \times y} \right) = \frac{110x}{112y}$ From the pie-chart, this ratio is $\frac{15}{20}$

$$\frac{110x}{112y} = \frac{15}{20} \rightarrow \frac{x}{y} = \frac{15}{20} \times \frac{112}{110} = \frac{42}{55}$$

Thus, ratio of populations of U.P. and M.P. in 1997 = x : y = 42 : 55

Direction (for Q. Nos. 25 – 29):

A cosmetic company provides five different products. The sale of these five products (in lakh number of packs) during 1995 and 2000 are shown in the following bar graph
Sales (in lakh number of packs) of five different products of cosmetic company during 1995 and 2000

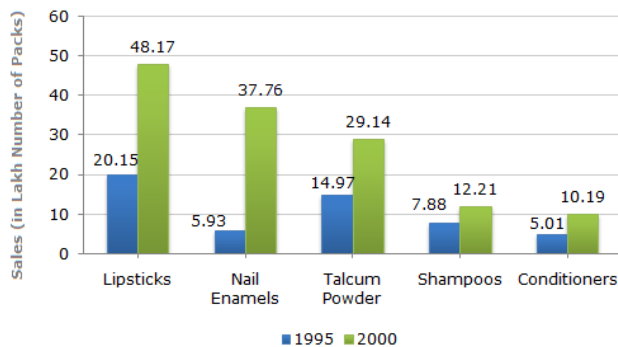

Question 25

Enamels in 2000? (Rounded off to nearest integer)

- (a) 33% (b) 31%
 (c) 28% (d) 22%

Answer: C

Explanation:

$$\begin{aligned} \text{Required percentage} &= \left[\frac{(48.17 - 37.76)}{37.76} \times 100 \% \right] \\ &= 27.57\% \\ &= 28\% \end{aligned}$$

Question 26

During the period 1995-2000, the minimum rate of increase in sales is in the case of?

- (a) Shampoos (b) Nail enamels
 (c) Talcum powders (d) Lipstick

Answer: A

Explanation:

The percentage increase from 1995 to 2000 for various products is

$$\text{Lipsticks} = \left[\frac{(48.17 - 20.15)}{20.15} \times 100 \right] \% = 139.06\%$$

$$\text{Nail enamels} = \left[\frac{(37.76 - 5.93)}{5.93} \times 100 \right] \% = 536.76\%$$

$$\text{Talcum powder} = \left[\frac{(29.14 - 14.97)}{14.97} \times 100 \right] \% = 94.66\%$$

$$\text{Shampoos} = \left[\frac{(12.21 - 7.88)}{7.88} \times 100 \right] \% = 54.95\% = 55\%$$

$$\text{Conditions} = \left[\frac{(10.19 - 5.01)}{5.01} \times 100 \right] \% = 103.39\%$$

∴ The minimum rate of increase in sales from 1995 to 2000 is in the case of shampoos.

Question 27

What is the approximate ratio of the sales of nail enamels in 2000 to the sales of Talcum powder in 1995?

- (a) 7:2 (b) 5:2
(c) 4:3 (d) 2:1

Answer: B

Explanation:

$$\text{Required ratio} = \frac{37.76}{14.97} = 2.5 = \frac{5}{2}$$

Question 28

The sales have increased by nearly 55% from 1995 to 2000 in the case of?

- (a) Lipstick (b) Nail enamels
(c) Talcum powders (d) Shampoos

Answer: D

Explanation:

The percentage increase from 1995 to 2000 for various products is:

$$\text{Lipstick} = \left[\frac{(48.17 - 20.15)}{20.15} \times 100 \right] \% = 139.06\%$$

$$\text{Nail enamels} = \left[\frac{(37.76 - 5.93)}{5.93} \times 100 \right] \% = 536.76\%$$

$$\text{Talcum powders} = \left[\frac{(29.14 - 14.97)}{14.97} \times 100 \right] \% = 94.66\%$$

$$\text{Shampoos} = \left[\frac{(12.21 - 7.88)}{7.88} \times 100 \right] \% = 54.95\% = 55\%$$

$$\text{Conditioners} = \left[\frac{(10.19 - 5.01)}{5.01} \times 100 \right] \% = 103.39\%$$

Question 29

The sales of conditioners in 1995 was by what percent less than the sales of shampoos in 1995? (Rounded off to nearest integer)

- (a) 57% (b) 36%
(c) 29% (d) 25%

Answer: B

Explanation:

$$\begin{aligned} \text{Required percentage} &= \left[\frac{(7.88 - 5.01)}{7.88} \times 100 \right] \% \\ &= 36.42\% \\ &= 36\%. \end{aligned}$$

Question 30

Following are the weights in kgs. Of 36BBA students of khalsa college.

70	73	49	61	47	57	50	59
59	68	45	55	68	56	68	55
70	70	57	44	73	64	49	63
65	70	65	62	73	67	60	50

Find range from this series

- (a) 6 (b) 5

(c) 7

(d) 9

Answer: A**Explanation:**

We have, range = Maximum weight - Minimum weight
 = 73 kgs - 44kgs.
 = 29 kgs.

No. of class interval \times class lengths = Range

$$\text{No. of class interval} \times 5 = 29$$

$$\text{No. of class interval} = \frac{29}{5} = 6.$$

(We always take the next integer as the number of class intervals so as to include both the minimum and maximum values).

Question 31**Which of the following statements is false?**

- (a) Statistics is derived from the Latin word 'status' (b) Statistics is derived from the Italian word 'Statista'
 (c) Statistics is derived from the French word 'Statistic' (d) None of these

Answer: C**Explanation:**

The term statistics is ultimately derived from the new Latin statisticum collegium ("council of state") and the Italian word Statista ("statesman" or "politician") Thus, the original principal purpose of statistic was data to be used by governmental and (often centralized) administrative bodies

Question 32

The given histogram shows a frequency distribution of marks obtained by 56 students in a subject.

Number of students securing marks between 70 and 100 is:

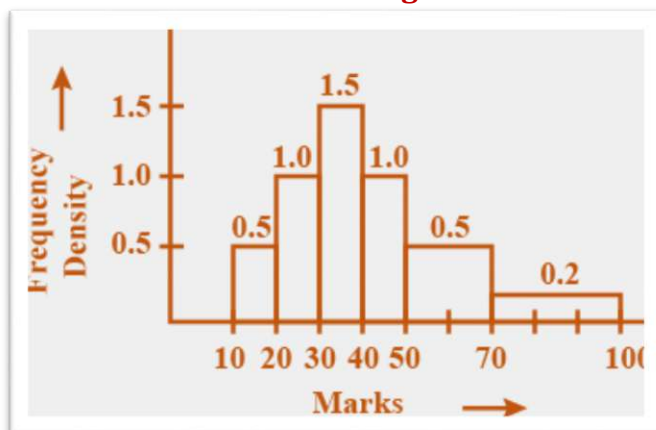

(a) 2

(b) 4

(c) 6

(d) 8

Answer: C**Explanation:**

Correct option is C

→ Class width between 70 to 100 = 0.2

We know, frequency density = $\frac{\text{Frequency}}{\text{Class width}}$

→ Frequency = Frequency density \times class width

→ Frequency = $0.2 \times 30 = 6$

∴ Number of students securing marks between 70 and 100 = 6

Question 33

The numbers of times a particular observation occurs in a given data is called its ____.

Fill in the blanks to make statements true.

- (a) Range (b) Interval
(c) Raw data (d) Frequency

Answer: D

Explanation:

Frequency of a value (observations) is defined by the number of times the value occurs in a given data set.

For example: 3, 3, 5, 5, 6, 7, 7, 7, 7, 7

In the above data set –

3 occurs 2 times, then 2 is the frequency of 3

5 occurs 3 times, then 3 is the frequency of 5

6 occurs 1 time, then 1 is the frequency of 6

7 occurs 4 times, then 4 is the frequency of 7

Therefore, the number of times a particular observation occurs in a given data set is called its frequency.

Question 34

Which of the following is calculated using mid-values of classes?

- (a) Mean (b) Median
(c) Mode (d) Range

Answer: A

Explanation:

Mean is calculated using the mid-values of classes.

Question 35

The mean of 10 numbers is 7. If each number is multiplied by 12, find the mean of new set of numbers.

- (a) 82 (b) 48
(c) 78 (d) 84

Answer: D

Explanation:

Total of 10 numbers = $10 \times 7 = 70$

If each number is multiplied by 12

New total = 70×12

∴ New mean = $\frac{70 \times 12}{10} = 84$

Question 36

The mean of 9, 11, 13, p, 18 and 19 is p. Find the value of 'p'.

- (a) 12 (b) 13
(c) 14 (d) 15

Answer: C

Explanation:

The given numbers are 9, 11, 13, p, 18, 19

⇒ Number of observations = 6

$$\Rightarrow \text{Mean} = p$$

$$\therefore p = \frac{9+11+13+p+18+19}{6}$$

$$\therefore p = \frac{70+p}{6}$$

$$\therefore 6p = 70 + p$$

$$\therefore 5p = 70$$

$$\therefore p = 14$$

Question 37

What is the value of 'n' if the mean of first 9 natural numbers is $\frac{5n}{9}$?

(a) 7

(b) 8

(c) 9

(d) 11

Answer: C

Explanation:

$$\text{Mean of first 9 natural numbers} = \frac{1+2+\dots+9}{9}$$

$$\frac{45}{9} = 5$$

$$\text{Given mean of first 9 natural numbers is } \frac{5n}{9}$$

$$\frac{5n}{9} = 5$$

$$n = \frac{9 \times 5}{5} = 9$$

Question 38

In the set above, which is larger: the median, the mean, or the mode?

(a) Mean

(b) Median

(c) All are equal

(d) Mode

Answer: A

Explanation:

Begin by ordering the set from smallest to largest:

6, 7, 8, 8, 9, 10, 11, 12

Already, we see that the mode is 8. Find the median by taking the average of the two middle numbers.

$$8 + 9 = 17$$

Find the mean by adding all numbers and dividing by the total numbers of terms;

$$6 + 7 + 8 + 8 + 9 + 10 + 11 + 12 = 88$$

of the three, the mean of the set is the largest.

Question 39

Column A.

The mean of the sample of numbers 2, 5, and 10.

Column B

The mean of the sample of numbers 1, 5, and 15.

(a) The quantity in column B is greater

(b) The quantity in Column A is greater.

(c) The two quantities are equal.

(d) The relationship cannot be determined from the information given.

Answer: A

Explanation:

The arithmetic mean is the average of the sum of a set of numbers divided by the total number of numbers in the set. This is not to be confused with median or mode.

In Column A, the mean of 5.66 is obtained when the sum (17) is divided by the number of values in the set (3).

In column B, the mean of 7 is obtained when 21 is divided by 3. Because 7 is greater than 5.66, column B is greater. The answer is column B.

Question 40

The median of a given frequency distribution is found graphically with the help of __.

- (a) Histogram (b) Frequency curve
(c) Frequency polygon (d) Ogive

Answer: D

Explanation:

Ogive or cumulative frequency curve is used to find the median.

Question 41

'More than' ogive is __.

- (a) an ascending curve (b) a descending curve
(c) first ascending curve and then descending curve (d) First descending curve and then I ascending curve

Answer: B

Explanation:

'More than' ogive is a descending curve.

Question 42

IN A VILLAGE OF 200 FARMS, A STUDY CONDUCTED FIND THE CROPPING PATTERN. Out of the 50 farms surveyed 50% grew only wheat. Identify the population and the sample here.

- (a) The sample population is 200 farms (b) The sample population is 5 farms
(c) The sample population is 10 farms. (d) The sample population is 50 farms

Answer: D

Explanation:

Population or the universe in statistics means totality of the items under study. So, the population here is 200 farms. Sample refers to a group or selection of the population from which information is to be obtained. Out of 200 farms, only 50 farms are selected for survey. Therefore, the sample population is 50 farms.

PAST EXAMINATION QUESTIONS:

MAY 2018

Question 1

Frequency density is used in the construction of

- (a) Histogram (b) Ogive
(c) Frequency polygon (d) None when the classes are of unequal width

Answer: A**Explanation:**

Frequency density is used in the construction of histogram

Question 2**Divided bar chart is considered for**

- (a) Comparing different components of a variable
 (b) The relation of different components to the table
 (c) None
 (d) (a) and (b)

Answer: D**Explanation:**

Divided bar chart is considered for comparing different components of a variable and the relation of different components to the table

NOV 2018

Question 1**The following frequency distribution**

X	12	17	24	36	45
F	2	5	3	8	9

Is classified as:

- (a) Continuous distribution
 (b) Discrete distribution
 (c) Cumulative frequency distribution
 (d) None of the above

Answer: c**Explanation:**

X	12	17	24	36	15
F	2	5	3	8	9

Is classified as discrete distribution.

Question 2**Histogram is useful to determine graphically the value of**

- (a) Arithmetic mean
 (b) Median
 (c) Mode
 (d) None of the above

Answer: C**Explanation:**

Histogram is useful to determine graphically the value of "mode"

Question 3**Data are said to be ___ if the investigator himself is responsible for the collection of the data.**

- (a) Primary data
 (b) Secondary data
 (c) Mixed of primary and Secondary
 (d) None of the above

data

Answer: A

Data are said to be primary data if the investigator him responsible for the collection of the data.

Question 4

A suitable graph for representing the portioning of total info sub in statistics is statics is:

- (a) A pie chart (b) A pictograph
(c) An ogive (d) Histogram

Answer: A

Explanation:

A suitable graph for representing the portioning of total into parts in statistics is A pie chart.

Question 5

The number of times a particular item occurs in a class its

- (a) Mean (b) Frequency
(c) Cumulative frequency (d) None

Answer: B

Explanation:

The number of times particular items occur in a class interval is called its frequency.

Question 6

An ogive is a graphical representation of

- (a) Cumulative frequency distribution (b) A frequency distribution
(c) Ungrouped data (d) None of the above

Answer: A

Explanation:

An 'O' give is a graphical representation of cumulative frequency distribution.

Question7

class	0-10	10-20	20-30	30-40	40-50
Frequency	4	6	20	8	3

For the class 20-30. Cumulative frequency is:

- (a) 10 (b) 26
(C) 30 (d) 41

Answer: C

Explanation:

C.I	F	C.F
0-10	4	4
10-20	6	10

20-30	20	30
30-40	8	38
40-50	3	

Cumulative frequency of class Interval '20-30' is 30

MAY 2019

Question 1

_____ Series is continuous.

- (a) Open ended
(c) Close ended
- (b) Exclusive
(d) Unequal call intervals

Answer: B

Explanation:

Continuous series means where frequencies are given along with value of the variable in the form of class intervals. For example, here: ...20 is the lower and 30 the upper limit 20-30 class interval.

Question 2

Which of the following graph is suitable for cumulative frequency distribution?

- (a) Ogives
(c) G.M
- (b) Histogram
(d) A.M

Answer: A

Explanation:

An ogive is type of frequency polygon that shows cumulative frequencies. In other words, the cumulative percent are added on the graph from the left to right.

Question 3

Histogram is used for finding

- (a) Mode
(c) Median
- (b) Mean
(d) None

Answer: A

Explanation:

A histogram is used for continuous data, where the bins represent ranges of data, while a bar chart is plot of categorical variables.

Question 4

Ogive graph is used for finding

- (a) Mean
(c) Median
- (b) Mode
(d) None

Answer: C

Explanation:

Determined the median graphically from the data given below. Cumulative frequency

curve is also known as OGIVE. The point on the x – axis, at which the perpendicular drawn from the intersection of two ogives meet. Determines are median.

Question 5

Histogram can be shown as

- (a) Ellipse (b) Rectangle
(c) Hyperbola (d) Circle

Answer: B

Explanation:

A histogram is a diagram consisting of rectangles whose area is proportional to the frequency of a variable and whose width is equal to the class interval... these graphs shown on a histogram.

NOV 2019

Question 1

The graphical representation of cumulative frequency distribution is called.

- (a) Histogram (b) Hystrogram
(c) Ogive (d) None

Answer: C

Explanation:

A curve that represents the cumulative frequency distribution of a grouped data on a graph is called ogive.

Cumulative frequency on y-axis

Class interval on x-axis.

DEC 2020

Question 1

The average of salaries in a factory is Rs.47, 000. The statement that the average salary Rs.47, 000 is ____

- (a) Descriptive statics (b) Inferential
(c) Detailed (d) Undetailed

Answer: A

Explanation:

Descriptive statistics are brief descriptive coefficients that summarize a given data set, which can be either a representation of the entire or a sample of a population.

Descriptive statistics are broken down into measures of central tendency and measures of variability (spread).

Question 2

Statistics cannot deal with ____ data.

- (a) Quantitative (b) Qualitative
(c) Textual (d) Attribute

Answer: C

Explanation:

Textual data refer to systematically collected material consisting of written, printed, or electronically published words, typically either purposefully written or transcribed from speech. Text collected for use as data typically reflects a conscious research purpose, motivated by a ... Entry. Data, Spatial.

Question 3

Sweetness of a sweet dish is _____

- (a) Attribute (b) Discrete Variable
(c) Continuous Variable (d) Variable

Answer: A

Explanation:

An attribute refers to the quality of a characteristic. The theory of attributes deals with qualitative types of characteristics that are calculated by using quantitative measurements. Therefore, the attribute needs slightly different kinds of statistical treatments, which the variables do not get. Attributes refer to the characteristics of the item under study, like the habit of smoking, or drinking. So 'smoking' and 'drinking' both refer to the example of an attribute.

Question 4

Census reports are used as a source of _____ data.

- (a) Secondary (b) Primary
(c) Organize (d) Confidential

Answer: A

Explanation:

Secondary data is the data that has already been collected through primary sources and made readily available for researchers to use for their own research. It is a type of data that has already been collected in the past.

Question 5

Types of cumulative frequencies are _____

- (a) 1 (b) 2
(c) 3 (d) 4

Answer: B

Explanation:

There are two types of Cumulative Frequency Curves (or Ogives) :

- + More than type Cumulative Frequency Curve.
- . Less than type Cumulative Frequency Curve

Question 6

You are an Auditor of a firm and the firm earns a profit Rs.67, 000/- you stated to them that the annual profit is Rs. 67,000. This is ____ type of statistics.

- (a) Descriptive (b) Detailed
(c) Non detailed (d) Inferential

Answer: A

Explanation:

Descriptive - What are the 3 main types of descriptive statistics? The 3 main types of descriptive statistics concern the frequency distribution, central tendency, and variability of a dataset. Distribution refers to the frequencies of different responses. Measures of central tendency give you the average for each response.

Question 7

They ____ are used usually when we want to examine the relationship between two variables.

- (a) Bar Graph (b) Pie Chart
(c) Line Chart (d) Scatter Plot

Answer: D

Explanation:

Scatter Plot a graph in which the values of two variables are plotted along two axes, the pattern of the resulting points revealing any correlation present.

Question 8

Decomposition of time series is known as ____

- (a) Detrending (b) Histogram
(c) Analysis of time series (d) Historiogram

Answer: a

Explanation:

Decomposition of time series is known as Detrending

IAN 2021

Question 1

A bar chart is drawn for

- (a) Continuous data (b) Nominal data
(c) Time series data (d) Comparing different components

Answer: D

Explanation:

A bar diagram makes it easy to compare sets of data between different groups at a glance. The graph represents categories on one axis and a discrete value in the other. The goal is to show the relationship between the two axes. Bar charts can also show big changes in data over time.

Question 2**A tabular presentation can be used for**

- | | |
|----------------------|------------------------------------|
| (a) Continuous data | (b) Nominal data |
| (c) Time Series data | (d) Comparing different components |

Answer: B**Explanation:**

Data Tables or Tabular Presentation. A table facilitates representation of even large amounts of data in an attractive, easy to read and organized manner. The data is organized in rows and columns. This is one of the most widely used forms of presentation of data since data tables are easy to construct and read.

Question 3**A variable with qualitative characteristics is known as**

- | | |
|-------------------------|---------------------------|
| (a) Quality variable | (b) an attribute |
| (c) A discrete variable | (d) A continuous variable |

Answer: B**Explanation:**

A qualitative variable, also called a categorical variable, is a variable that isn't numerical. It describes data that fits into categories. For example: Eye colors (variables include: blue, green, brown, hazel).

Question 4**The accuracy and consistency of data can be verified by**

- | | |
|-----------------------|-----------------------|
| (a) Scrutiny | (b) Internal checking |
| (c) External Checking | (d) Double Checking |

Answer: A**Explanation:**

The accuracy and consistency of data can be verified by. Internal checking. External checking. **Scrutiny**.

Question 5**From a histogram one cannot compute the approximate value of**

- | | |
|------------|------------------------|
| (a) Mode | (b) Standard deviation |
| (c) Median | (d) Mean |

Answer: B**Explanation:**

A standard deviation is a statistic that measures the dispersion of a dataset relative to its mean and is calculated as the square root of the variance. ... If the data points are further from the mean, there is a higher deviation within the data set; thus, the more spread out the data, the higher the standard deviation. Hence From a histogram one cannot compute the approximate value of Standard deviation

Question 6

The left part of a table providing the description of rows is called

- (a) Caption (b) Box – head
(c) Stub (d) Body

Answer: C

Explanation:

Stub is the left part of the table providing the description of the rows. Body: The body is the main part of the table that contains the numerical figures.

Question 7

Mode can be obtained from _____

- (a) Frequency polygon (b) Histogram
(c) Ogive (d) All of the above

Answer: B

Explanation:

The mode of a frequency distribution can be determined graphically from HISTOGRAM . HISTOGRAM: Histogram is the graphical representation of a grouped frequency distribution in exclusive form with continuous classes in the form of rectangles with class intervals as bases and the corresponding frequencies as heights

Question 8

Most of the commonly used distributions provide a

- (a) Bell-shaped (b) U – shaped
(c) J – shaped curve (d) Mixed curve

Answer: A

Explanation:

Normal distribution, also called Gaussian distribution, the most common distribution function for independent, randomly generated variables. Its familiar bell-shaped curve is ubiquitous in statistical reports, from survey analysis and quality control to resource allocation.

Question 9

Which of the following is suitable for the graphical representation of a cumulative frequency distribution?

- (a) Frequency polygon (b) Histogram
(c) Ogive (d) Pie chart

Answer: C

Explanation:

A curve that represents the cumulative frequency distribution of grouped data is called an ogive or cumulative frequency curve.

Question 10**Sweetness of sweet dish is**

- (a) An Attribute (b) A discrete variable
(c) A continuous variable (d) A variable

Answer: A**Explanation:**

An attribute is defined as a quality or characteristic of a person, place, or thing. Real life individuals and fictional characters possess various attributes. For example, someone might be labeled beautiful, charming, funny, or intelligent, Sweetness of sweet dish

JULY 2021**Question 1****There were 200 employees in an office in which 150 were married. Total male employees were 160 out of which 120 were married. What was the number of female unmarried employees?**

- (a) 30 (b) 40
(c) 50 (d) 10

Answer: Options (d)**Explanation**

Total Female Employee = $200 - 160 = 40$

Total Female Married = $150 - 120 = 30$

Total Female Unmarried = $40 - 30 = 10$

Ans: Female Unmarried Employees = 10

Question 2**Data collected on religion from the census reports are**

- (a) Primary data (b) Unclassified data
(c) Sample data (d) Secondary data

Answer: Options (d)**Explanation**

Data collected on religion from census reports are secondary data. Secondary data is the second-hand information as it is not collected by the user. Thus, secondary data refers to the data which is already collected and published by other authorities. For example, government census report is a secondary data.

Question 3**Which of the following diagram the most appropriate is to represents various heads in total cost?**

- (a) Pie chart (b) Bar graph
(c) Multiple line chart (d) Scatter plot

Answer: Options (a)

Explanation

Different diagram patterns represent different kinds of data.

However, here we are concerned about the monthly expenditure of different items bought by a family and a pie diagram would do proper justice to it.

A pie diagram is circular as its name suggests and it is divided into various sections which differ on the data which is being dealt with.

The length of the arc in each section usually refers to the quantity.

It is usually used to show data that can be represented in a percentage format.

Question 4

In a graphical representation of data, the largest numerical value is for is the smallest numerical value is 25. If classes desired are 4 then which interval is

- (a) 45 (b) 5
(c) 20 (d) 7.5

Answer: Options (b)

Explanation:

In a graphical representation of data, the largest numerical value is for is the smallest numerical value is 25. If classes desired are 4 then which interval is 5

Question 5

In a graphical representation of data, ideographs are also called as

- (a) Picto-graphs (b) Asymmetry graphs
(c) Symmetry graphs (d) Pictograms

Answer: Options (d)

Explanation:

A pictogram, also called a pictograms, pictograph, or simply picto, and in computer usage an icon, is a graphic symbol that conveys its meaning through its pictorial resemblance to a physical object.

Question 6

_____ Means separating items according to similar characteristics groping then into various classes

- (a) Classification (b) Editing
(c) Separation (d) Tabulation

Answer: Options (a)

Explanation:

Classification means separating items according to similar characteristics and grouping them into various classes.

Question 7

Frequency density of a class interval is the ratio of_

- (a) Class frequency to the total frequency (b) Class length to class frequency

(c) Class frequency to the cumulative frequency

(d) Frequency of that class interval to the corresponding class length

Answer: Options (d)

Explanation:

Frequency density of a class interval may be defined as the ratio of the frequency of that class interval to the corresponding class length. To have better understanding on frequency density of a class interval, let us consider the frequency distribution given below. That is, 0.60 and 0.80 respectively

Question 8

A graph that uses vertical bars to represent data is called a

(a) Line graph

(b) Scatter plot

(c) Vertical graphs

(d) Bar graphs

Answer: Options (d)

Explanation:

A bar chart or bar graph is a chart or graph that presents categorical data with rectangular bars with heights or lengths proportional to the values that they represent. The bars can be plotted vertically or horizontally. A vertical bar chart is sometimes called a column chart.

Question 9

In normal distribution, Mean, Median and Mode are

(a) Zero

(b) Not equal

(c) Equal

(d) Null

Answer: Options (c)

Explanation:

The mean, median, and mode of a normal distribution are equal. The area under the normal curve is equal to 1.0. Normal distributions are denser in the centre and less dense in the tails.

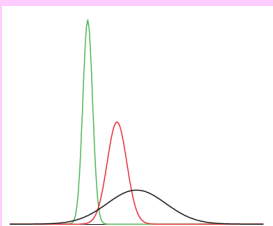

DEC 2021

Question 1

In a study about the male and female students of commerce and science departments of a college in 5 years, the following data's were obtained:

1995

70% female students

65% read commerce

2000

75% female Students

40% read Science

Question 3

A student marks in five subject S1, S2, S3, S4 and S5 are 86, 79, 90, 88 and 89. If we need to draw a Pie chart to represent these marks, then what will be the Central angle for S3?

- (a) 103.2° (b) 75°
(c) 105.6° (d) 94.8°

Answer: b

Explanation:

Total Marks = 86 + 79 + 90 + 88 + 89 = 432

Marks in S3 = 90

Central Angle = $\frac{90}{432} \times 360 = 75^\circ$

Question 4

Ogive curves cannot be used to determine

- (a) Mean (b) Mode
(c) Median (d) Range

Answer: b

Explanation:

This question seems to be wrong. The correct question should be "Ogive curves can be used to determine:"

The answer would then be (b) Median.

Question 5

The following data relate to the marks of a group of students:

Marks	Below 10	Below 20	Below 30	Below 40	Below 50
No. of students	15	38	65	84	100

How many students got marks more than 30?

- (a) 65 (b) 50
(c) 35 (d) 43

Answer:

Explanation:

From the table it is clear that total number of students = 100, and the number of students who got marks below 30 = 65.

Therefore, number of students who got marks more than 30 = 100 - 65 = 35.

Question 6

The following data relate to the marks 48 students in statistics:

56	10	54	38	21	43	12	22
48	51	39	26	12	17	36	19

48	36	15	33	30	62	57	17
5	17	45	46	43	55	57	38
43	28	32	35	54	27	17	16
11	43	45	2	16	46	28	45

What are the frequency densities for the class intervals 30-39, 40-49, 50-59?

- (a) 0.20, 0.50, 0.90
 (b) 0.1875, 0.1667, 0.2083
 (c) 0.70, 0.90, 1.10
 (d) 0.90, 1.00, 0.80

Answer: d

Explanation:

$$\text{Frequency Density} = \frac{\text{Class Frequency}}{\text{Class Length}}$$

Class Interval	Observations	Frequency
30 - 39	38, 39, 36, 33, 30, 38, 32, 35	9
40 - 49	43, 48, 48, 45, 46, 43, 43, 43, 45, 46, 45	11
50 - 59	56, 54, 51, 57, 55, 57 54	7

Therefore, Frequency Density for the Class interval 30- 39 = $9 / 10 = 0.90$

Frequency Density for the class interval 40 49 = $11 / 10 = 1.10$

Frequency density for the class interval 50 59 = $7 / 10 = 0.70$.

Question 7

Multiple axis line chart is considered when

- (a) There is more than one time series
 (b) The Units of the variables are different.
 (c) In any case.
 (d) If there are more than one time series and unit of variables are different.

Answer: d

Explanation:

If there are more than one time series and unit of variables are different then multiple Axis line chart is considered.

JUNE 2022

Question 1

Less than 'o' give curve give -

- (a) Mean
 (b) Median
 (c) Mode
 (d) MD

Answer: b

Explanation:

Less than 'o' give curve gives Median.

Question 2

If a data collected from a census Report. What type of data it is :-

- (a) Time series data (b) Primary data
(c) Secondary data (d) Geographical data

Answer:

Explanation:

If a data collected from a census report is known as secondary data.

Question 3

Sweetness is an

- (a) Attribute (b) Quality
(c) Quantity (d) None of these

Answer: d

Explanation:

Sweetness is an Attribute (quality)

Question 4

Which of the following is not a way of Presenting data?

- (a) Tabular form (b) Textual form
(c) Graphical form (d) None of these

Answer: d

Explanation:

Regression Analysis is not a way of Presenting data.

Question 5

Histogram can be drawn from

- (a) Class interval are equal (b) Class interval are unequal
(c) Frequency of class interval are equal (d) None

Answer: a

Explanation:

Histogram can be drawn from class Interval are equal.

Question 6

Which of following does not form characteristics in dividing the data?

- (a) No. of auditors auditing Accounts (b) No. of files audited by auditor
(c) No of files audited less than 6, less than , less than 10 (d) Files less than, moderate than, higher than

Answer: d

Explanation:

Files less than, moderate than, higher than does not form characteristics in dividing the data.

Question 7

If the cumulative frequency are plotted on axis then which type of curve is formed

- (a) Ogive (b) Frequency curve
(c) Histogram (d) Frequency Polygon

Answer: a

Explanation:

'O' Give [∴ C.F is used for constructed 'O' Give]

Question 8

Which one is research data?

- (a) Discrete and Continuous (b) Qualitative and Quantitative
(c) Processed and Unprocessed (d) Organise and unorganised data

Answer: c

Explanation:

Processed and unprocessed data is a research data.

Question 9

The profitability of a blue chip company is shown by -

- (a) bell shape curve (b) U shape curve
(c) J shape curve (d) Mixed curve

Answer:

Explanation:

The profitability of a blue chip company is shown by bell shape Curve.

DEC 2022

Question 1

Which one of the following is a source of primary data?

- a) Government records b) Research Articles
c) Journals d) Questionnaire filled by enumerators

Answer: Options (a)

Explanation:

Public records produced from federal, state, local and international governments or intergovernmental organizations (NGOs) provide primary source material beneficial to nearly all research interests.

Question 2

_____ is based on all the observations and _____ is based on the central fifty percent of the observations

- a) Mean deviation, Range
 b) Mean deviation, quartile deviation
 c) Range, standard deviation
 d) Quartile deviation, standard deviation

Answer: Options (d)

Explanation:

The Quartile Deviation could be a basic way to appraise the spread of a conveyance approximately a degree of its central inclination (more often than not the cruel). So, it gives you an thought almost the extend inside which the central 50% of your test information lies.

Hence, Quartile deviation, standard deviation is Answer.

Question 3

Which is the left part of the table providing the description of the rows?

- a) Caption
 b) Box head
 c) Stub
 d) Body

Answer: Options (d)

Explanation:

stub is a part of table which describes the rows situated in the left of a table

Question 4

The suitable formula for computing the number of the class intervals is:

- a) $3.322 \log N$
 b) $0.322 \log N$
 c) $1+3.322 \log N$
 d) $1-3.322 \log N$

Answer: Options (c)

Explanation:

The number of classes given in the question is n and total frequency is N
 We know that Sturges rule is used to find the number of classes which is used in a histogram or frequency distribution.

From Sturges rule we can write.

$$K=1+3.322\log N$$

Put the values of number of classes and total frequency in the above equation.

Therefore, we will get

$$n=1+3.322\log N$$

We can write the above equation as $n=1+3.3\log N$.

Hence, the correct option is (C).

Question 5

Give for more than type and less than type of distribution intersect at

- a) Mean
 b) Median
 c) Mode
 d) Origin

Answer: Options (b)

Explanation:

In Ogive for more than type and less than type of distribution intersect at Median.

CHAPTER - 14 MEASURES OF CENTRAL TENDENCY AND DISPERSION

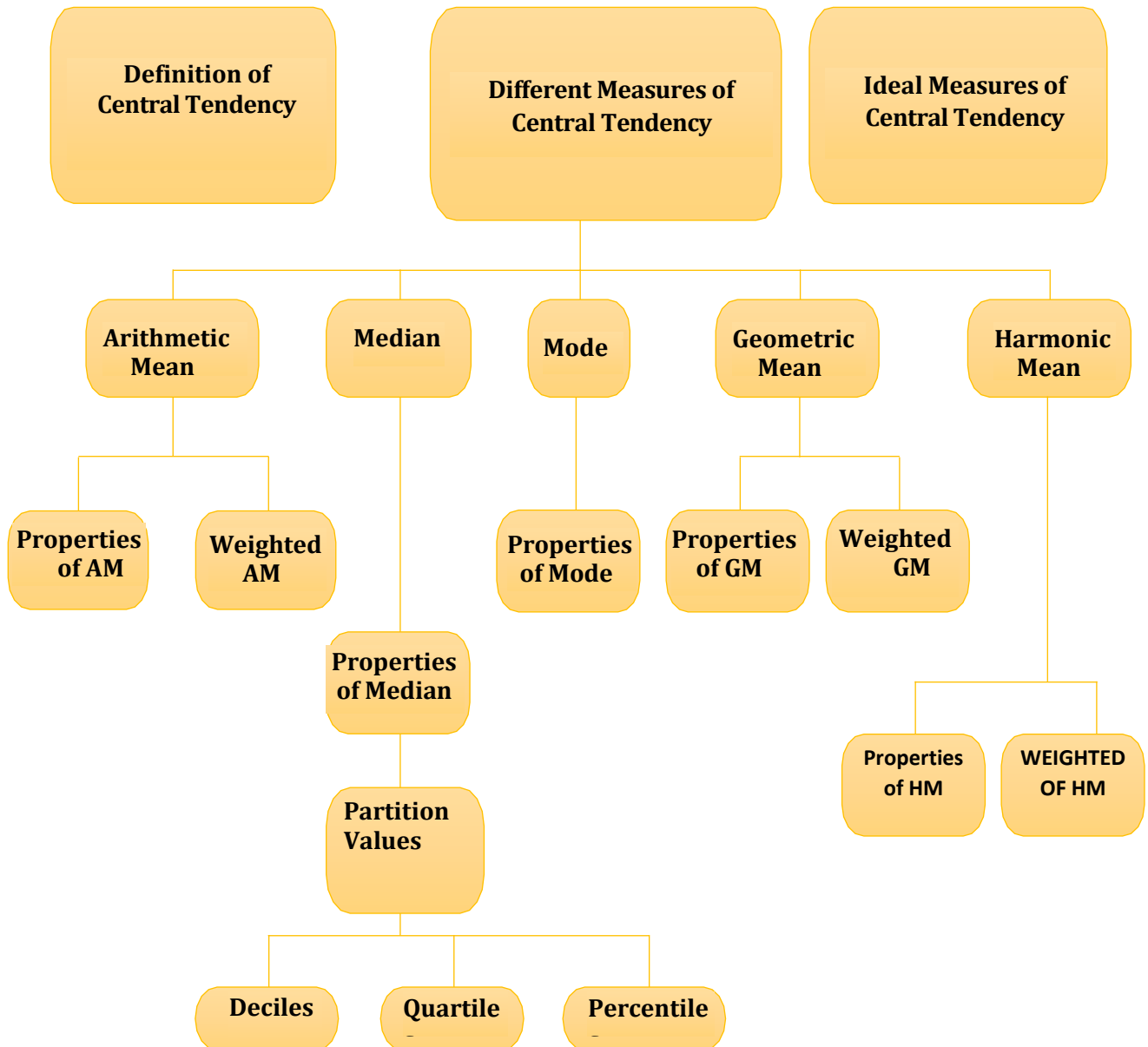

UNIT I: MEASURES OF CENTRAL TENDENCY

CENTRAL TENDENCY

Tendency of a given set of observations to cluster around a single central or middle value and the single value that represents the given set of observations is described as a measure of central tendency or, location, or average.

ARITHMETIC MEAN

The AM may be defined as the sum of all the observations divided by the number of observations. Thus, if a variable x assumes n values $x_1, x_2, x_3, \dots, x_n$, then the AM of x , to be denoted by \bar{x} , is given by:

		Formulas	No. of Boxes
Individual Series			
Direct Method	$\therefore = \sum x / N$		x
Shortcut Method	$\therefore = A + \sum dx / N$		x dx
Discrete Series			
Direct Method	$\therefore = \frac{\sum fx}{\sum f}$		x f fx
Shortcut Method	$\therefore = A + \frac{\sum fdx}{\sum f}$		x f dx fdx
Continuous Series			
Direct Method	$\frac{\sum fx}{\sum f}$		x f x(M.V) fx
Shortcut Method	$= A + \frac{\sum fdx}{\sum f}$		x f x (M.V) dx fdx
Step Deviation	$= A + \frac{\sum fdx}{\sum f} \times c$		x f x (M.V) dx dx' fdx'

MEDIAN – PARTITION VALUES

$$\text{Median} = l + \frac{h}{f} \left(\frac{N}{2} - c \right)$$

Where:

l = lower class boundary of the median class

h = Size of the median class interval

f = Frequency corresponding to the median class

N = Total number of observations i.e. sum of the frequencies

c = Cumulative frequency preceding median class.

Types of median

Calculation of Quartiles, Deciles and Percentiles

- **For Continuous Series**
 1. Q_1 = Size of $N/4$ th item
 2. Q_3 = Size of $3N/4$ th item
 3. D_1 = Size of $N/10$ th item
 4. D_9 = Size of $9N/10$ item
 5. P_1 = Size of $N/100$ th item
 6. P_{99} = Size of $99N/100$ th item
- **Formula to be used in continuous series:**
 1. $Q_1 = L_1 + N/4 - c.f^*i/f$
 2. $Q_3 = L_1 + 3N/4 - c.f^*i/f$
 3. $D_1 = L_1 + N/10 - c.f^*i/f$
 4. $D_9 = L_1 + 9N/10 - c.f^*i/f$
 5. $P_1 = L_1 + N/100 - c.f^*i/f$
 6. $P_{99} = L_1 + 99N/100 - c.f^*i/f$

Mode

Formula of Mode :

$$Z = l_1 + \frac{f_1 - f_0}{2f_1 - f_0 - f_2} \times i$$

where,

Z = value of Mode

l_1 = lower limit of modal class

f_0 = Frequency of the preceding modal class

f_2 = Frequency of the subsequent modal class or post modal class

i = Class interval of the modal class

GEOMETRIC MEAN & HARMONIC MEAN & WEIGHTED MEAN

Geometric Mean: $GM = \sqrt[n]{\prod_{i=1}^n x_i} = \sqrt[n]{x_1 x_2 x_3 \dots x_n}$

Harmonic Mean: $HM = \frac{n}{\sum_{i=1}^n \frac{1}{x_i}} = \frac{n}{\frac{1}{x_1} + \frac{1}{x_2} + \frac{1}{x_3} + \dots + \frac{1}{x_n}}$

Weighted Mean: $WM = \frac{\sum_{i=1}^n w_i x_i}{\sum_{i=1}^n w_i} = \frac{w_1 x_1 + w_2 x_2 + w_3 x_3 + \dots + w_n x_n}{w_1 + w_2 + w_3 + \dots + w_n}$

Relationship between Mean, Median and

Mean - Mode = 3(Mean- Median)
Mode = 3 Median - 2 Mean

Relation between AM, GM, and HM

AM > GM > HM

**Question 1****Relationship between Mean, Median and Mode**

- (a) Mean – Mode = 3(Mean – Median) (b) Mode = 3 Median – 2 Mean
 (c) Both (a & b) (d) None of these

Answer: C**Explanation:**

If a frequency distribution is positively skewed, the mean is greater than median and median is greater than mode.

Question 2**If median – 20 and mean-22.5 in a moderately skewed distribution then compute approximate value of mode**

- (a) 15 (b) 20
 (c) 25 (d) 30

Answer: A**Explanation:**

Mean – Mode = 3(Mean – Median)
 22.5 – Mode = 3(22.5 – 20)
 22.5 – Mode = 7.5
 Mode = 22.5 – 7.5
 Mode = 15

Question 3**A numerical value used as a summary measure for a sample, such as sample mean, is known as a**

- (a) Population parameter (b) Sample parameter
 (c) Sample statistic (d) population mean

Answer: C**Explanations:**

If it pertains to sample it is called a statistic, if it pertains to population, it is called a parameter.

Question 4**Since the population size is always larger than the sample size, then the sample statistic**

- (a) Can never be equal to the population parameter (b) Can never be zero
 (c) Can never be smaller than the population parameter (d) None of the above answers is correct

Answer: D**Explanation:**

Sample statistic will depend upon the sample chosen. It can be less than, greater than, equal to population parameter. It can assume the value of zero.

Question 5**Mu is an example of a**

- (a) Population parameter (b) Sample statistic
(c) Population variance. (d) Mode

Answer: A**Explanation:**

M is a standard representation for population parameter.

Question 6**The mean of a sample is**

- (a) Always equal to the mean of the population (b) Always smaller than the mean of the population
(c) Computed by summing the data values and dividing the sum by (n - 1) (d) Computed by summing all the data values and dividing the sum by the number of items

Answer: D**Explanation:**

Mean = Total of sample values/ sample size

Question 7**The sum of the percent frequencies for all classes will always equal**

- (a) One (b) The number of classes
(c) The number of items in the study (d) 100

Answer: D**Explanation:**If we count the total frequency, it is equal to the sample size $n. \frac{n}{n} \times 100 = 100$ **Question 8****In a five number summary, which of the following is not used for data summarization?**

- (a) The smallest value (b) The largest value
(c) The median (d) The 25th percentile

Answer: D**Explanation:**The 25th percentile**Question 9****Since the mode is the most frequently occurring data value, it**

- (a) Can never be larger than the mean (b) Is always larger than the median
(c) Is always larger than the mean (d) None of the above answers is correct.

Answer: D**Explanation:**

The mean, median and mode values will be distributed according to the skewness of the distribution. Accordingly, mode can be greater than or less than mean or mode.

Question 10**The following table gives the distribution of 100 accidents during seven days of the week of a given month. During a particular month there were 5 Fridays and Saturdays and four each of other days. Calculate the average number of accidents per day.**

Days	Sun	Mon	Tue	Wed	Thru	Fri	Sat.	Total
Number of accidents	20	22	10	9	11	8	20	100

(a) 14

(b) 12

(c) 17

(d) 19

Answer: A**Explanation:****Calculation of number of Accidents per day**

Day	No. of Accidents (x)	No. of days in Month (f)	Total fx
Sunday	20	4	80
Monday	22	4	88
Tuesday	10	4	40
Wednesday	9	4	36
Thursday	11	4	44
Friday	8	5	40
Saturday	20	5	100
Total	100	N = 30	$\Sigma fx = 428$

$$\frac{\Sigma fx}{N} = \frac{428}{30} = 14.27$$

14 accidents per day

Question 11

Following are the daily wages in Rupees of a sample of 9 workers: 58, 62, 48, 53, 70, 52, 60, 84, 75. Compute the mean wage.

(a) 62.44

(b) 62.04

(c) 60.44

(d) 31.22

Answer: a**Explanation:**

Let x denote the daily wage in rupees.

Then as given $x_1 = 58, x_2 = 62, x_3 = 48, x_4 = 53, x_5 = 70, x_6 = 52,$ $x_7 = 60, x_8 = 84$ and $x_9 = 75$. Applying (15.1.1) the mean wage is

Given by,

$$= \frac{\Sigma x_i}{n}$$

$$\frac{58+62+48+53+70+52+60+84+75}{9}$$

$$\frac{562}{9} = 62.44$$

Question 12

Find the AM for the following distribution:

class interval	350-369	370-389	390-409	410-429	430-449	450-469	470-489
Frequency	23	38	58	82	65	31	11

(a) 416

(b) 416.17

For more Info Visit - www.KITest.in

(c) 416.71

(d) 41.71

Answer: C**Explanation:****Computation of AM**

Class Interval	Frequency(f)	Mid-Value(x)	d= xi-A xi = -419.50	fx
(1)	(2)	(3)	(4)	(5) = (2) × (4)
350 – 369	23	359.50	-3	-69
370 – 389	38	379.50	-2	-76
390 – 409	58	399.50	-1	-58
410 – 429	82	419.50	0	0
430 – 449	65	439.50	1	65
450 - 469	31	459.50	2	62
470 - 489	11	479.50	3	33
Total	308	-	-	-43

The required AM is given by

$$\begin{aligned}
 X &= A + \frac{\sum fidi}{N} \times C \\
 &= 419.50 + \frac{(-43)}{308} \times 20 \\
 &= 419.50 - 2.79 \\
 &= 416.71
 \end{aligned}$$

Question 13

The mean salary for a group of 40 female workers is Rs. 5200 per month and that for a group of 60 male workers is Rs. 6800 per month. What is the combined mean salary?

(a) 6160

(b) 616

(c) 6.16

(d) 61.6

Answer: A**Explanation:**As given $n_1 = 40$, $n_2 = 60$, $x_1 = \text{Rs. } 5200$ and $x_2 = \text{Rs. } 6800$

Hence, the combined mean salary per month is

$$\begin{aligned}
 X &= \frac{n_1x_1 + n_2x_2}{n_1 + n_2} \\
 &= \frac{40 \times \text{Rs. } 5200 + 60 \times \text{Rs. } 6800}{40 + 60} \\
 &= 6160
 \end{aligned}$$

Question 14

The sum of the deviation of a given set of individual observations from the arithmetic mean is always infinite. The statement is True or not?

(a) Correct

(b) Incorrect

(c) Error

(d) None

Answer: B**Explanation:**

According to Mathematical properties of the Arithmetic Mean: The sum of the deviation of a given set of individual observations from the arithmetic mean is always zero. Symbolically = 0. It is due to this property that property the arithmetic mean is characterized as the center as the center gravity i.e., the sum of positive deviations from the mean is equal to the sum of negative deviations.

Question 15

The mean age of a combined group of men and women is 30 years. If the mean age of the group of men is 32 and that of women group is 27. Find out the percentage of men and women in the group.

- (a) 30%, 70%
(c) 60%, 40%

- (b) 20%, 80%
(d) 40%, 60%

Answer: C

Explanation:

Let us take group of men as first group and women as second group. Therefore = 32 years, = 27 years, and = 30 years. In the problem, we are not given the number of men and women. We can assume

$$N_1 + N_2 = 100 \text{ and therefore. } N_1 = 100 - N_2$$

Apply =

$$30 = (\text{Substitute } N_1 = 100 - N_2)$$

$$30 \times 100 = 32(100 - N_2) + 27N_2 \text{ or } 5N_2 = 200$$

$$N_2 = \frac{200}{5} = 40\%$$

$$N_1 = (100 - N_2) = (100 - 40) = 60\%$$

Therefore, the percentage of men in the group is 60 and that of women is 40.

Question 16

Median and mode of the wage distribution are known to be Rs. 33.5 and 34 respectively. Find the third missing values.

Wages (Rs.)	No. of Workers
0-10	4
10—20	16
20-30	?
30-40	?
40-50	?
50-60	6
60-70	4
Total	230

- (a) 6
(c) 9

- (b) 10
(d) 40

Answer: D

Explanation:

We assume the missing frequencies as 20 – 30 as x, 30 – 40 as y, and 40 – 50 as $230 - (4 + 16 + x + y + 6 + 4) = 200 - x - y$.

We now proceed further to compute missing frequencies:

Wages (Rs.)	No. of workers	Cumulative frequencies
x	f	cf
0-10	4	4
10-20	16	20
20-30	x	20 + x
30-40	y	20 + x + y
40-50	200-x-y	220
50-60	6	226
60-70	4	230

For more Info Visit - www.KITest.in

	N = 230	
--	---------	--

Apply median =

$$33.5 =$$

$$Y(33.5 - 30) = (115 - 20 - x) 10$$

$$3.5y = 1150 - 200 - 10x$$

$$10x + 3.5y = 950 \dots (i)$$

Apply mode =

$$34 =$$

$$4(3y - 200) = 10(y - x)$$

$$10x + 2y = 800 \dots (ii)$$

Subtract equation (ii) from equation (i),

$$1.5y = 150, y = 100$$

Substitute the value of $y = 100$ in equations (i), we get

$$10x + 3.5(100) = 950$$

$$10x = 950 - 350$$

$$X = \frac{600}{10} = 60$$

$$\text{Third missing frequency} = 200 - x - y = 200 - 60 - 100 = 40.$$

Question 17**Calculate mode from the following data:**

Marks	Frequency
Below 10	4
"20	6
"30	24
"40	46
"50	67
"60	86
"70	96
"80	99
"90	100

(a) 41.3

(b) 40

(c) 40.13

(d) 89

Answer: A**Explanation:**

Since we are given the cumulative frequency distribution of marks, first we shall convert it into the normal frequency distribution:

Marks	Frequencies
0-10	4
10-20	6-4=2
20-30	24-6=18
30-40	46-24=22
40-50	67-46=21
50-60	86-67=19
60-70	96-86=10
70-80	99-96=3
80-90	100-99=1

It is evident from the table that the distribution is irregular and maximum chances are that the distribution would be having more than one mode. You can verify by applying the grouping and analyzing table.

The formula to calculate the value of mode in cases of bio-modal distribution is:

$$\text{Mode} = 3 \text{ median} - 2 \text{ mean.}$$

Computation of Mean and Median

Marks	Mid-Value x	Frequency f	Cumulative frequencies cf	(dx)	fdx
0-10	5	4	4	-4	-16
10-20	15	2	6	-3	-6
20-30	25	18	24	-2	-36
30-40	35	22	46	-1	-22
40-50	45	21	67	0	0
50-60	55	19	86	1	19
60-70	65	10	96	2	20
70-80	75	3	99	3	9
80-90	85	1	100	4	4
	405	$\Sigma f = 100$	528	0	$\Sigma fdx = -28$

Mean = ?

Median = size of item = 50th item

Because 50 is similar to 67 in C.f. column, Median class is 40 – 50

Apply Mode = 3 median – 2 Mean

$$\text{Mode} = 3 \times 41.9 - 2 \times 42.2 = 125.7 - 84.4 = 41.3$$

Question 18

Find the arithmetic mean of the first 7 natural numbers.

- (a) 5 (b) 6
(c) 7 (d) 4

Answer: D

Explanation:

The first 7 natural numbers are 1, 2, 3, 4, 5, 6 and 7.

Let x denote their arithmetic mean.

Then mean = Sum of first 7 natural numbers/number of natural numbers

$$X = (1 + 2 + 3 + 4 + 5 + 6 + 7)/7$$

$$= 28/7$$

$$= 4$$

Hence, their mean is 4.

Question 19

The heights of five runners are 160cm, 137 cm, 149 cm, 153 cm, and 161 cm respectively. Find the mean height per runner.

- (a) 152 (b) 150
(c) 148 (d) 120

Answer: A

Explanation:

Mean height = Sum of the heights of the runners/number of runners

$$= \frac{(160+137+149+153+161)}{5cm}$$

$$= \frac{760}{5cm}$$

$$= 152 \text{ cm.}$$

Hence the mean height is 152 cm.

Question 20

Find the mean of the first five prime numbers.

- (a) 4.6 (b) 6.5
(b) 78 (d) 5.6

Answer: D

Explanation:

The first five prime numbers are 2, 3, 5, 7 and 11.

Mean = Sum of first five prime numbers/number of prime numbers

$$= \frac{(2+3+5+7+11)}{5}$$

$$= \frac{28}{5}$$

$$= 5.6$$

Hence, their mean is 5.6

Question 21

Find the mean of the first six multiples of 4.

- (a) 12 (b) 13
(c) 14 (d) 15

Answer: C

Explanation:

The six multiples of 4 are 4, 8, 12, 16, 20, and 24.

Mean = Sum of the first six multiples of $\frac{4}{\text{No. of multiple}}$

$$= \frac{(4+8+12+16+20+24)}{6}$$

$$= \frac{84}{6}$$

$$= 14.$$

Hence, their mean is 14.

Question 22

If the mean of 9, 8, 10, x, 12 is 15, find the value of x.

- (a) 30 (b) 41
(c) 36 (d) 63

Answer: C

Explanation:

$$\text{Mean of the given numbers} = \frac{(9+8+10+x+12)}{5} = \frac{(39+x)}{5}$$

According to the problem, mean = 15 (given).

$$\text{Therefore, } \frac{(39+x)}{5} = 15$$

$$\rightarrow 39 + x = 15 \times 5$$

$$\rightarrow 39 + x = 75$$

$$\rightarrow 39 - 39 + x = 75 - 39$$

$$\rightarrow x = 36$$

Hence x = 36.

Question 23

If the mean of five observations x , $x+4$, $x+6$, $x+8$, and $x+12$ is 16, find the value of x .

- (a) 154 (b) 54
(c) 451 (d) 541

Answer: C

Explanation:

Mean of the given observations

$$\begin{aligned} &= \frac{x+(x+4)+(x+6)+(x+8)+(x+12)}{5} \\ &= \frac{(5x+30)}{5} \end{aligned}$$

According to the problem mean = 16 (given).

$$\text{Therefore, } \frac{(5x+30)}{5} = 16$$

$$\rightarrow 5x + 30 = 16 \times 5$$

$$\rightarrow 5x + 30 = 80$$

$$\rightarrow 5x + 30 - 30 = 80 - 30$$

$$\rightarrow 5x = 50$$

$$\rightarrow x = \frac{50}{5}$$

$$\rightarrow x = 10$$

Hence, $x = 10$.

Question 24

The mean of 40 numbers was found to be 38. Later on, it was detected that a number 56 was misread as 36. Find the correct mean of given numbers.

- (a) 38 (b) 26
(c) 38.5 (d) 89

Answer: C

Explanation:

Calculated mean of 40 numbers = 38.

Therefore, calculated sum of these numbers = $(38 \times 40) = 1520$.

Correct sum of these numbers

$$= [1520 - (\text{wrong item}) + (\text{correct item})]$$

$$= (1520 - 36 + 56)$$

$$= 1540.$$

Therefore, the correct mean = $\frac{1540}{40} = 38.5$.

Question 25

The mean of the heights of 6 boys is 152 cm. If the individual heights of five of them are 151 cm, 153 cm, 155 cm, 149 cm and 154 cm, find the height of the sixth boy.

- (a) 157 (b) 159
(c) 150 (d) 89

Answer: C

Explanation:

Mean height of 6 boys = 152 cm.

Sum of the heights of 6 boys = $(152 \times 6) = 912$ cm

Sum of the heights of 5 boys = $(151 + 153 + 155 + 149 + 154)$ cm = 762 cm.

Height of the sixth boy

$$= \text{sum of the heights of 6 boys} - (\text{sum of the heights of 5 boys})$$

= (912-762) cm = 150 cm.

Hence, the height of the sixth girl is 150 cm.

Question 26

Find the mode of the following set of marks.

Marks	1	2	3	4	5
Frequency	6	7	7	5	3

(a) 2 and 4

(b) 4 and 3

(c) 2 and 3

(d) 2 and 5

Answer: C

Explanation:

The marks 2 and 3 have the highest frequency. So, the modes are 2 and 3.

Note: The above example shows that a set of observation may have more than one mode.

Question 27

There are 8 number cards with values 0 – 7. Each time a card is drawn at random and the card value is recorded. The frequency refers to the number of times a value is shown.

Card values	0	1	2	3	4	5	6	7
Frequency	8	12	7	10	12	13	12	10

(a) 75,5

(b) 5, 79

(c) 80, 89

(d) None

Answer: A

Explanation:

(a) Mode: 75 kg (highest frequency of 12)

(b) Mode: 5 (highest frequency of 13)

Question 28

The following frequency table shows the marks obtained by students in a quiz. Given that 4 is the mode, what is the least value for x?

Marks	1	2	3	4	5	6
Number of students (frequency)	7	9	10	x	9	11

(a) 12

(b) 10

(c) 3

(d) 6

Answer: A

Explanation:

X is at least 12 (if x is less than 12 then 4 will not be the mode)

Question 29

The mean of the following frequency distribution is

Class Interval	Frequency
0-10	4
10-20	6
20-30	10
30-40	16

40-50**14**

(a) 25

(b) 35

(c) 30

(d) 31

Answer: D**Explanation:**

Class interval	Mid-point	Freq.	Diff, from (A = 25)	fd
0-10	5	4	-20	-80
10-20	15	6	-10	-60
20-30	25	10	0	0
30-40	35	16	10	160
40-50	45	14	20	280
Total	$\Sigma f = 50$			$\Sigma fd = 300$

$$(x) = A + \frac{\Sigma FD}{\Sigma F} = 25 + \frac{300}{50} = 31$$

Question 30

Mean of twenty observations is 15. If two observations 3 and 14 replaced by 8 and 9 respectively, then the new mean will be

(a) 14

(b) 15

(c) 16

(d) 17

Answer: D**Explanation:**

Mean of 20 observations = 15

\therefore Sum of 20 observations = $15 \times 20 = 300$

Replacing 3 and 14 by 8 and 9 will mean that $3 + 14 = 17$ is replaced by $8 + 9 = 17$

Hence there will be no effect on the sum. It will remain 300, so the mean will not change and will remain 15.

Question 31

Factory A	Factory B
No. of wage of earners 250	200
Average daily wage Rs. 2.00	Rs. 2.50

The average of daily wages for the earners of the two factories combined is

(a) Rs. 2.12

(b) Rs. 2.06

(c) Rs. 2.20

(d) Rs. 2.22

Answer: D**Explanation:**

$$\text{Required average} = \frac{250 \times 2.00 + 200 \times 2.50}{250 + 200}$$

$$= \frac{1000}{450}$$

$$= \frac{20}{9}$$

$$= \frac{20}{9}$$

Rs. 2.22

Question 32

The height of 30 boys of a class are given in the following table:

Height in cm	Frequency
--------------	-----------

120-129	2
130-139	8
140-149	10
150-159	7
160-169	3

If by joining of a boy of height 140 cm, the median of the heights is changed from M_1 to M_2 then $M_1 - M_2$ in cm is

- (a) 0.1 (b) -0.1
(c) 0 (d) 0.2

Answer: C

Explanation:

Height in cms	Frequency	Cumulative frequency	Actual Class limit
120-129	2	2	119.5-129.5
130-139	8	10	129.5-139.5
140-149	10	20	139.5-149.5
150-159	7	27	149.5-159.5
160-169	3	30	159.5-169.5
n = 30			

Here $n = 30$

$$\therefore \frac{n}{2} + 1 = 15 + 1 = 16$$

$\therefore 16$ is under cumulative frequency 20. So median class be 140-149

$$L_1 = 139.5, L_2 = 149.5, f = 10, n = 30, c = 10.$$

$$\text{Median } M_1 = L_1 + \frac{L_2 - L_1}{f} \left(\frac{n}{2} - c \right)$$

$$= 139.5 + \frac{10}{10} (15 - 10)$$

$$= 139.5 + \frac{10}{10} \times 5 = 144.5$$

If by joining of a boy of height 140 cms, the $n=31, f=11$

$$\therefore \text{Median } M_2 = 139.5 + \frac{149.5 - 139.5}{11} (15.5 - 10)$$

$$= 139.5 + \frac{10}{11} \times 5.5 = 144.5 \text{ cms}$$

$$\text{Then } M_1 - M_2 = 144.5 - 144.5 = 0$$

Question 33

The marks awarded to seven students in a school admission test were:

	Mathematics	English
A	55	35
B	45	32
C	75	44
D	15	50
E	10	45
F	40	60
G	06	40

Which subject has the better median value?

- (a) Mathematics (b) English
 (c) Both (a) and (b) above (d) None of the above

Answer: B**Explanation:**

The awarded marks in Mathematics and English were arranged in ascending order separately.

Maths	English
06	32
10	35
15	40
40	44
45	45
55	50
75	60

Hence, English has the better median value.

Question 34

Identify the mode of the given distribution.

Marks	4	5	6	7	8
Number of students	3	5	10	6	1

- (a) 7 (b) 1
 (c) 8 (d) 6

Answer: D**Explanation:**

Mode is 6 as it has the highest frequency

Question 35

The given data are the times (in minutes), it takes seven students to go to school from their homes.

11	6	22	7	10	6	15
----	---	----	---	----	---	----

Which statement about the data is false?

- (a) Their median is 11. (b) Their mean is 15.
 (c) Their range is 16. (d) Their mode is 6.

Answer: a**Explanation:**

Arranging the given data in ascending order, we get 6, 6, 7, 10, 11, 15, 22

$$\text{Mean} = \frac{6+6+7+10+11+15+22}{7}$$

$$\frac{77}{7} = 11$$

$$\text{Mode} = 6 \quad \text{Median} = 4^{\text{th}} \text{ value} = 10$$

Question 36

The medians of the following two sets of numbers are equal, and the sets are arranged in ascending order {1, 4, x, 8} and {2, 5, y, 9}. What is y - x?

- (a) -1 (b) 0
(c) -2 (d) 3

Answer: a

Explanation:

Recall that the median of an even-numbered of numbers is the arithmetic mean of the pair of middle terms. Thus $\frac{(4+x)}{2}$ = median of the first set and $\frac{(5+y)}{2}$ = median of the second set. Since both median are equal, we can set the equations equal to each other. $\frac{(4+x)}{2} = \frac{(5+y)}{2}$. Multiply both sides by 2 and we get $4 + x = 5 + y$. we also know that $4 < x < 8$ and $5 < y < 9$, since the sets are arranged in ascending order. This narrows our options for x and y down significantly. Plugging in various values will eventually get you to $x = 7$ and $y = 6$, since $7 + 4 = 11$ and $5 + 6 = 11$, and thus the median in both cases would be 5.5. thus, $y-x = -1$

Question 37

What is the median in the following set of numbers 16, 19, 16, 7, 2, 20, 9, 5.

- (a) 2 (b) 16
(c) 4.5 (d) 12.5

Answer: d

Explanation:

16, 19, 16, 7, 2, 20, 9, 5

Order the numbers from smallest to largest.

2, 5, 7, 9, 16, 19, 20

The median is the number in the middle.

In this case, there is a 9 and 16 in the middle.

When that happens, take the average of the two numbers.

Question 38

Find the median: 4,4,4,4,6,7,9,9,12,12,12,12,12,12,12,18,76,90.

- (a) 11.9 (b) 9
(c) 76 (d) 12

Answer: d

Explanation:

To find the median, arrange the numbers from smallest to largest:

4,4,4,4,6,7,9,9,12,12,12,12,12,12,12,18,76,90

There are 17 numbers in total. Since 17 is an odd number, the median will be the middle number of the set. In this case, it is the 9th number, which is 12.

Question 39

There are 3,500 people in group A and 5,000 people in group B:

Car type	% in group A who own	% in group B who own
Motorbike	4	9
Sedan	35	25
Minivan	22	15
Van	9	12
Coupe	3	6

What is the median of the number of people in group B who own either a minivan.Van or coupe?

- (a) 600 (b) 300
(c) 1500 (d) 750

Answer: A

Explanation:

Treat the percentage as a list, as we are including every demographic from the 3 vehicle types mentioned. If we do each $0.06(5000)$, $0.12(5000)$, and $0.15(5000)$ we note from observation that the median, or middle value, would have to be the 12% row
Since the sample size does not change. The question asks for EITHER of 3 categories, so we can ignore the other two.

$0.12(5000) = 600(\text{van})$ is the median of the 3 categories.

8, 12, 9, 8, 7, 11, 10, 6

Question 40

The grades on a test taken by 15 students are 50, 70, 87, 95, 100, 34, 56, 76, 43, 88, 92, 76, 82, 45, and 65 respectively. What was the medians score for this test?

- (a) 73 (b) 76
(c) 70 (d) 89

Answer: b

Explanation:

To solve this problem, we must be aware of the definition of a median for a set of numbers. The median is defined as the number that is in middle of a set of numbers sorted from smallest to largest. Therefore, we must first sort the numbers from largest to smallest.

34,43,45,50,56,65,70,76,76,87,88,92,95,100

43,45,50,56,65,70,76,81,87,88,92,95

45,50,56,65,70,76,76,87,88,92

50, 56, 65, 70, 76,76,87,88

56, 65, 70,76,76,87

65, 70, 76, 76

70, 76, 76

76

Then by slowly eliminations the smallest and the largest numbers we find that the median score for this test is 76.

Question 41

Set A = [-10, 4, 2, -14, -2]

Quantity A: The mean of Set A

Quantity B: The median of set A

- (a) Quantity B is greater. (b) Quantity A is greater.
(c) The relationship cannot be determined (d) The two quantities are equal.

Answer: a

Explanation:

Begin by reordering the set in numerical order:

Set A = [-10, 4, 2, -14, -2]

Then becomes

Set A = [-14, -10, -2, 2, 4]

Since there are an odd number of values, the median is the middle value.

Quantity B: -2

Now, to find the arithmetic mean, take the sum of values divided by the total number of values.

$$\frac{-14 - 10 - 2 + 2 + 4}{5}$$

Quantity A: -4

Question 42**The arithmetic mean of $2-x, 3x^2, 7-15x, x^2-8x+23$ is -1****Quantity A: 3****Quantity B: The median of 2, x, 1, 4, 10, 8,, 2, x, 1, 4, 10, 8**

- (a) Quantity B is greater. (b) Quantity A is greater
 (c) The relationship cannot be determined (d) The two quantities are equal.

Answer: a**Explanation:**

X is an unknown value, but it can be found given what we know about the mean of the set $2-x, 3x^2, 7-15x, x^2-8x+23$:

$$\frac{(2-x) + (3x^2) + (7-15x) + (x^2-8x+23)}{4} = -1$$

$$4x^2 - 24x + 32 = -4$$

$$x^2 - 6x + 8 = -1$$

$$x^2 - 6x + 9 = 0$$

$$(X-3)(X-3)=0$$

$$X=3$$

Now, Quantity B: is out of order; arrange in numerically:

1, 2, x=3, 4, 8, 10

Since, there is even number of values; the median is the mean of the two middle most values:

$$\text{Quantity B: } \frac{3+4}{2} = 3.5$$

$$3+4=3.5$$

Question 43**Bill runs for 30 minutes at 8 mph and then runs for 15 minutes at 13 mph. what was his average speed during his entire run?**

- (a) 10 mph (b) $9\frac{2}{3}$ mph
 (c) 11 mph (d) $10\frac{1}{2}$ mph

Answer: b**Explanation:**

Rate = distance/time.

Find the distance for each individual segment of the run (4 miles and 3.25 miles.). Then add total distance and divide by total time to get the average rate, while making sure the units are compatible (miles per hour not miles per minute), which means the total 45 minute run time needs to be converted to 0.75 of an hour ; therefore (4 miles + 3.25miles/0.75 hour) is the final answer.

Question 44**Find the mode for the following data.**

Age	0-6	6-12	12-18	18-24	24-30	30-36	36-42
Frequency	6	11	25	35	18	12	6

- (a) 20.22 (b) 19.47
(c) 21.12 (d) 20.14

Answer: a

Explanation:

Since, maximum class frequency is 35, so the mode class is 18-24.

$$\text{Now, Mode} = L + \frac{f_1 - f_0}{2f_1 - f_0 - f_2} \times h$$

$$18 + \left(\frac{35 - 25}{2 \times 35 - 25 - 18} \right) \times 6$$

$$= 18 + 2.22 = 20.22$$

Question 45

Find the median for the following distribution of workers.

Daily wages	No. of workers	Daily wages	No. of workers
1-3	6	9-11	21
3-5	53	11-13	16
5-7	85	13-15	4
7-9	86	15-17	4

- (a) 7.14 (b) 6.84
(c) 5.92 (d) 5.57

Answer: b

Explanation:

Daily wages	No. of workers	Cumulative frequency (cf)
1-3	6	6
3-5	53	59
5-7	85	144
7-9	86	230
9-11	21	251
11-13	16	267
13-15	4	271
15-17	4	275

Here, $n = 275$

$$\frac{n}{2} = 137.5$$

Median class 5-7

$$\text{Median} = l + \left(\frac{\frac{n}{2} - c.f.}{f} \right) \times h$$

$$= 5 + \left(\frac{137.5 - 59}{85} \right) \times 2 = 5 + \frac{78.5}{85} \times 2$$

$$= 5 + 1.84$$

$$= 6.84$$

Question 46

In an examination of 675 candidates of maximum marks 100 the examiner supplied the following information.

Marks obtained	No. of candidates
Less than 10%	7
Less than 20%	39

Less than 30%	95
Less than 40%	201
Less than 50%	381
Less than 60%	545
Less than 70%	631
Less than 80%	675

Calculated median and mode respectively of the percentage marks obtained.

(a) 47, 58, 46, 33

(b) 49, 12, 48, 22

(c) 45, 24, 46, 22

(d) 47.58, 48.22

Answer: d

Explanation:

Marks (fi)	cf	Frequency
0-10	7	7
10-20	39	32
20-30	95	56
30-40	201	106
40-50	381	180
50-60	545	164
60-70	631	86
70-80	675	44

Here, $n = 675$

$$\frac{n}{2} = 337.5$$

So, median class 40-50

$$\text{Median} = l + \left(\frac{\frac{n}{2} - c.f.}{f} \right) \times h$$

$$40 + 7.58 = 47.58$$

Now, maximum frequency is 180

So modal class is 40-50

$$\text{Modes} = l + \left(\frac{f_1 - f_0}{2f_1 - f_0 - f_2} \right) \times h$$

$$40 + \left(\frac{180 - 106}{2 \times 180 - 106 - 164} \right) \times 10$$

$$40 + \frac{74}{90} \times 10 = 40 + 8.22 = 48.22$$

Question 47

Find the mean, median and mode of the following data.

Classes	0-20	20-40	40-60	60-80	80-100	100-120	120-140
Frequency	6	8	10	12	6	5	3

(a) 88

(b) 60

(c) 65

(d) 100

Answer: C

Explanation:

Class	(xi)	Frequency (fi)	xifi	Cumulative frequency (cf)
0-20	10	6	60	6
20-40	30	8	240	14

40-60	50	10	500	24
60-80	70	12	840	36
80-100	90	6	540	42
100-120	110	5	550	47
120-140	130	3	390	50
Total		$\Sigma fi = 50$	$\Sigma fixi = 3120$	

$$\text{Mean} = \frac{\Sigma fixi}{\Sigma fi}$$

$$= \frac{3120}{50} = 62.4$$

$$n = 50, \frac{n}{2} = 25$$

Median class is 60-80

$$\text{Median} = l + \frac{\left(\frac{n}{2} - c.f.\right)}{f} \times h$$

$$= 60 + \left(\frac{25-24}{12}\right) \times 20$$

$$= 60 + 1.67$$

Maximum frequency is 12, so modal class is 60-80

$$\text{Mode} = l + \left(\frac{f_1 - f_0}{2f_1 - f_0 - f_2}\right) \times h$$

$$60 + \left(\frac{12-10}{2 \times 12 - 10 - 6}\right) \times 20$$

$$60 + 5 = 65$$

Question 48

The mean of 1, 3, 4, 5, 7, 4 is m. The numbers 3, 2, 2, 4, 3, 3, p have mean m^{-1} and median q. Then, $p + q =$

- (a) 4 (b) 5
(c) 6 (d) 7

Answer: d

Explanation:

Mean of 1, 3, 4, 5, 7 and 4 is m.

$$\rightarrow \frac{1+3+4+5+7+4}{6} = m$$

$$M = 4$$

Now, mean of 3, 2, 2, 4, 3, 3 and p is m^{-1}

$$\frac{3+2+2+4+3+3+p}{6} = 3$$

$$(\because m = 4) \rightarrow 17 + p = 21$$

$$\rightarrow p = 4$$

Arranging 3, 2, 2, 4, 3, 3 and 4 in ascending order, we get 2, 2, 3, 3, 3, 4, 4

$$\therefore \text{Median (q)} = n\left(\frac{7+1}{2}\right)^{\text{th}} \text{ term} - 4^{\text{th}} \text{ term} = 3$$

$$\therefore p + q = 4 + 3 = 7$$

Question 49

The mean of six numbers is 21. If one number is excluded, then their mean is 19, the excluded number is ____.

- (a) 31 (b) 26
(c) 28 (d) 25

Answer: a

Explanation:

Let the excluded number be x and the sum of rest of numbers be y . then, $21 = \frac{x+y}{6}$

$$\rightarrow 126 = x + y$$

$$19 = \frac{y}{5}$$

$$\rightarrow y = 95$$

\therefore From (i)

$$x = 31$$

Question 50

If 7, 2, 9, and 5 occur with frequencies 2, 3, 6 and 4 respectively, then the arithmetic mean is - ____.

(a) 6.25

(b) 6.75

(c) 6.27

(d) 6.42

Answer: c

Explanation:

$$\text{Arithmetic mean} = \frac{x_1f_1 + x_2f_2 + \dots + x_n f_n}{f_1 + f_2 + \dots + f_n}$$

$$\frac{(7 \times 2) + (2 \times 3) + (9 \times 6) + (5 \times 4)}{2 + 3 + 6 + 4}$$

$$\frac{14 + 6 + 54 + 20}{15} = \frac{94}{15} = 6.27$$

Question 51

Find n such that $\frac{a^{n+1} + b^{n+1}}{a^n + b^n}$ may be the geometric mean between a and b :

(a) $\frac{1}{2}$

(b) 1

(c) $\frac{-1}{2}$

(d) 0

Answer: c

Explanation:

We know that geometric mean between a & b is a & $b = \sqrt{ab}$

It is given that

$$\text{G.M. between } a \text{ \& } b = \frac{a^{n+1} + b^{n+1}}{a^n + b^n}$$

$$\sqrt{ab} = \frac{a^{n+1} + b^{n+1}}{a^n + b^n}$$

$$ab^{\frac{1}{2}} = \frac{a^{n+1} + b^{n+1}}{a^n + b^n}$$

$$(ab)^{\frac{1}{2}}(a^n + b^n) = a^{n+1} + b^{n+1}$$

$$a^{\frac{1}{2}} b^{\frac{1}{2}} (a^n + b^n) = a^{n+1} + b^{n+1}$$

$$\frac{1}{a^{\frac{1}{2}}} + n = \frac{b^n + \frac{1}{2} \left[\frac{1}{b^{\frac{1}{2}}} - \frac{1}{a^{\frac{1}{2}}} \right]}{\frac{1}{b^{\frac{1}{2}}} - \frac{1}{a^{\frac{1}{2}}}}$$

$$\frac{1}{a^{\frac{1}{2}}} + n = 1$$

$$\left(\frac{a}{b}\right)^{\frac{1}{2} + n} = \left(\frac{a}{b}\right)^0$$

Comparing power

$$\frac{1}{2} + n = 0$$

$$n = -\frac{1}{2}$$

Question 52

What is the mode of 10, 2, 8, 6, 7, 8, 9, 10, 10, 11 and 10?

- (a) 10 (b) 12
(c) 14 (d) 8

Answer: a

Explanation:

Mode = observation with the highest frequency = 10

Question 52

The mean of the marks in statistics of 100 students in class x was 72. The mean of marks for boys was 75, while their number was 70. What is the mean of marks of girls in the class?

- (a) 35 (b) 65
(c) 68 (d) 86

Answer: b

Explanation:

Total marks of boys

Total number of girls

$$\frac{100 \times 72 - 75 \times 70}{30} = \frac{7200 - 5250}{30}$$

$$\frac{1950}{30} = 65$$

Question 53

Which of the following is true about the mode of a given data?

- (a) It may or may not exist for a Given data. (b) It is always unique.
(c) It is very difficult to compute Mode. (d) We cannot calculate mode without The empirical formula.

Answer: a

Explanation:

Mode of a given data may or may not exist sometimes.

$$\text{Range} = 22 - 6 = 16$$

Question 54

The A.M. of 12 observations is 15. If an observation 20 is removed, what is the arithmetic mean of the remaining observations?

- (a) 14.5 (b) 13
(c) 15 (d) 13.5

Answer: a

Explanation:

The A.M. of 12 observations is 15.

$$\rightarrow \text{Sum of 12 observations} = 12 \times 15 = 180$$

An observation 20 is removed

$$\rightarrow \text{Mean of the remaining observations}$$

$$= \frac{180 - 20}{(12 - 1)} = \frac{160}{11} = 14.5$$

Question 55

If for a given data median is 125.6 and mean is 128, find mode.

For more Info Visit - www.KITest.in

- (a) 120.8 (b) 128.0
(c) 108.2 (d) 180.2

Answer: a

Explanation:

$$\begin{aligned} \text{Given median} &= 125.6 \text{ and mean} = 128. \text{ Mode} = 3 \text{ Median} - 2 \text{ Mean} \\ &= (3 \times 125.6) - (2 \times 128) \\ &= 376.8 - 256 \\ &= 120.8 \end{aligned}$$

Question 56

What is the arithmetic mean of $a+2$, a and $a-2$?

- (a) $a+2$ (b) a
(c) $a-2$ (d) $3a$

Answer: b

Explanation:

$$\text{Mean} = \frac{a+2+a+a-2}{3} = \frac{3a}{3} = a$$

Question 57

Which of the following is not a measure of central tendency?

- (a) Mean (b) Median
(c) Mode (d) Standard deviation

Answer: d

Explanation:

Mean, median and mode are the measures of central tendency.

UNIT II: DISPERSION

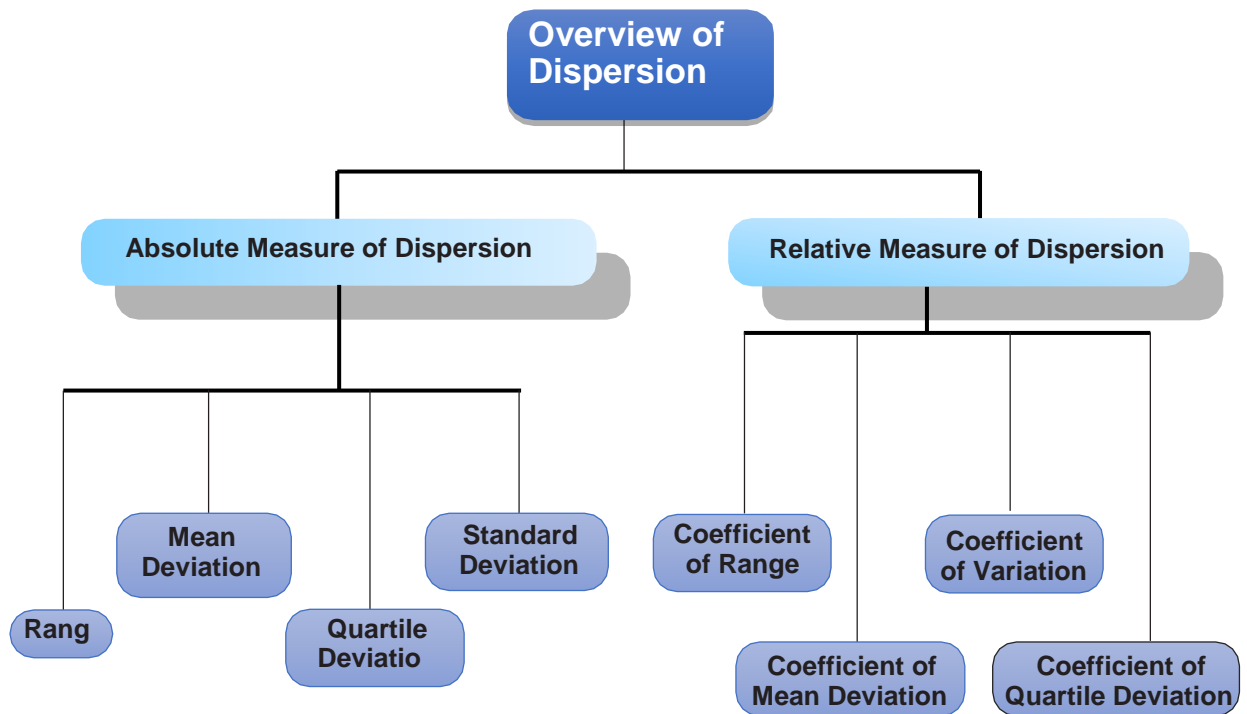

DISPERSION

The amount of deviation of the observations, usually, from an appropriate measure of central tendency. Two distributions may be identical in respect of its first important characteristic i.e. central tendency and yet they may differ on account of scatterness.

CLASSIFICATION OF DISPERSION

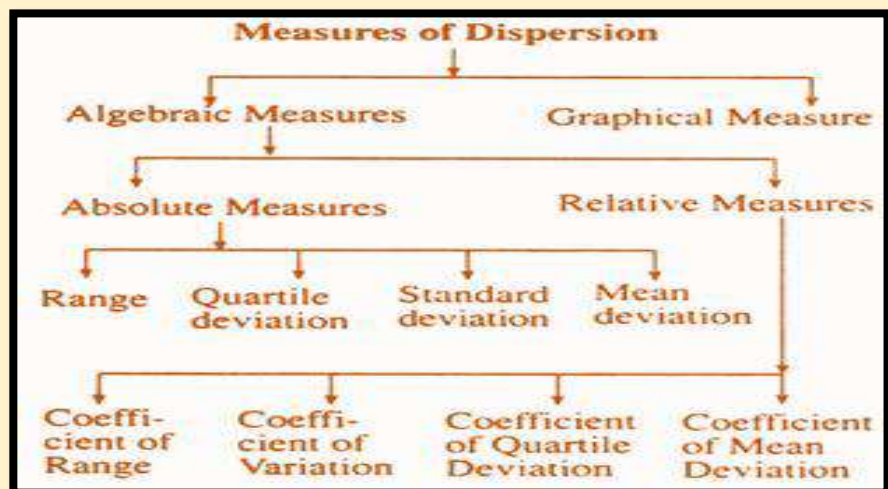

$$\text{Coefficient of range} = \frac{96-50}{96+50} \times 100$$

$$= 31.51$$

Question 2

What is the coefficient of range for the following distribution of weights?

Weights in kgs:	50-54	55-59	60-64	65-69	70-74
No. of students	12	18	23	10	3

- (a) 20 (b) 21
(c) 20.16 (d) 40.34

Answer: c

Explanation:

The lowest class boundary is 49.50 kgs. And the highest class boundary is 74.50 kgs. Thus we have

$$\text{Range} = 74.50 \text{ kgs} - 49.50 \text{ kgs}$$

$$= 25 \text{ kgs.}$$

$$\text{Coefficient of range} = \frac{74.50-49.50}{74.50+49.50} \times 100$$

$$= \frac{25}{124} \times 100$$

$$= 20.16$$

Question 3

Anubhav scored 85, 91, 88, 78, 85 for a series of exams. Calculate the mean deviation for his test scores?

- (a) 3.28 (b) 5.78
(c) 6.89 (d) None

Answer: a

Explanation:

Given test score; 85, 91, 88, 78, 85

$$\text{Mean} = \frac{(85+91+88+78+85)}{5} = 85.4$$

Subtracting mean from each score:

x	$x_i - \bar{x}$	$x_i - \bar{x}$
85	-0.4	0.4
91	5.6	5.6
88	2.6	2.6
78	-7.4	7.4
85	-0.4	0.4

$$\text{Mean deviations} = \frac{16.4}{5} = 3.28$$

Question 4

The wheat production (in kg) of 220 acres is given as: 1120, 1240, 1320, 1040, 1080, 1200, 1440, 1360, 1680, 1730, 1785, 1342, 1960, 1880, 1755, 1720, 1600, 1470, 1750, and 1885. Find the quartile deviation

- (a) 246.875 (b) 246
(c) 246.89 (d) 175

For more Info Visit - www.KITest.in

Answer: a**Explanation:**

After arranging the observations in ascending order, we get
1040, 1080, 1120, 1200, 1240, 1320, 1342, 1360, 1440, 1470, 1600, 1680, 1720, 1730, 1750,
1755, 1785, 1880, 1885, 1960.

$$Q_1 = \text{Value of } \left(\frac{n+1}{4}\right) \text{th item}$$

$$= \text{Value of } \left(\frac{20+1}{4}\right) \text{th}$$

$$= \text{Value of } (5.25) \text{th item}$$

$$= 5^{\text{th}} \text{ item} + 0.25(6^{\text{th}} \text{ item} - 5^{\text{th}} \text{ item}) = 1240 + 0.25(1320 - 1240)$$

$$Q_1 = 1240 + 20 = 1260$$

$$Q_3 = \text{value of } 3\left(\frac{n+1}{4}\right) \text{th item}$$

$$= \text{value of } 3\left(\frac{20+1}{4}\right) \text{th item}$$

$$= \text{value of } (15.75) \text{th item} = 15^{\text{th}} \text{ item} + 0.75(16^{\text{th}} \text{ item} - 15^{\text{th}} \text{ item}) = 1750$$

$$Q_3 = 1750 + 3.75 = 1753.75$$

$$Q. D. = \frac{Q_3 - Q_1}{2} = \frac{1753.75 - 1260}{2} = \frac{493.75}{2}$$

$$= 246.875$$
Question 5**Compute coefficient of variation from the following data:**

Age :	under 10	under 20	under 30	under 40	under 50	under 60
No. of persons dying:	10	18	30	45	60	80

(a) 48.83

(b) 89.88

(c) 756.34

(d) None

Answer: a**Explanation:**

Age in years class interval	No. of persons dying (f_i)	Mid value (x_i)	$d_i = x_i - 25$ 10	$f_i d_i$	$f_i d_i^2$
0-10	10	5	-2	-20	40
10-20	18-10=8	15	-1	-8	8
20-30	30-18=12	25	0	0	0
30-40	45-30=15	35	1	15	15
40-50	60-45=15	45	2	30	60
50-60	80-60=20	55	3	60	180
Total	80	-	-	77	303

The AM is given by:

$$\bar{x} = A + \frac{\sum f_i d_i}{N} \times C$$

$$= 25 \left(\frac{77 \times 10}{80} \right) \text{ years}$$

$$= 34.63 \text{ years}$$

$$CV = \frac{S}{\bar{x}} \times 100$$

The standard deviation is

$$\sqrt{\frac{\sum f_i d_i^2}{N} - \left[\frac{\sum f_i d_i}{N} \right]^2} \times C$$

$$\sqrt{\frac{303}{80} - \left[\frac{77}{80}\right]^2} \times 10 \text{ years}$$

$$\sqrt{3.79 - 0.93} \times 10 \text{ year}$$

$$= 16.91 \text{ years}$$

Thus the coefficient of variation is given by

$$= \frac{16.91}{34.63} \times 100$$

$$= 48.83$$

Question 6

What is the mean deviation about mean for the following numbers? 5, 8, 10, 10, 12, 9.

(a) 1.74

(b) 1.67

(c) 1.87

(d) 1.47

Answer: b

Explanation:

The mean is given by

$$\bar{X} = \frac{5+8+10+10+12+9}{6}$$

$$= 9$$

Computation of MD about AM

X_i	$X_i - \bar{X}$
5	4
8	1
10	1
10	1
12	3
9	0
Total	10

Thus mean deviation about mean is given by

$$X_i - \bar{X} = \frac{\sum 10}{6} = 1.67$$

Question 7

From the above data calculate coefficient of mean deviation

(a) 12.45

(b) 123

(c) 989

(d) None

Answer: a

Explanation:

$$\text{Coefficient of mean deviation} = \frac{\text{MD about Median}}{\text{Median}} \times 100$$

$$\frac{8714.28}{70000} \times 100$$

$$= 12.4$$

Question 8

For a group of 60 boy5 students, the mean and SD of stats. Marks are 45 and 2 respectively. The same figures for a group of 40 girl students are 55 and 3 respectively.

What is the SD of marks if the two groups are pooled together?

(a) 5.44

(b) 5.48

(c) 49

(d) 3

Answer: c

Explanation:

$$X = \frac{n_1x_1 + n_2x_2}{n_1 + n_2}$$

$$\frac{60 \times 45 + 40 \times 55}{60 + 40} = 49$$

Question 9

From the above questions and expression find standard deviation of marks

- (a) 5.44 (b) 5.48
(c) 30 (d) 3

Answer: b

Explanation:

$$d_1 = X_1 - X = 45 - 49 = -4$$

$$S = \sqrt{\frac{n_1s_1^2 + n_2s_2^2 + n_1d_1^2 + n_2d_2^2}{n_1 + n_2}}$$

$$d_1 = X_1 - X = 55 - 49 = 6$$

$$\sqrt{\frac{60 \times 2^2 + 40 \times 3^2 + 60 \times (-4)^2 + 40 \times 6^2}{60 + 40}}$$

$$\sqrt{30} = 5.48$$

Question 10

Calculate the mean deviation about median for the following data

Class	0-10	10-20	20-30	30-40	40-50	50-60
Frequency	6	7	15	$\frac{1}{6}$	4	2

- (a) 10.16 (b) 30.69
(c) 28 (d) 30

Answer: a

Explanation:

Class	Frequency	Cumulative frequency	Mid - point x_i
0-10	6	6	5
10-20	7	7 + 6 = 13	15
20-30	15	13 + 15 = 28	25
30-40	16	28 + 16 = 44	35
40-50	4	44 + 4 = 48	45
50-60	2	48 + 2 = 50	55
	50		

$$N \sum f_i = 50$$

Median Class $\left(\frac{N}{2}\right)^{th}$ term

$\left(\frac{50}{2}\right)^{th}$ term

25th

In above data cumulative frequency of class 20-30 is 28 which is slightly greater than 25.

∴ Median class = 20 - 30

$$\text{Median} = l + \frac{\frac{N}{2} - C}{f} \times h$$

Where,

L = Lower limits of median class

N = Sum of frequencies

F = frequency of median class

C = Cumulative frequency of class before median class

Here, $l = 20$, $N = 50$, $C = 13$, $h = 10$, $f = 15$

$$\text{Median} = l + \frac{\frac{N}{2} - C}{f} \times h$$

$$20 + \frac{\frac{50}{2} - 13}{15} \times 10$$

$$20 + \frac{12}{15} \times 10$$

$$20 + 8 = 28$$

Finding mean deviations about Median = $\frac{\sum f_i |x_i - M|}{\sum f_i}$

Class	Frequency	Cumulative frequency	Mid - point x_i	$ x_i - M $	$f_i x_i - M $
0-10	6	6	5	$ 5 - 28 = 23$	$6 \times 23 = 138$
10-20	7	$7+6 = 13$	15	$ 15 - 28 = 13$	$7 \times 13 = 91$
20-30	15	$13+15 = 28$	25	$ 25 - 28 = 3$	$15 \times 3 = 45$
30-40	16	$28+16=44$	35	$ 35 - 28 = 7$	$16 \times 7 = 112$
40-50	4	$44+4=48$	45	$ 45 - 28 = 17$	$4 \times 17 = 68$
50-60	2	$48+2=50$	55	$ 55 - 28 = 27$	$2 \times 27 = 54$
	$\sum f_i = 50$			$\sum f_i x_i - M $	508

$$\sum f_i = 50 \text{ \& } |x_i - M| = 508$$

$$\therefore \text{Mean deviation (M)} = \frac{\sum f_i |x_i - M|}{\sum f_i}$$

$$\frac{508}{50} = 10.16$$

Question 11

5 students obtained following marks in statistics: 20, 35, 25, 30, 15 find out range and coefficient of range.

(a) 20, 0.4

(b) 20, 0.5

(c) 30, 10

(d) 30, 5

Answer: a

Explanation:

Here,

Highest value (H) = 35

Lowest value (L) = 15

Range = Highest value - Lowest value

i.e. $R = H - L$

Substituting the given values in the formula

$$R = 35 - 15 = 20$$

Coefficient of range is as follows:

$$CR = \frac{H-L}{H+L}$$

$$\text{Or, } CR = \frac{35-15}{35+15}$$

$$= \frac{20}{50}$$

$$CR = 0.4$$

Hence, the range (R) of the above data is 20 and coefficient of Range (CR) is 0.4

Question 12

Prices of shares of a company were not as under from Monday through Saturday. Find out range and the coefficient of range.

Day	Mon.	Tues.	Wed.	Thu.	Fri	Sat.
Price	200	210	208	160	220	250

(a) 20, 0.4

(b) 90, 0.22

(c) 30, 0.65

(d) 30, 5.69

Answer: b

Explanation:

Here,

Highest value among the prices of shares =

250 Lowest value among the prices of shares = 160

Range (R) = Highest value (H) – Lowest value (L) or, R = 250-160

$$R = 90$$

$$\text{Coefficient of Range (CR)} = \frac{H-L}{H+L}$$

$$\text{Or, CR} = \frac{250-160}{250+160}$$

$$= \frac{90}{410}$$

$$CR = 0.219 \text{ or } 0.22 \text{ (Approx.)}$$

Question 13

You know share market is going bullish during the last several months. Collect weekly data on the share price of any two important industries during the past six months.

Calculate the range of share prices. Comment on how volatile is the share prices.

(a) Tata motors shares are more volatile as compared to the prices of Reliance shares.

(b) Tata motors shares are less volatile as compared to the prices of Reliance shares.

(c) Tata motors shares are equal as a To the prices of Reliance shares.

(d) None of these

Answer: b

Explanation:

Month	Price of shares Tata Motors	Price of shares Reliance
Oct.	325	913.35
Nov.	397	900.25
Dec.	405	750.90
Jan.	415	780.70
Feb.	420	799.25
Mar.	388	850.35

For TATA Motors Highest Value = 420 Lowest Value = 325

Range (R) = Highest Value (H) – Lowest Value (L) or, R₁ = 420-325

$$R_1 = 95$$

$$\text{Coefficient of Range (CR)} = \frac{H-L}{H+L}$$

For more Info Visit - www.KITest.in

$$\text{Or, Cr} = \frac{420-325}{420+325}$$

$$= \frac{95}{745} = 0.127$$

For Reliance

Highest Value = 913.35

Lowest value = 750.90

Range (R) = Highest Value (H) – lowest Value (L) or, $R_2 = 913.25 - 750.90$

$R_2 = 162.45$

Coefficient of Range (CR) = $\frac{H-L}{H+L}$

$$\text{CR} = \frac{913.35-750.90}{913.35+750.90}$$

$$= \frac{162.45}{1664.25} = 0.097$$

From the above results we can observe that the price of the Tata Motors shares is less volatile as compared to the prices of Reliance shares.

Question14

Calculate range and the coefficient of range of the following series:

Marks	10	20	30	40	50	60	70
No. of students	15	18	25	30	16	10	9

(a) 20,0.4

(b) 20,0.5

(c) 60,0.75

(d) 30,5

Answer: c

Explanation:

Here,

Highest value = 70

Lowest value = 10

Range (R) = Highest value (H) – Lowest Value (L)

$$= 70 - 10$$

$$= 60$$

Coefficient of Range (CR) = $\frac{H-L}{H+L}$

$$\text{CR} = \frac{70-10}{70+10} = \frac{60}{80} = 0.75$$

Hence, the Range (R) of the above series is 60 and coefficient of Range (CR) is 0.75

Question15

Find the variance of the following data: 6, 8, 10, 12, 14, 16, 18, 20, 22, 24.

(a) 33

(b) 15

(c) 10

(d) 14

Answer: a

Explanation:

x_i	$d_i = \frac{x_i - 14}{2}$	$x_i - x$	$(x_i - x)^2$
6	$\frac{6 - 14}{2} = -4$	$6 - 15 = -9$	$(-9)^2 = 81$
8	$\frac{8 - 14}{2} = -3$	$8 - 15 = -7$	$(-7)^2 = 49$

10	$\frac{10 - 14}{2} = -2$	$10 - 15 = -5$	$(-5)^2 = 25$
12	$\frac{12 - 14}{2} = -1$	$12 - 15 = -3$	$(-3)^2 = 9$
14	$\frac{14 - 14}{2} = 0$	$14 - 15 = -1$	$(-1)^2 = 1$
16	$\frac{16 - 14}{2} = 1$	$16 - 15 = 1$	$(1)^2 = 1$
18	$\frac{18 - 14}{2} = 2$	$18 - 15 = 3$	$(3)^2 = 9$
20	$\frac{20 - 14}{2} = 3$	$20 - 15 = 5$	$(5)^2 = 25$
22	$\frac{22 - 14}{2} = 4$	$22 - 15 = 7$	$(7)^2 = 49$
24	$\frac{24 - 14}{2} = 5$	$24 - 15 = 9$	$(9)^2 = 81$
	$\sum_{1}^{10} d_i = 5$		$\sum_{1}^{10} (x_i - x)^2 = 330$

Mean $\bar{X} =$ assumed mean $\frac{\sum_{1}^{10} x_i}{n} \times h$

Where a = assumed mean = 14

$$d_i = \frac{x_i - a}{h}$$

h = class width = 8 - 6 = 2

n = number of observation = 10

$$\text{Mean } \bar{X} = 14 + \frac{5}{10} \times 2 = 15$$

$$\text{Variance } (O^2) = \frac{1}{n} \sum (x_i - \bar{X})^2$$

$$\frac{1}{10} \times 330$$

33

Question 16

Find the standard deviation of the following data:

Class	30-40	40-50	50-60	60-70	70-80	80-90	90-100
Frequency	3	7	12	15	8	3	2

(a) 14

(b) 50

(c) 62

(d) 14.17

Answer: d

Explanation:

Class	Frequency (f_i)	Mid - point (x_i)	$f_i x_i$
30-40	3	35	$35 \times 3 = 105$
40-50	7	45	$45 \times 7 = 315$
50-60	12	55	$55 \times 12 = 660$
60-70	15	65	$65 \times 15 = 975$
70-80	8	75	$75 \times 8 = 600$

80-90	3	85	$85 \times 3 = 255$
90-100	2	95	$95 \times 2 = 190$
	$\sum f_i = 50$		$\sum f_i x_i = 3100$

$$\sum f_i x_i = 3100$$

$$\sum f_i = 50$$

$$\text{Mean } \bar{X} = \frac{\sum f_i x_i}{\sum f_i}$$

$$\frac{3100}{50} = 62$$

$$\text{Variance } (O^2) = \frac{1}{n} \sum (x_i - \bar{X})^2$$

$$\frac{1}{50} \times 10050 = 201$$

$$\text{Standard deviation } (O) = \sqrt{201}$$

$$(O) = 14.17$$

Question17

Estimate coefficient of quartile deviation of the following data:

Sr. No.	1	2	3	4	5	6	7	8	9	10	11
Data	8	9	11	12	13	17	20	21	23	25	27

(a) 3.53

(b) 0.353

(c) 0.689

(d) 0.591

Answer: b

Explanation:

In order to find the quartile deviation in case of individual series, we need to find out the values of third quartile and first quartile using the following equations:

$$Q_1 = \text{size of } \left(\frac{N+1}{4}\right)^{\text{th}} \text{ item}$$

$$Q_1 = \text{size of } \left(\frac{11+1}{4}\right)^{\text{th}} \text{ item}$$

$$Q_1 = \text{size of 3th term}$$

$$Q_1 = 11$$

$$Q_3 = \text{size of } 3 \left(\frac{N+1}{4}\right)^{\text{th}} \text{ item}$$

$$Q_3 = \text{size of } 3 \left(\frac{11+1}{4}\right)^{\text{th}} \text{ item}$$

$$\text{Or, } Q_3 = \text{size of 9th term}$$

$$\text{Or, } Q_3 = 23$$

Calculating Quartile Deviation and Coefficient of Quartile Deviation:

$$\text{Quartile Deviation (Q.D.)} = \frac{Q_3 - Q_1}{2}$$

$$\text{Q.D.} = \frac{23 - 11}{2}$$

$$\text{Q.D.} = \frac{12}{2}$$

$$\text{Q.D.} = 6$$

$$\text{Coefficient of Quartile Deviation (C.Q.D.)} = \frac{Q_3 - Q_1}{Q_3 + Q_1} = \frac{23 - 11}{23 + 11} = \frac{12}{34} = 0.353$$

Question18

A measure of relative dispersion is given by the:

For more Info Visit - www.KITest.in

- (a) Co-efficient of variance (b) Standard deviation
(c) Quartile deviation (d) Variance

Answer: a

Explanation:

Co-efficient of variance: This term is used commonly to mean scatter, deviation, Fluctuation, Spread or variability of data. Relative Measures of Dispersion Relative measures of dispersion are also known as coefficient of dispersion are obtained as ratios or percentages.

Question19

The ___ is the easiest measure of dispersion to calculate.

Symbol	Symbol Name	Meaning / definitions
Var (X)	variance	variance of random variable X
σ^2	variance	variance of population values
std (X)	standard deviation	standard deviation of random variable X
σ_x	standard deviation	standard deviation value of random variable X

- (a) Standard Deviation (b) Range
(c) Mean absolute deviation (d) Variance

Answer: b

Explanation:

Range is basically the difference between the lowest and highest values.

Question20

Which of the following symbols represents the standard deviation of the population?

- (a) σ^2 (b) μ
(c) σ (d) \bar{X}

Answer: c

Explanation:

σ

Question21

The variance can never be

- (a) Larger than the standard deviation (b) Negative
(c) Smaller than the standard deviation (d) Zero

Answer: b

Explanation:

Sometimes (negative or positive number) squared is always a positive number, except zero squared which is still zero. Because the squared deviations are all positive numbers or zeroes, their smallest possible mean is zero. It can't be negative. This average of the squared deviations is in fact variance. Hence the variance can be negative.

Question22

The numerical value of the standard deviation can never be

- (a) Negative (b) Larger than the variance
(c) Zero (d) None

Answer: a

Explanation:

Standard deviation formula is computed using squares of the numbers. Square of a number cannot be negative. Hence standard deviation cannot be negative. Here $(x-\text{mean})$ is squared, so, this cannot be negative. N , number of terms cannot be negative, hence SD cannot be negative.

Question23

The description measure of dispersion that is based on the concept of a deviation about the mean is

- (a) The absolute value of the range
 (b) Range
 (c) Standard deviation
 (d) Inter quartile range

Answer: c

Explanation:

A measure of dispersion is a numerical value describing the amount of variability present in a data set. The standard deviation (SD) is the most commonly used measures of dispersion. With the SD you can measure dispersion relative to the scatter of the values about their mean.

Question24

When should measures of location and dispersion be computed from grouped data rather than from individual data values?

- (a) Whenever computer packages for descriptive statistics are unavailable
 (b) As much as possible since computations are easier
 (c) Only when the data are from a population
 (d) Only when individual data values are unavailable

Answer: d

Explanation:

Only when individual data values are unavailable should measures of location and dispersion be computed from grouped data rather than from individual data values.

Question25

Which information is false regarding Lorenz curve

- (a) The Lorenz curve devised by Dr. Max O. is a graphic method of studying Dispersion.
 (b) Used this technique to show employment of a group of people
 (c) The Lorenz curve always lies below the line of equal distribution, unless the distribution is uniform
 (d) The area between the line of equal distribution and the plotted curve gives the extent of inequality in the items. The larger the area, more is the inequality

Answer: b

Explanation:

A graph on which the cumulative percentage of total national income (or some other variable) is plotted against the cumulative percentage of the corresponding population (ranked in increasing size of share). The extent to which the curve saqs below a straight diagonal line indicates the degree of inequality of distribution.

Question25

Adding a constant to each value in a data set does not change the distance between values so the standard deviations remains

- (a) Constant
 (b) Vary
 (c) Vary with multiple of prime
 (d) None of these

Answer: a

Explanation:

For example, consider the following numbers
2,3,4,4,5,6,8,10 for this set odd data standard deviation would be

$$s = \sqrt{\frac{\sum_{i=1}^n (x_i - \bar{x})^2}{n-1}}$$

$$s = \sqrt{\frac{(2-5.25)^2 + (3-5.25)^2 + \dots + (10-5.25)^2}{8-1}}$$

$$s = 2.65922$$

If we were to add 5 to each value in this data set. The new set of values would be 7, 8, 9, 9, 10, 11, 13, 15

$$s = \sqrt{\frac{(7-10.25)^2 + (8-10.25)^2 + \dots + (15-10.25)^2}{8-1}}$$

$$s = 2.65922$$

As you can see the s.d. remains the same unless you multiply every value by a constant

PAST EXAMINATION QUESTIONS:

MAY 2018

Question1

If the variables x and z are so related that $z = ax + b$ for each $x = x_1$ where a and b are constant, then $\bar{Z} = a\bar{X} + b$

- (a) True (b) False
(c) Both (d) None

Answer: a

Explanation:

If the variable 'X' and 'Z' are so related that $Z = ax + b$ for each $x = x_1$ where a and b are constant then $Z = ax + b$ then it is true.

Question2

Relation between mean, median and mode is:

- (a) Mean-mode = 2 (mean - median) (b) Mean-median = 3(mean - mode)
(c) Mean-median = 2 (mean - mode) (d) Mean-mode = 3(mean- median)

Answer: d

Explanation:

We know that

$$\text{Mode} = 3 \text{ Median} - 2 \text{ Mean}$$

$$\text{Mode} - \text{Mean} = 3 \text{ Median} - 2 \text{ Mean} - \text{Mean}$$

$$\text{Mode} - \text{Mean} = 3 (\text{Median} - \text{Mean})$$

$$\text{Mode} - \text{Mean} = 3 (\text{Median} - \text{Mean})$$

Mean – Mode = 3 (Mean – Median)

Question3

$\frac{(Q_3-Q_1)}{(Q_3+Q_1)}$ is known as

- (a) Coefficient of Range (b) Coefficient of Q.D
(c) Coefficient of S.D (d) Coefficient of M.D

Answer: b

Explanation:

$$\text{Coefficient of Q.D} = \frac{(Q_3-Q_1)}{(Q_3+Q_1)}$$

Question4

If each item is reduced by 15 A. M is

- (a) Reduced by 15 (b) Increased by 15
(c) Reduced by 10 (d) None

Answer: a

Explanation:

If each item is reduced by 15 then new A.M. is reduced because the shifting of origin, the A.M. is changed.

Question5

For 899, 999, 391, 384, 390, 480, 760, 111, 240 Rank of m is

- (a) 2.75 (b) 8.25
(c) 5.5 (d) none

Answer: c

Explanation:

Write the terms in Ascending order 111, 240, 384, 391, 480, 590, 760, 899, 999.
Here No of observations (N) = 10

$$\begin{aligned} \text{Median } (m_e) &= \left[\frac{n+1}{2} \right]^{th} \text{ term} \\ &= \left[\frac{10+1}{2} \right]^{th} \text{ term} \\ &= 5.5^{th} \text{ term} \end{aligned}$$

$$\text{Rank of median } (m_e) = 5.5$$

Question 6

The average of a series of overlapping averages, each of which is based on a certain number of item within a series is known as:

- (a) Moving Average (b) Weighted average
(c) Simple average (d) None

Answer: a

Explanation:

The average of a series of overlapping averages, each of which is based on a certain number of items within a series is known as Moving Average.

Question 7

If the S.D. of the 1st n natural Nos. is $\sqrt{30}$. Then the value of n is

- (a) 19 (b) 20
(c) 21 (d) None

Answer: a**Explanation:**

S.D of first 'n' natural numbers

$$= \sqrt{\frac{n^2-1}{12}}$$

$$= \sqrt{30} = \sqrt{\frac{n^2-1}{12}}$$

On squaring both side $30 = \frac{n^2-1}{12}$

$$360 = n^2 - 1$$

$$n^2 = 360 + 1$$

$$n^2 = 361$$

$$n = \sqrt{361}$$

$$n = 19$$

Question 8

If the random variables x and v are related by $Y=2-3x$, then the SD of v is given by

- (a) 3 × SD of x (b) -3 × SD of x
(c) 9 × SD of x (d) 2 × SD of x

Answer: a**Explanation:**

Given equation

$$Y = 2 - 3x$$

$$3x + y - 2 = 0$$

$$b = \frac{-\text{coefficient of } x}{\text{coefficient of } y} = \frac{-3}{1} = -3$$

S.D of y = |b| S.D of x

$$= |-3|. \text{ SD of } x$$

$$3 \times \text{SD of } x$$

NOV 2018

Question 1

The median of the data 5, 6, 7, 7, 8, 9, 10, 11, 11, 12, 15, 18 and 19 is

- (a) 10.5 (b) 10

(c) 11

(d) 11.5

Answer: a**Explanation:**

Write the term is Ascending 5, 6, 7, 7, 8, 9, 10, 11, 11, 12, 15, 18 and 19

Here, No. of terms (N) = 14

$$\text{Median} = \frac{1}{2} \left[\left[\frac{N}{2} \right] \text{ term} + \left[\frac{n+1}{2} \right] \text{ term} \right]$$

$$\frac{1}{2} \left[\left[\frac{14}{2} \right] \text{ term} + \left[\frac{14+1}{2} \right] \text{ term} \right]$$

$$\frac{1}{2} [7\text{th term} + 8\text{th term}]$$

$$\frac{1}{2} [10+11]$$

$$\frac{1}{2} \times [21]$$

$$10.5$$

Question 2**The mean of 20 items of a data is 5 and if each item is multiplied by 3, then the new mean will be**

(a) 5

(b) 10

(c) 15

(d) 20

Answer: c**Explanation:**

By shifting the scale Mean is changed

New mean = K x original mean = 5

K = 3

New mean = 3 x 5

= 15

Question 3**The Geometric mean of 3, 6, 24, and 48 is**

(a) 8

(b) 12

(c) 24

(d) 6

Answer: b**Explanation:**

$$\text{G.M.} = (x_1 x_2 x_3 x_4)^{\frac{1}{4}} \quad \{\text{Here, } n = 4\}$$

$$(3 \times 6 \times 24 \times 48)^{\frac{1}{4}}$$

$$= 4\sqrt[4]{3 \times 6 \times 24 \times 48}$$

$$= 4^2 \sqrt[4]{3 \times 3 \times 2 \times 2 \times 2 \times 2 \times 3 \times 2 \times 2 \times 2 \times 2 \times 3}$$

$$= 2 \times 2 \times 3$$

$$= 12$$

Question 4

The Algebraic sum of the deviation of a set of values from their arithmetic mean is

- (a) >0 (b) $=0$
(c) <0 (d) None

Answer: b

Explanation:

The arithmetic sum of the deviation of a set of value from their A.M is always zero.

Question 5

Which one of the following is not a central tendency?

- (a) Mean Deviation (b) Arithmetic mean
(c) Median (d) Mode

Answer: a

Explanation:

M.D is not a central tendency.

Question 6

If the range of a set of values is 65 and maximum value in the set is 83, then the minimum value in the set is

- (a) 74 (b) 9
(c) 18 (d) None of the above

Answer: c

Explanation:

Maximum Value (L) = 83

Range (R) = 65

Minimum Value (S) = ?

Range (R) = L - S

$65 = 83 - S$

$S = 83 - 65$

$S = 18$

Question 7

If total frequencies of three series are 50, 60 and 90 and their means are 12, 15, and 20 respectively, then the mean of their composite series is

- (a) 16 (b) 15.5
(c) 16.5 (d) 14.5

Answer: c

Explanation:

$n_1 = 50$

$\bar{X}_1 = 12$

$n_2 = 60$

and

$\bar{X}_2 = 15$

$$n_3 = 90$$

$$\bar{X}_3 = 20$$

$$\text{Compared mean } \bar{X} = \frac{n_1\bar{X}_1 + n_2\bar{X}_2 + n_3\bar{X}_3}{n_1 + n_2 + n_3}$$

$$\frac{50 \times 12 + 60 \times 15 + 90 \times 20}{50 + 60 + 90}$$

$$\frac{600 + 900 + 1800}{200}$$

$$\frac{3300}{200} = 16.5$$

Question 8

If the variance of 5, 7, 9 and 11 is 4, then the coefficient of variation is:

- (a) 15 (b) 0.25
(c) 17 (d) 19

Answer: b

Explanation:

Variance of 5, 7, 9 and 11 is 4.

i.e. Variable = 4

$$\text{S.D (O)} = \sqrt{4} = 2$$

$$\text{Mean } (\bar{X}) = \frac{\sum x}{N} = \frac{5+7+9+11}{4} = \frac{32}{4} = 8$$

$$\text{CV} = \frac{\text{SD}}{\text{M}} = \frac{2}{8} = \frac{1}{4} = 0.25$$

Question 9

Standard deviation for the marks obtained by a student in test in mathematic (out of 50) as 30, 35, 25, 20, 15 is

- (a) 25 (b) $\sqrt{50}$
(c) $\sqrt{30}$ (d) 50

Answer: b

Explanation:

Given data's are

15, 20, 25, 30, 35

$$\text{Mean } (\bar{X}) = \frac{\sum X}{N} = \frac{15+20+25+30+35}{5} = \frac{125}{5} = 25$$

For S.D

x	\bar{X}	d = x - \bar{X}	d ²
15	25	-10	100
20	25	-5	25
25	25	0	0

30	25	5	25
35	25	10	100
N=5			$\sum d^2$ = 250

$$SD = \sqrt{\frac{\sum d^2}{N}} = \sqrt{\frac{250}{5}} = \sqrt{50}$$

Question10

If in a moderately skewed distribution, the values of mode and mean are 32.1 and 35.4 respectively, then the value of the median is

- (a) 34.3 (b) 33.3
(c) 34 (d) 33

Answer: a

Explanation:

Given

Mode = 32.1, Median = ?

Mean = 35.4

Mode = 3 Median - 2 Mean

32.1 = 3 Median - 2 × 35.4

32.1 = 3 Median - 70.8

Median = 32.1 + 70.8

Median $\frac{102.9}{3} = 34.3$

Question11

If the standard deviation for the marks obtained by a student in monthly test is 36. Then the variance is:

- (a) 7 (b) 5
(c) 8 (d) 11

X	f	F. x
2	3	6
4	2	8
6	3	18
10	1	10
P+5		2P + 10
N = 11	$\sum fx = 2P + 52$	

Answer: a

Explanation:

$$\bar{X} = \frac{\sum fx}{N} = \frac{2P+52}{11}$$

Given

$$\bar{X} = 6$$

$$\frac{6}{1} = \frac{2P+52}{11}$$

$$2P + 52 = 66$$

$$2P = 14$$

$$P = 7$$

MAY 2019

Question1

The AM of 15 observations is 9 and the AM of first 9 observations is 11 and the AM of remaining observation is

- | | |
|--------|-------|
| (a) 11 | (b) 6 |
| (c) 5 | (d) 9 |

Answer: b

Explanation:

$$15 \text{ OBSERVATION} = 9$$

$$9 \text{ OBSERVATION} = 11$$

$$\bar{x}_1 \text{ of } 15 = 9 = \frac{\sum x_1}{9} = 9$$

$$\bar{x}_2 \text{ of } 9 = 11 = \frac{\sum x_2}{9} = 11$$

$$\sum x_1 = 15 \times 9 = 135$$

$$\sum x_2 = 11 \times 9 = 99$$

$$\text{Remaining } \sum x_1 - \sum x_2 = 135 - 99 = 36$$

$$\bar{x}_{30} = \frac{36}{6} = 6$$

Question2

In a moderately skewed distribution, the values of mean & median are 12 & 18 respectively. The value of mode is

- | | |
|--------|--------|
| (a) 6 | (b) 12 |
| (c) 15 | (d) 30 |

Answer: d

Explanation:

$$\text{Mean} - \text{mode} = 3(\text{Mean} - \text{Median})$$

Put the value in this equation

$$= 12 - \text{mode} = 3(12-18)$$

$$= 30$$

Question3

Which of the following is positional average?

- (a) Median (b) GM
(c) HM (d) AM

Answer: a

Explanation:

There are two types of positional average: the median and the mode. The median is the average value of the series in which half values are less than the median and half the values are greater than the median. The mode, the second positional average, shows a higher frequency in the series 2.

Question4

For the distribution

X	1	2	3	4	5	6
F	6	9	10	14	12	8

The value of median is

- (a) 3.5 (b) 3
(c) 4 (d) 5

Answer: c

Explanation:

x	f	c f
1	6	6
2	9	15
3	10	25
4	14	39
5	12	51
6	8	59
Total	59	

$$\frac{N+1}{2} = 30$$

So Median be 4

Question5

For a symmetric distribution

- (a) Mean = Median = Mode (b) Mode = 3 Median - 2 Mean
(c) Mode = $\frac{1}{3}$ median = $\frac{1}{2}$ (d) None

Answer: a

Explanation:

In a symmetric distribution, the mean, mode and median all fall at the same point. The mode is the most common number and it matches with the highest peak (the "mode" here is the different from the "mode" in bimodal or unimodal, which refers to the number of peaks).

Question6

If $(\sigma^2) 100$ and coefficient of variation = 20% then $\bar{x} =$

- (a) 60 (b) 70
(c) 80 (d) 50

Answer: d

Explanation:

$\sigma^2 = \text{Variance}$

To find SD = σ

$$\text{SD} = \sqrt{100} = 10$$

$$\text{Coef. Of V} = \frac{\sigma}{x}$$

$$20 = \frac{10}{x} \times 100$$

$$\bar{x} = \frac{10}{20} \times 100$$

$$\bar{x} = 50$$

Question7

Coefficient of quartile deviation is $\frac{1}{4}$ then $\frac{Q_3}{Q_1}$ is

- (a) $\frac{5}{3}$ (b) $\frac{4}{3}$
(c) $\frac{3}{4}$ (d) $\frac{3}{5}$

Answer: a

Explanation:

$$\frac{1}{4} = \frac{Q_3 - Q_1}{Q_3 + Q_1}$$

Talking option a

$$Q_3 = 5 \text{ \& } Q_1 = 3$$

$$\frac{5-3}{5+3} = \frac{2}{8} = \frac{1}{4}$$

Question8

Standard deviation is _____ times of $\sqrt{MD \times QD}$

- (a) $\frac{2}{3}$ (b) $\frac{4}{5}$
(c) $\sqrt{\frac{15}{8}}$ (d) $\sqrt{\frac{8}{15}}$

Answer: c

Explanation:

$$\text{MD} = \frac{4}{5} \text{ SD}$$

$$4\text{SD} = 5\text{MD} = 6\text{QD}$$

$$SD = \frac{5}{4} MD = \frac{6}{4} QD$$

$$SD = \sqrt{\frac{5}{4} \times \frac{6}{4}} = \sqrt{\frac{30}{16}} = \sqrt{\frac{15}{8}}$$

Question9**Standard Deviation of first five natural numbers.**

(a) $\sqrt{\frac{n^2+1}{6}}$ (b) $\sqrt{\frac{n^2-1}{12}}$

(c) $\sqrt{\frac{n^2-1}{12}}$ (d) $\sqrt{\frac{n^2-1}{6}}$

Answer: b**Explanation:**

$$\text{Mean, } u = \frac{(1+2+3+\dots+n)}{n}$$

$$\therefore u = \frac{1}{2}(n+1)$$

$$\text{Variance, } \sigma^2 = \frac{\sum(x_i - u)^2}{n} = \frac{\sum x_i^2}{n} - u^2$$

$$\therefore \sigma^2 = \frac{\sum n^2}{n} - \frac{1}{2}(n+1)^2$$

$$\therefore \sigma^2 = \frac{1}{n} \frac{n(n+1)(2n+1)}{n} - \left(\frac{1}{2}(n+1)\right)^2$$

$$\therefore \sigma^2 = \frac{n^2-1}{12}$$

$$\text{Standard Deviation, S.D} = \sqrt{\sigma^2}$$

$$\therefore \text{S.D} = \sqrt{\frac{n^2-1}{12}}$$

Question10**The Q.D. of 6 numbers 15, 8, 36, 40, 38, 41 is equal to**

(a) 12.5 (b) 25

(c) 13.5 (d) 37

Answer: c**Explanation:**

$$Q_1 = \left(\frac{n+1}{2}\right)^{th} \text{ of } \left(\frac{6+1}{4}\right)^{th} \text{ of } \left(\frac{7}{4}\right)^{th} \text{ of } 1.75^{th}$$

$$8 + 0.75(15-8)$$

$$8 + 5.25$$

$$Q_1 = 13.25$$

$$Q_3 = 3\left(\frac{n+1}{2}\right)^{th} \text{ of } 3\left(\frac{n+1}{2}\right)^{th} \text{ of } 3 \times \frac{7}{4} = 3 \times 1.75 = 5.25$$

$$Q_3 = 5^{th} \text{ of } + 0.25(6^{th} - 5^{th})$$

$$40 + 0.25(41-40)$$

$$Q_3 = 40.25$$

$$QD = \frac{Q_3 - Q_1}{2} = \frac{40.25 - 13.25}{2}$$

13.5

NOV 2019

Question1

The approximate ratio of SD, MD, Q D is:

- (a) 3:4:5 (b) 2:3:4
(c) 15:12:10 (d) 5:6:7

Answer: c

Explanation:

(c) We know that

$$4SD = 5MD = 6QD$$

$$\text{Net } 4SD = 5MD = 6QD = K$$

So,

$$SD = \frac{K}{4}, MD = \frac{K}{5}; QD = \frac{K}{6}$$

Now, SD: MD: QD

$$\Rightarrow \frac{K}{4} : \frac{K}{5} : \frac{K}{6}$$

$$\Rightarrow \frac{30K}{120} : \frac{24K}{120} : \frac{20K}{120} \quad [\because \text{LCM OF } 4, 5, 6 \text{ is } 120]$$

$$\Rightarrow 30:24:20$$

$$\Rightarrow 15:12:10 \text{ so,}$$

$$SD:MD: QD = 15:12:10$$

Question2

The deviations are minimum when taken from:

- (a) Mean (b) Median
(c) Mode (d) None

Answer: b

Explanation:

(b) The sum of deviations are minimum when taken from median

$$\sum |x - \text{Mean}|$$

$$\sum |x - \text{Median}| \quad \{\text{Minimum}\}$$

$$\sum |x - \text{Mode}|$$

Question3

If the AM & GM of two numbers are 30 and 24 respectively. Find the no's

- (a) 12 and 24 (b) 48 and 12
(c) 30 and 30 (d) 40 and 20

Answer: b

Explanation:

(b) Let the two no's be a and b

$$AM = 30$$

$$GM = 24$$

$$\frac{a+b}{2} = 30$$

$$\sqrt{ab} = 24 \quad (-2)$$

$$a + b = 60$$

$$a = 60 - b \quad (-1)$$

put eq 1 in eq 2

$$\sqrt{(60 - b)b} = 24$$

(on squaring both sides)

$$(60 - b)b = 576$$

$$60b - b^2 = 576$$

$$b^2 - 60b + 576 = 0$$

$$b^2 - 48b - 12b + 576 = 0$$

$$b(b - 48) - 12(b - 48) = 0$$

$$(b-12)(b-48) = 0$$

$$b = 12 \quad \text{or} \quad b = 48$$

$$a = 60 - b \quad a = 60 - 48$$

$$a = 48 \quad a = 12$$

$$(12, 48) \quad \text{or} \quad (48, 12)$$

So the two no's are 48 and 12

After Method [Do by hit and trial]

i.e. try with the given options whether their AM is 30 and GM 24

Question4

Origin is shifted by 5, what will happen

(a) SD will increase by 5

(b) QD will increase by 5

(c) MD will increase by 5

(d) There will be no change

Answer: d

Explanation:

(d) SD is not affected of remains in changed by shifting of origin. So here if the origin is shifted by 5 there will be no change in SD.

Question5

Coefficient of variation is equal to:

$$(a) \frac{SD}{Mean}$$

$$(b) \frac{SD}{Mean} \times 100$$

$$(c) \frac{Mean}{SD} \times 100$$

$$(d) \frac{Mean}{SD}$$

Answer: b

Explanation:

(b) In probability theory and statistics the coefficient of variation also known as relative standard deviation is a standardized measure of dispersion of frequency distribution.

It is expressed as a percentage and defined as the ratio of SD and mean.

$$\text{SD so. Coefficient of variation} = \frac{\text{SD}}{\text{Mean}} \times 100$$

Question6

Find mode of the following data

3 - 6	6 - 9	9 - 12	12 - 15	15 - 18	18 - 21
2	5	10	23	21	12

(a) 14

(b) 15

(c) 16.5

(d) 14.6

Answer: d

Explanation:

(c) CI	f
3 - 6	2
6 - 9	5
9 - 12	10
12 - 15	23 × Modal class
15 - 18	21
18 - 21	12

Since 23 is the highest frequency, so 12 - 15 is the modal class.

So, $f_1 = 23$, $f_0 = 10$, $f_2 = 21$

$$L_1 = 12 \quad i = 3$$

$$\text{Mode} = L_1 + \frac{f_1 - f_0}{2f_1 - f_0 - f_2} \times i$$

$$= 12 + \frac{23 - 10}{2(23) - 10 - 21} \times 3$$

$$= 12 + \frac{13}{15} \times 3$$

$$= 12 + 2.599$$

$$= 14.59$$

$$= 14.6 \text{ (approx)}$$

Question7

Find SD of the following

1, 2, 3, 4, 5, 6, 7, 8, 9

(a) 2.58

(b) $\frac{60}{9}$

(c) $\frac{60}{3}$

(d) 3.20

Answer: a

Explanation:

$$(a) \text{SD} = \sqrt{\frac{\sum X^2}{N} - \left(\frac{\sum X}{N}\right)^2}$$

Here $N = 9$

$$x^2 = 1^2 + 2^2 + 3^2 + 4^2 + \dots + 9^2$$

$$= 285$$

$$\frac{\sum X}{N} = \frac{1+2+3+4+5+6+7+8+9}{9} = 5$$

Put in above formula,

$$SD = \sqrt{\frac{285}{9} - \frac{25}{1}}$$

$$SD = \frac{\sqrt{60}}{9}$$

$$SD = \sqrt{6.67}$$

$$SD = 2.58$$

Question8

If mean = 200 and variance = 80. Find coefficient of variation.

- (a) 2.56 (b) 4.47
(c) 32 (d) 0.32

Answer: b

Explanation:

(b) We know

$$CV = \frac{SD}{Mean} \times 100$$

$$CV = \sqrt{\frac{Variance}{Mean}} \times 100$$

$$SD = \sqrt{Variance}$$

$$CV = \sqrt{\frac{80}{200}} \times 100$$

$$CV = \sqrt{\frac{80}{2}}$$

$$CV = 4.47 \text{ (approx.)}$$

Question9

Which of the following is affected by shifting of scale.

- (a) SD (b) MD
(c) QD (d) None of these

Answer: a

Explanation:

(a) Since SD, MD, QD are measures of absolute dispersion, So, a change in scale neither affect SD nor MD and QD.

Question10

Histogram is used for to represent

- (a) Mode (b) Median
(c) Percentile (d) Quartile

Answer: a**Explanation:**

(a) Histogram is a graphical representation of grouped frequency distribution. It is used to locate mode. X – axis- class interval y-axis- frequency.

Question11**Coefficient of variation is 80. Mean is 20. Find variance:**

- (a) 640 (b) 256
(c) 16 (d) 250

Answer: b**Explanation:**

(b) We know,

$$\text{Coefficient of variation (CV)} = \frac{\text{SD}}{\text{Mean}} \times 100$$

Here mean = 20 ; CV = 80

$$80 = \frac{\text{S.D.}}{\text{Mean}} \times 100$$

$$\text{S.D.} = 16$$

$$\text{Variance} = (\text{S.D.})^2$$

$$\text{Variance} = (16)^2 = 256$$

Question12**Find the median of the following.**

CI	0 -10	10 -20	20 – 30	30 – 40	40 -50
f	2	3	4	5	6

- (a) 35 (b) 32
(c) 36 (d) 37.5

Answer: b**Explanation:**

CI	f	c.f
0-10	2	2
10-20	3	5
20-30	4	9
30-40	5	14
40-50	6	20

$$\sum f = 20$$

$$N = 20$$

So 30 – 40 is the median class

L, = 30 C =Pre. Cof. of median class

$$C \Rightarrow 9 \quad F \Rightarrow 5$$

$$\text{Median} = 4 + \frac{\left(\frac{N}{2} - c\right)}{f} \times i$$

$$= 30 + \left(\frac{10-9}{5}\right) \times 10$$

$$= 30+2$$

$$= 32$$

Question13**Difference between upper limit and lower limit of a class is known**

- (a) Range (b) Class mark
(c) Class size (d) Class boundary

Answer: c**Explanation:**

- (c) • Difference between upper limit and lower limit of class is class size.
• Range = Largest value - Smallest value
• Class mark = $\frac{(\text{Lowest Limit} + \text{Upper Limit})}{2}$
• Class boundary = Class interval of exclusive data series.

Question14**Find the mode of the following:**

0 - 10	10 - 20	20 - 30	30 - 40	40 - 50	50 - 60
7	14	22	34	20	19

- (a) 32 (b) 34.61
(c) 25.42 (d) 35

Answer: b**Explanation:**

CI	f
0 - 10	7
10 - 20	14
20 - 30	22
30 - 40	34
40 - 50	20
50 - 60	19

Since 34 is the highest frequency so, 30 - 40

$$F_1 = 34 \quad f_0 = 22 \quad f_2 = 20$$

$$i = 10$$

$$\text{Mode} = L_1 + \frac{f_1 - f_0 \times i}{2f_1 - f_0 - f_2}$$

$$= 30 + \frac{(34-22)}{2 \times 34 - 22 - 20} \times 10$$

$$= 30 + \frac{12}{26} \times 10$$

$$= 34.61$$

Question15

Find the median of the following:

CI	0 - 10	10 - 20	20 - 30	30 - 40	40 - 50
f	5	15	28	10	2

- (a) 10.57 (b) 23.57
(c) 25 (d) None

Answer: b

Explanation:

CI	f	c.f
0 - 10	5	5
10 - 20	15	20
20 - 30	28	48*
30 - 40	10	58
40 - 50	2	60

$$\sum f = 60$$

$$\frac{N}{2} = \frac{60}{2} = 30$$

So 20 - 30 is the median class

$$L_1 = 20 \quad L = 30$$

$$C = 20 \quad f = 28$$

$$\text{Median} = L_1 + \frac{\left(\frac{N}{2} - C\right)}{f} \times i$$

$$= 20 + \frac{(30-20)}{28} \times 10$$

$$= 23.57$$

Question16

$\sum_{i=1}^n (x - x_i)$ is equal to

- (a) $x \sum_{i=1}^n \bar{x}$ (b) $n (x \sum_{i=1}^n \bar{x})$
(c) $\bar{x} - n\bar{x}$ (d) zero

Answer: d

Explanation:

$$(d) \sum_{i=1}^n (x - x_i)$$

Since the sum of deviations about their AM is always zero.

Question17

SD from numbers 1, 4, 5, 7, 8 is 2.45. If 10 is added to each them SD will be:

- (a) 12.45 (b) 24.5
(c) 12 (d) will not change

Answer: d

Explanation:

(d) We know a change in origin of SD causes no change in SD
So, New SD = Original SD when 10 will be added
So, SD will not change .

DEC 2020

Question1

Given the weights for the numbers 1, 2, 3,.....n are respectively $1^2, 2^2, 3^2, \dots, n^2$.

Then weighted HM is _____

- | | |
|----------------------|----------------------|
| (a) $\frac{2n+1}{4}$ | (b) $\frac{2n+1}{6}$ |
| (c) $\frac{2n+1}{3}$ | (d) $\frac{2n+1}{2}$ |

Answer: c

Explanation:

Since the harmonic mean is the reciprocal of the average of reciprocals, the formula to define the harmonic mean “HM” is given as follows:

If $x_1, x_2, x_3, \dots, x_n$ are the individual items up to n terms, then,

Harmonic Mean, $HM = n / [(1/x_1) + (1/x_2) + (1/x_3) + \dots + (1/x_n)]$. Hence = $\frac{2n+1}{3}$

Question2

Which measure is suitable for open - end classification?

- | | |
|------------|----------|
| (a) Median | (b) Mean |
| (c) Mode | (d) GM |

Answer: a

Explanation:

For open end classification median is the best measure of central tendency. Median is the most suitable central tendency measure when there are some extreme scores in data distribution and also when there is a skewed data set.

Question3

50th percentile is equal to _____

- | | |
|------------|----------|
| (a) Median | (b) Mode |
| (c) Mean | (d) None |

Answer: a

Explanation:

The 50th percentile is generally the median (if you're using the third definition—see below). The 75th percentile is also called the third quartile. The difference between the third and first quartiles is the interquartile range.

Question4

For a distribution Mean, Median and Mode are 23, 24 and 25.5 respectively, then it is most likely ___ skewed distribution

- (a) Positively (b) Symmetrical
(c) Asymptotically (d) Negatively

Answer: d

Explanation:

For Negatively skewed means is likely to be less than mode and median

Question5

If any two numbers are in AP, then $GM^2 =$ ____

- (a) AM x HM (b) AM + HM
(c) M x Z (d) AM x M

Answer: a

Explanation:

The relationship between AM, GM and HM is given by:

$$AM \times HM = GM^2$$

Question6

Two values yielded an arithmetic mean of 24 and a harmonic mean of 6. The geometric mean of these values is ____

- (a) 8 (b) 12
(c) 14 (d) 16

Answer: b

Explanation:

$$GM = \sqrt{AM \times HM}$$

$$GM = \sqrt{24 \times 6}$$

$$GM = \sqrt{144}$$

$$GM = 12$$

Question 7

The HM of A and B is $1/3$ and HM of C and D is $1/5$. Then HM of A, B, C and D is

- (a) $\frac{8}{15}$ (b) $\frac{1}{4}$
(c) $\frac{15}{8}$ (d) $\frac{4}{15}$

Answer: d

Explanation:

AB- $1/3$ & CD- $1/5$

HM of ABCD = $n/2$

$$\frac{\frac{1}{3} + \frac{1}{5}}{2} \left(\frac{n}{2}\right) = \frac{8}{30} = \frac{4}{15}$$

Question 8

Which one of these is least affected by extreme values?

- (a) Mean (b) Median
(c) Mode (d) None

Answer: b

Explanation:

Median is the middle most value of a given series that represents the whole class of the series. So since it is a positional average, it is calculated by observation of a series and not through the extreme values of the series which. Therefore, median is not affected by the extreme values of a series.

Question9

Ten matches' data is given. Then which of the following cannot be found?

- (a) Least Score (b) Highest Score
(c) Best Score (d) Median Score

Answer: c

Explanation:

From Best Score method we can do this

Question10

If the AM and HM of two numbers are 6 and 9 respectively, then GM is_____

- (a) 7.35 (b) 8.5
(c) 6.75 (d) None

Answer: a

Explanation:

We know the relation between Arithmetic Mean, Harmonic Mean, and Geometric Mean of Two Numbers:

$$A.M. \times H.M. = (G.M.)^2$$

$$\Rightarrow G.M. = 7.35$$

Question11

Which of the following measure of dispersion is based on absolute deviations?

- (a) Range (b) SD
(c) Mean Deviation (d) Quartile Deviation

Answer: c

Explanation:

The Mean Deviation gives more information than range or the Quartile Deviation as it is based on all the observed values. The Mean Deviation does not give undue weight to occasional large deviations, so it should likely to be used in situation where such deviations are likely to occur.

IAN 2021

Question1

From the records on sizes of shoes sold in a shop, one can compute the following to determine the most preferred shoe size.

- | | |
|----------|------------|
| (a) Mean | (b) Median |
| (c) Mode | (d) Range |

Answer: c

Explanation:

The number which appears most often in a set of numbers. Example: in {6, 3, 9, 6, 6, 5, 9, 3} the Mode is 6

Question2

Which of the following measure does not possess mathematical properties?

- | | |
|---------------------|--------------------|
| (a) Arithmetic mean | (b) Geometric mean |
| (c) Harmonic mean | (d) Median |

Answer: d

Explanation:

Median Properties - The median value is fixed by its position and is not reflected by the individual value. The distance between the median and the rest of the values is less than the distance from any other point. Every array has a single median. Median cannot be manipulated algebraically. **Hence, Median does not possess mathematical properties**

Question 3

If $y = 3 + (4.5)x$ and the mode for x-value is 20, then the mode for y-value is

- | | |
|-----------|--------|
| (a) 3.225 | (b) 12 |
| (c) 24.5 | (d) 93 |

Answer: d

Explanation:

$$y = 3 + (4.5)x$$

x is 20

$$y = 3 + 4.5 \times 20$$

$$y = 93$$

Because Mode is affected by change of origin & scale both

Question 4

If there are two groups with n_1 and n_2 observations and H_1 and H_2 are respective harmonic means, then the harmonic mean of combined observations is

- | | |
|---|---|
| (a) $\frac{n_1 H_1 + n_2 H_2}{n_1 + n_2}$ | (b) $\frac{n_1 H_1 + n_2 H_2}{H_1 + H_2}$ |
|---|---|

$$(c) \frac{n_1+n_2}{n_1H_1+n_2H_2}$$

$$(d) \frac{(n_1+n_2)H_1H_2}{n_1H_2+n_2H_1}$$

Answer: d

Explanation:

$$\frac{(n_1 + n_2)H_1H_2}{n_1H_2 + n_2H_1}$$

Question 5

The best statistical measure used for comparing two series is

- (a) Mean absolute deviation (b) Range
(c) Certificate of variation (d) Standard deviation

Answer: c

Explanation:

The coefficient of standard deviation is calculated by dividing the standard deviation of the series by its mean and then multiplying it by 100. It is regarded as the best measure of dispersion to compare two different series because it is expressed in percentage.

Question 6

The relationship between P-series and Q-series is given by $2P - 3Q - 10$. If the range of P – series is 18. What would be the range of Q?

- (a) 10 (b) 15
(c) 9 (d) 12

Answer: d

Question 7

It is given that the mean (\bar{X}) is 10 and standard deviation (s.d.) is 3.2. If the observations are increased by 4, then the new mean and standard deviations are:

- (a) $\bar{x} = 10$, s.d. = 7.2 (b) $\bar{x} = 10$, s.d. = 3.2
(c) $\bar{x} = 14$, s.d. = 3.2 (d) $\bar{x} = 14$, s.d. = 7.2

Answer: d

Explanation:

$$\bar{x} + 4 = \text{New Mean}$$

$$\bar{x} = 10 + 4 = 14$$

Mean is affect by change in origin

$$\text{S.D.} = \sigma + 4$$

$$\text{S.D.} = 3.2 + 4 = 3.2$$

as SD is not affected by change of origin

Question 8

Which one of the following is a relative measure of dispersion?

- (a) Range (b) Mean deviation

(c) Standard deviation

(d) Coefficient of quartile deviation

Answer: d**Explanation:**

The relative Measures of dispersion are: Coefficient of Variation, Coefficient of Quartile Deviation, Coefficient of Mean Deviation

Question 9

Find the coefficient of mean deviation about mean for the data: 5, 7, 8, 10, 11, 13, 19

(a) 17.28

(b) 28.57

(c) 32.12

(d) 18.56

Answer: c**Explanation:**

$$\text{Mean } (\bar{x}) = \frac{5 + 7 + 8 + 10 + 11 + 13 + 19}{7} = \frac{54}{7} = 7.714$$

	$ x_i - \bar{x} $
5	2.271
7	0.714
8	0.29
10	2.29
11	3.29
13	5.29
$\sum x_i - \bar{x} $	14.15

NOTE:The correct Ans is: 32.12**JULY 2021****Question 1**

Expenditures of a company (in Million Rupees) per item in various Years

Year	Item of Expenditures				
	Salary	Fuel and Transport	Bonus	Interest on Loans	Taxes
1998	288	98	3.00	23.4	83
1999	342	112	2.52	32.5	108
2000	324	101	3.84	41.6	74
2001	336	133	3.68	36.4	88
2002	420	142	3.96	49.4	98

What is average amount of interest per year which the company had to pay

For more Info Visit - www.KITest.in

during this period?

- (a) 33.66 (b) 36.66
(c) 31.66 (d) 39.66

Answer: Options (b)

Question 2

There are n numbers. When 50 is subtracted from each of these numbers the sum of the numbers so obtained is -10. When 46 is subtracted from each of the original n numbers, then the sum of numbers, so obtained is 70. What is the mean of the original n numbers?

- (a) 56.8 (b) 25.7
(c) 49.5 (d) 53.8

Answer: Options (c)

Question 3

The mean of ' n ' observation is ' X '. If k is added to each observation, then the new mean is __

- (a) X (b) XK
(c) $X - K$ (d) $X + K$

Answer: Options (d)

Explanation:

Let us take n observation X_1, \dots, X_n

If \bar{X} be the mean of the n observation, then we have

$$\bar{X} = \frac{1}{n} \sum_{i=1}^n X_i$$

$$\rightarrow \sum_{i=1}^n X_i = n\bar{X}$$

Add a constant k to each of the observations. Then the observations becomes

$X_1 + k, \dots, X_n + k$

If \bar{Y} be the mean of the new observations. Then the observations becomes

$$\bar{Y} = \frac{1}{n} \sum_{i=1}^n (X_i + k)$$

$$= \frac{1}{n} \sum_{i=1}^n X_i + \frac{1}{n} \sum_{i=1}^n k$$

$$= \bar{X} + \frac{1}{n} \cdot nk$$

$$= \bar{X} + k$$

Question 4

If $y = 3 + 1.9x$, and mode of x is 15, then the mode of y is:

- (a) 15.9 (b) 27.8
(c) 35.7 (d) 31.5

Answer: Options (d)

Question 5

The mean deviation of the numbers 3, 10, 6, 11, 14, 17, 9, 8, 12 about the mean is (correct to one decimal place)

- (a) 8.7 (b) 4.2
(c) 3.1 (d) 9.8

Answer: Options (c)

Question 6

The standard deviation of 1 to 9 natural number is___

- (a) 6.65 (b) 2.58
(c) 6.75 (d) 5.62

Answer: Options (b)

Question 7

The probable value of mean deviation when $Q_3 = 40$ and $Q_1 = 15$ is___

- (a) 15 (b) 18.75
(c) 17.50 (d) 0

Answer: Options (a)

Explanation:

$$Q_3 = 40 \quad Q_1 = 15$$

$$QD = \frac{Q_3 - Q_1}{2}$$

$$QD = \frac{40 - 15}{2}$$

$$= \frac{25}{2}$$

$$= 12.5$$

$$\text{WKT, } 6QD = 5MD = 4SD$$

$$MD = \frac{6 * 12.5}{5}$$

$$MD = 15$$

Question 8

If the numbers are 5, 1, 8, 7, 2, then the coefficient of variation is

- (a) 56.13% (b) 59.13%
(c) 48.13% (d) 44.13%

Answer: Options (b)

Question 9

If every observation is increased by 7 then

- (a) Standard Deviation increases by 7 (b) Mean deviation increases by 7
(c) Not affected at all (d) Quartile Deviation increases by 7

Answer: Options (c)

Question 10

If a school has 14 teachers, their heights (in cm) are:

172, 173, 164, 178, 168, 169, 173, 172, 173, 164, 178, 168, 169, 173, then average deviation of this data is

- (a) 2.43 approx. (b) 3.93 approx.
(c) 3.43 approx. (d) 2.92 approx.

Answer: Options (c)

Question 11

If the relationship between x and y is given by $2x + 3y = 10$ and the range of y is 10, then what is the range of x?

- (a) 10 (b) 18
(c) 8 (d) 15

Answer: Options (d)

DEC 2021

Question 1

If there are 3 observations 15, 20, 25 then the sum of deviation of the observations from their AM is

- (a) 0 (b) 5
(c) -5 (d) 10

Answer: a

Explanation:

Sum of deviations from their Arithmetic Mean is always zero.

Question 2

If the AM and GM for 10 observations are both 15, then the value of HM is

- (a) less than 15 (b) more than 15
(c) 15 (d) cannot be determined

Answer:

Explanation:

If both AM and GM are 15, it means that all the observations are constant, i.e., 15. Therefore, HM will also be 15.

Question 3

If average mark for a group of 30 girls is 80, a group of boys is 70 and combined average is 76, then how many are in the boy's group?

- (a) 21 (b) 20
(c) 22 (d) 19

Answer: b

Explanation:

We have $n_1 = 30$; $\bar{X}_1 = 80$; $n_2 = ?$; $\bar{X}_2 = 70$; $\bar{X} = 76$

We know that $\bar{X} = \frac{n_1\bar{X}_1 + n_2\bar{X}_2}{n_1 + n_2}$

Therefore, $76 = \frac{(30 \times 80) + (n_2 \times 70)}{30 + n_2}$

Now, try the options.

Option (a) - 21

$$RHS = \frac{(30 \times 80) + (21 \times 70)}{30 + 21} = 75.88 \neq 76$$

Option (b) - 20

$$RHS = \frac{(30 \times 80) + (20 \times 70)}{30 + 20} = 76 = LHS$$

Question 4

If two variables a and b are related by $C = ab$ then G.M. of c is equal to

- (a) G.M. of a + G.M. of b
 (b) G.M. of a x G.M. of b
 (c) G.M. of a - G.M. of b
 (d) G.M. of a / G.M. of b

Answer: b

Explanation:

If two variables a and b are related by $c = ab$ then GM of c = GM of a × GM of b

Question 5

For a moderately skewed distribution the median is twice the mean, then the mode is _____ times the median.

- (a) 3
 (b) 2
 (c) 2/3
 (d) 3/2

Answer: b

Explanation:

We know that for a moderately skewed distribution,

$$\text{Mode} = 3 \text{ Median} - 2 \text{ Mean} \dots \text{Eq. (1)}$$

Given:

$$\text{Median} = 2 \text{ Mean}$$

$$\text{Therefore, Mean} = \text{Median} / 2$$

Putting

$$\text{the value of Mean} = \text{Median} / 2$$

in Eq. (1), we get:

$$\text{Mode} = 3 \text{ Median} - 2 (\text{Median} / 2)$$

$$\text{Mode} = 3 \text{ Median} - \text{Median} = 2 \text{ Median}$$

Therefore, Mode is two times of Median.

Question 6

The median value of the set of observations 48, 36, 72, 87, 19, 66, 56, 91 is

- (a) 53
 (b) 87

(c) 61

(d) 19

Answer: c**Explanation:**

First, arrange the terms in ascending order:

19, 36, 48, 56, 66, 72, 87, 91

Since the number of terms is even, i.e., 8, the median will be obtained by the average of the two middle terms, i.e., 56, and 66.

Therefore,

$$\text{Median} = \frac{56 + 66}{2} = 61$$

Question 7**The marks secured by 5 students in a subject are 82, 73, 69, 84, 66. What is the coefficient of Range**

(a) 0.12

(b) 12

(c) 120

(d) 0.012

Answer: b**Explanation:**

$$\text{Coefficient of Range} = \frac{\text{Largest Observation} - \text{Small}}{\text{Largest Observation} + \text{Small}}$$

$$\text{Coefficient of Range} = \frac{84 - 66}{84 + 66} \times 100 = 12$$

Question 8**For a data having odd number of values, the difference between the first and the middle value is equal to the difference between the last and the middle value; similarly the difference between the second and middle values is equal to that of second last and middle value so on. Therefore, the middle value is equal to**

(a) Half of the range

(b) Half of standard deviation

(c) Mode

(d) Mean

Answer: d**Explanation:**

Here No. of data's = odd (let 3)

i.e. a, b, c

Difference b/w the 1st and the middle value

Diff. b/w the last and the middle value

$$b - a = c - b$$

$$2b = a + c$$

$$b = \frac{a + c}{2}$$

The middle value is known as mean and similarly other case is also satisfied.

Question 9**One hundred participants expressed their opinion on recommending a new**

product to their friends using the attributes: most unlikely, not sure, likely, most likely. The appropriate measure of central tendency that can be used here is

- (a) Mean (b) Mode
(c) Geometric mean (d) Harmonic mean

Answer: b

Explanation:

One hundred participants expressed their opinion on recommending a new product to their friends using the Attributes; most unlikely, not sure, likely, most likely. The appropriate measure of central tendency that can be used here is **Mode**.

Question 10

A long a road there are 5 buildings of apartments, marked as 1, 2, 3, 4, 5. Number of people residing in each building is available. A bus stop is to be setup near one of the buildings so that the total distance walked by the residents to the bus stop from their buildings must be kept minimum. One must consider involving _____ to find the position of the bus stop.

- (a) Mean (b) Mode
(c) Median (d) Weighted mean

Answer:

Explanation:

'Median' The total distance walked by the residents to the bus stop from their building must DO kept minimum.

Question 11

Given that Mean = 70.20 and Mode = 70.50, the Median is expected to be.

- (a) 70.15 (b) 70.20
(c) 70.30 (d) 70.35

Answer:

Explanation:

Since Mean and Mode are different, this data is clearly not symmetric. For moderately skewed data, we know that Mode = 3Median - 2 Mean.

Therefore, Median = $\frac{\text{Mode} + 2 \text{ Mean}}{3}$

$$\text{Median} = \frac{70.50 + (2 \times 70.20)}{3} = 70.30$$

JUNE 2022

Question 1

Which is not a measure of central tendency

- (a) Mean (b) Median
(c) Quartile deviation (d) Mode

Answer: c**Explanation:**

Quartile deviation is not a measure of central tendency.

Question 2**Mean Deviation of data 3, 10, 10, 4, 7, 18, 5 from mode is**

- (a) 4.39 (b) 4.14
(c) 4.70 (d) 5.24

Answer: b**Explanation:**

Mean deviation from mode of following data 3, 10, 10, 4, 7, 18, 5

Here mode (M_o) = 10

Table =

x	Mode (M_o)	$ d = x - M_o $
3	10	7
10	10	0
10	10	0
4	10	6
7	10	3
18	10	8
5	10	5
N = 7		$\Sigma d = 29$

$$\text{M.D.} = \frac{\Sigma|d|}{N} = \frac{29}{7} = 4.14$$

Question 3**A M and Coefficient of variation of x is 10 and 40. What is the variance $30 - 2x$**

- (a) 64 (b) 56
(c) 49 (d) 81

Answer: a**Explanation:**

A.M of x = 10

C.v. of x = 40%

$$CV = \frac{S.D.}{A.M} \times 100$$

$$40 = \frac{10}{S.D.} \times 100$$

$$S.D. = \frac{40 \times 10}{100}$$

$$S.D = 4$$

i.e. S.D of x=4

Here Let $y = 30 - 2x$

$$2x + y - 30 = 0$$

$$B = \frac{\text{Coeff of } x}{\text{Coeff of } y} = \frac{-2}{1} = -2$$

S.D of y = |b| of S.D of x

$$= |-2| \times 4 = 2 \times 4 = 8$$

$$= \text{Variance of } y = (8)^2 = 64$$

Question 4

Which of the following is based on absolute deviation?

- | | |
|------------------------|------------------------|
| (a) Standard deviation | (b) Mean deviation |
| (c) Range | (d) Quartile deviation |

Answer: b

Explanation:

M. D is known as absolute deviation

Question 5

When each value does not have equal importance then

- | | |
|---------|----------------------|
| (a) A M | (b) G M |
| (c) H M | (d) Weighted Average |

Answer: d

Explanation:

When each value does not have equal importance then we used weighted Average.

Question 6

Following are the wages of 8 workers 82, 96, 52, 75, 70, 65, 50, 70. Find range and coefficient of range?

- | | |
|---------------|---------------|
| (a) 46, 32.70 | (b) 43, 31.50 |
| (c) 46, 31.50 | (d) 43, 32.70 |

Answer: c

Explanation:

Here Smallest No (S) = 50

Largest No (L) = 96

Range = L - S

$$= 96 - 50$$

$$= 46$$

$$\text{Coeff. of Range} = \frac{L-S}{L+S} \times 100$$

$$\frac{96-50}{96+50} \times 100$$

$$= \frac{46}{146} \times 100$$

$$= 31.50$$

Question 7

The mean of 20 observation is 38. If two observation are taken as 84 and 36 instead of 48 and 63 find new means.

- (a) 38.45 (b) 41.15
(c) 37.55 (d) 40.05

Answer: c

Explanation:

$$\bar{X} = 38$$

No of observation (N) = 20

Right Values (R.V) = 48 + 63 = 111

Wrong Values (W.V) = 84 + 36 = 120

New (correct) mean = original mean + $\frac{R.V - W.V}{N}$

$$= 38 + \frac{(111 - 120)}{20}$$

$$= 38 + \frac{(-9)}{20}$$

$$= 38 + 0.45$$

$$= 37.55$$

Question 8

The 3rd decile for the numbers 15, 10, 20, 25, 18, 11, 9, 12 is

- (a) 13 (b) 10.70
(c) 11.00 (d) 11.50

Answer: b

Explanation:

Write the terms in Ascending order 9, 10, 11, 12, 15, 18, 20, 25

Here N = 8

$$D_3 = \left[\frac{3(N+1)}{10} \right]^{th}$$

$$\left[\frac{3(8+1)}{10} \right]^{th}$$

$$\left[\frac{27}{10} \right]^{th}$$

2.70th term

$$= 2^{th} \text{ term} + 0.70 (3^{th} \text{ term} - 2^{th} \text{ term})$$

$$= 10 + 0.70 (11 - 10)$$

$$= 10 + 0.70 \times 1$$

$$= 10 + 0.70$$

$$= 10.70$$

Question 9

Find the standard deviation and coefficient of variation for 1, 9, 8, 5, 7

- (a) 2.828, 49.32 (b) 2.828, 47.13
 (c) 2.828, 48.13 (d) 2.828, 50.13

Answer: c

Explanation:

Given data

1, 9, 8, 5, 7

$$\text{Mean } (\bar{x}) = \frac{\sum d^2}{N} = \sqrt{\frac{40}{5}} = \sqrt{8}$$

$$= 2\sqrt{2}$$

$$= .828$$

$$\text{C.V} = \frac{\text{S.D}}{\text{AM}} \times 100$$

$$\frac{2.828}{6} \times 100 = 47.13\%$$

DEC 2022

Question 1

If Mean (X) is = 10 and mode (Z) is = 7, then find out the value of median (M)

- a) 9 b) 17
 c) 3 d) 4.33

Answer: Options (a)

Explanation:

Applying the relation between mean, median and mode formula,

Mode = 3 Median - 2 Mean

$$\text{Therefore, Median} = \frac{\text{Mode} + 2\text{Mean}}{3}$$

$$= \frac{7 + 2 \times 10}{3}$$

$$= 27$$

Median = 9

Question 2

If the coefficient of variation and standard deviation are 30 and 12 respectively, then the arithmetic mean of the distribution is

- a) 40 b) 36
 c) 25 d) 19

Answer: Options (a)

Explanation:

C.V. - 30, S.D - 12

c) 63.80

d) 156.71

Answer: Options (b)**Explanation:**

$$Q_1 = 56.5$$

$$Q_3 = 77.5$$

$$\text{Coef. of QD} = \frac{Q_3 - Q_1}{Q_3 + Q_1} \times 100$$

$$\frac{77.5 - 56.5}{77.5 + 56.5} \times 100$$

$$\frac{21}{134} \times 100 = 15.67$$

Question 7**The median of the observation 42, 72, 35, 92, 67, 85, 72, 81, 51, 56 is**

a) 69.5

b) 72

c) 64

d) 61.5

Answer: Options (a)**Explanation:**

42, 72, 35, 92, 67, 85, 72, 81, 51, 56

No' of observations (n) = 10

first of all we arrange the observations in an ascending order

35, 42, 51, 56, 67, 72, 72, 81, 85, 92

Here observe that No' of observations (n) is even so

Median is average of $\frac{n}{2}$ th term and $(\frac{n}{2} + 1)$ th term

$$\text{Median} = \frac{\frac{n}{2} \text{th term} + (\frac{n}{2} + 1) \text{th term}}{2}$$

$$\frac{\frac{10}{2} \text{th term} + (\frac{10}{2} + 1) \text{th term}}{2}$$

$$\frac{5 \text{th term} + 6 \text{th term}}{2}$$

$$= \frac{67 + 72}{2}$$

$$= \frac{139}{2}$$

$$= 69.5$$

Question 8**If the sum of square of the values equals to 3390. Number of observation are 30 and Standard deviation is 7, what is the mean value of the above observations?**

a) 14

b) 11

c) 8

d) 5

Answer: Options (c)

Answer: Options (b)**Explanation:**

If the arithmetic mean is 5, therefore the sum of the two numbers is 10.

Let the two numbers be x and $10 - x$

The geometric mean is 4

$$\text{So, } \sqrt{x(10 - x)} = 4$$

On squaring both sides, we get

$$x(10 - x) = 16$$

$$\Rightarrow 10x - x^2 = 16$$

$$\Rightarrow x^2 - 10x + 16 = 0$$

$$\Rightarrow x^2 - 8x - 2x + 16 = 0$$

$$\Rightarrow x(x - 8) - 2(x - 8) = 0$$

$$\Rightarrow (x - 2)(x - 8) = 0$$

$$\Rightarrow x = 2 \text{ or } x = 8$$

So, the required numbers are 2 and 8

Question 12

If Arithmetic mean between two numbers is 5 and Geometric mean is 4 then what is the value of Harmonic mean?

a) 3.2

b) 3.4

c) 3.5

d) 3.6

Answer: Options (a)**Explanation:**

We know If a and b are two positive numbers then,

Therefore, we can conclude the relationship between A.M., G.M. & H.M. is:

$$\boxed{\text{G.M.} = \sqrt{\text{A.M.} \times \text{H.M.}}}$$

Now, substituting A.M. = 5 & G.M. = 4, we get

$$4 = \sqrt{5 \times \text{H.M.}}$$

Squaring both sides

$$\Rightarrow (4)^2 = (\sqrt{5 \times \text{H.M.}})^2$$

$$\Rightarrow 16 = 5 \times \text{H.M.}$$

$$\Rightarrow \text{H.M.} = \frac{16}{5}$$

$$\Rightarrow \text{H.M.} = 3.2$$

Thus, the Harmonic mean between the two numbers is 3.2.

Question 13

If the variance of given data is 12, and their mean value is 40, what is coefficient variation (CV)?

a) 5.66%

b) 6.66%

c) 7.50%

d) 8.65%

Answer: Options (d)**Explanation:**

$$\text{Coef. of } \sigma^2 = \frac{\sigma}{x} \times 100$$

$$= \frac{\sqrt{12}}{40} \times 100$$

$$= 8.65\%$$

CHAPTER - 15 PROBABILITY

PROBABILITY	The terms 'Probably' 'in all likelihood', 'chance', 'and odds in favor', 'odds against' are too familiar nowadays and they have their origin in a branch of Mathematics.
RANDOM EXPERIMENT	An experiment is defined to be random if the results of the experiment depend on chance only.
EXPERIMENT	An experiment may be described as a performance that produces certain results.
EVENTS	The results or outcomes of a random experiment are known as events. Sometimes events may be combination of outcomes. The events are of two types: <p style="text-align: center;">(i) Simple or Elementary, (ii) Composite or Compound</p>
MUTUALLY EXCLUSIVE EVENTS OR INCOMPATIBLE EVENTS	A set of events A_1, A_2, A_3, \dots is known to be mutually exclusive if not more than one of them can occur simultaneously
EXHAUSTIVE EVENTS	The events A_1, A_2, A_3 , are known to form an exhaustive set if one of these events must necessarily occur.
EQUALLY LIKELY EVENTS OR MUTUALLY SYMMETRIC EVENTS OR EQUI-PROBABLE EVENTS	The events of a random experiment are known to be equally likely when all necessary evidence are taken into account, no event is expected to occur more frequently as compared to the other events of the set of events.
CLASSICAL DEFINITION OF PROBABILITY OR A PRIOR DEFINITION	The probability of occurrence of the event A is defined as the ratio of the number of events Favorable to A to the total number of events. Denoting this by P (A), we have. $P(A) = \frac{\text{No. of equally likely events Favorable to A}}{\text{Total no. of equally likely events}}$

REMEMBERANCE POINT & FORMULA

- (a) The probability of an event lies between 0 and 1, both inclusive.

When $P(A) = 0$, A is known to be an impossible event and when $P(A) = 1$, A is known to be a sure event.

- (b) Non-occurrence of event A is denoted by A' or A^C . The event A along with its complimentary A' forms a set of mutually exclusive and exhaustive events i.e.,

$$P(A) + P(A') = 1$$

$$P(A') = 1 - P(A)$$

- (c) The ratio of no. of favorable events to the no. of unfavorable events is known as odds in favor of the event A and its inverse ratio is known as odds against the event A i.e.,

$$\text{odds in favor of A} = m_A : (m - m_A)$$

$$\text{and odds against A} = (m - m_A) : m_A$$

- (d) For any two mutually exclusive events A and B, the probability that either A or B occurs is given by the sum of individual probabilities of A and B i.e.,

$$P(A + B)$$

$$P(A + B) = P(A) + P(B)$$

- (e) For any $K(+ 2)$ mutually exclusive events $A_1, A_2, A_3, \dots, A_K$ the probability that at least one of them occurs is given by the sum of the individual probabilities of the events i.e.,

$$P(A_1 + A_2 + \dots + A_K) = P(A_1) + P(A_2) + \dots + P(A_K)$$

- (f) For any two events A and B, the probability that either A or B occurs is given by the sum of individual probabilities of A and B less the probability of simultaneous occurrence of the events A and B i.e.,

$$P(A + B) = P(A) + P(B) - P(A \cap B)$$

- (g) For any three events A, B and C, the probability that at least one of the events occurs is given by

$$P(A + B + C) = P(A) + P(B) + P(C) - P(A + B) - P(A + C) - P(B + C) + P(A + B + C)$$

- (h) For any two events A and B, the probability that A and B occur simultaneously is given by the product of the unconditional probability of A and the conditional probability of B given that A has already occurred i.e.,

$$P(A * B) = P(A) \times P(B/A) \quad \text{Provided}$$

$$P(A) > 0$$

- (i) Compound Probability or Joint Probability

$$P(B/A) = \frac{P(A + B) - P(A)}{P(A)}$$

GRAPHICAL FORMULA OF PROBABILITY

$$P(A) = \frac{\text{number of favourable events}}{\text{number of total events}}$$

$$P(A) = \frac{n(A)}{n}$$

$$P(B) = \frac{n(B)}{n}$$

$$P(A \cap B) = P(A) P(B)$$

for Mutually Exclusive Events

$$P(A \cup B) = P(A) + P(B)$$

for non-Mutual Events

$$P(A \cup B) = P(A) + P(B) - P(A \cap B)$$

for Conditional probability

$$P(A | B) = \frac{P(A \cap B)}{P(B)}$$



Question 1

What is the chance of picking a spade or an ace not of spade from a pack of 52 cards?

- (a) $\frac{4}{13}$ (b) $\frac{4}{14}$
 (c) $\frac{15}{13}$ (d) $\frac{6}{13}$

Answer: a

Explanation:

A pack of 52 cards contain 13 spades, 13 Hearts, 13 Clubs and 13 Diamonds. Each of these groups of 13 cards has an ace. Hence the total number of elementary events is 52 out of which 13 + 3 or 16 are favorable to the event. A representing picking a space or an ace not of spade. This we have

$$P(A) = \frac{16}{52} = \frac{4}{13}$$

Question 2

A committee of 7 members is to be formed form a group comprising 8 gentlemen and 5 ladies. What is the probability that the committee would comprise: 2 ladies.

- (a) $\frac{140}{429}$ (b) $\frac{14}{429}$
 (c) $\frac{10}{49}$ (d) None

Answer: a

Explanation:

Since there is altogether 8 + 5 or 13 persons, committee 7 members can be formed in ${}^{13}C_7$ Or $\frac{13!}{7!6!}$ or $\frac{13 \times 12 \times 11 \times 10 \times 9 \times 8!}{7! \times 6 \times 5 \times 4 \times 3 \times 2 \times 1}$ or $11 \times 12 \times 13$ ways.

When the committee is formed taking 2 ladies out of 5 ladies, the remaining (7-2) or 5 committee members are to be selected from 8 gentlemen. Now 2 out of 5 ladies can be selected in 5C_2 ways and 5 out of 8 gentlemen can be selected in 8C_5 ways. Thus if A denotes the event of having the committee with 2 ladies, then A can occur in ${}^5C_2 \times {}^8C_5$ OR 10×56 Ways thus,

$$P(A) = \frac{10 \times 56}{11 \times 12 \times 13} = \frac{140}{429}$$

Question 3

What if in above questions 2. 2 ladies be replacing by at least 2 ladies?

- (a) $\frac{92}{429}$ (b) $\frac{32}{29}$
 (c) $\frac{392}{429}$ (d) None

Answer: c

Explanation:

Since the minimum number of ladies is 2, we can have the following combinations:

Population:	8G	+	5L
Sample	2L	+	5G
or	3L	+	4G
or	4L	+	3G
or	5L	+	2G

Thus if B denotes the event of having at least two ladies in the committee, then B can occur in ${}^5C_2 \times {}^8C_5 + {}^5C_3 \times {}^8C_4 + {}^5C_4 \times {}^8C_3 + {}^5C_5 + {}^8C_2$ i.e. 1568 ways.

$$\text{Hence } P(A) = \frac{1568}{11 \times 12 \times 13} = \frac{392}{429}$$

Question 4

A bag contains 2 red, 3 green and 2 blue balls. Two balls are drawn at random.

What is the probability that none of the balls drawn is blue?

- (a) $\frac{10}{21}$ (b) $\frac{11}{21}$
 (c) $\frac{2}{7}$ (d) $\frac{5}{7}$

Answer: a

Explanation:

Total number of balls = (2 + 3 + 2) = 7.

Let S be the sample space.

Then, n(S) = Number of ways of drawing 2 balls out of 7

$$\begin{aligned} &= {}^7C_2 \\ &= \frac{(7 \times 6)}{(2 \times 1)} \\ &= 21. \end{aligned}$$

LET e = Event of drawing 2 balls, none of which is blue.

\therefore n (E) = Number of ways of drawing 2 balls out of (2 + 3) balls.

$$\begin{aligned} &= {}^5C_2 \\ &= \frac{(5 \times 4)}{(2 \times 1)} \\ &= 10. \end{aligned}$$

$$\therefore P(E) = \frac{n(E)}{n(S)} = \frac{10}{21}$$

Question 5

In a box, there are 8 red, 7 blue and 6 green balls. One ball is picked up randomly. What is the probability that it is neither red nor green?

- (a) $\frac{1}{3}$ (b) $\frac{3}{4}$
 (c) $\frac{7}{19}$ (d) $\frac{8}{21}$

Answer: a

Explanation:

Total number of balls = $(8 + 7 + 6) = 21$.
 event that the ball drawn is neither red or nor green

 event that the ball drawn is blue.

$$\therefore n(E) = 7.$$

$$\therefore P(E) = \frac{n(E)}{n(S)} = \frac{7}{21} = \frac{1}{3}$$

Question 6

What is the probability of getting a sum 9 from two throws of a dice?

- (a) $\frac{1}{6}$ (b) $\frac{1}{8}$
 (c) $\frac{1}{9}$ (d) $\frac{1}{12}$

Answer: c

Explanation:

In two throws a dice $n(S) = (6 \times 6) = 36$.

Let E = event of getting a sum = $\{(3, 6), (4, 5), (5, 4), (6, 3)\}$

$$\therefore P(E) = \frac{n(E)}{n(S)} = \frac{4}{36} = \frac{1}{9}$$

Question 7

Three unbiased coins are tossed. What is the probability of getting at most two heads?

- (a) $\frac{3}{4}$ (b) $\frac{1}{4}$
 (c) $\frac{3}{8}$ (d) $\frac{7}{8}$

Answer: d

Explanation:

Here $S = \{TTT, TTH, THT, HTT, THH, HTH, HHT, HHH\}$

Let E = event of getting at most heads.

Then $E = \{TTT, TTH, THT, HTT, THH, HTH, HHT\}$.

$$\therefore P(E) = \frac{n(E)}{n(S)} = \frac{7}{8}$$

Question 8

Two dice are thrown simultaneously. What is the probability of getting two numbers whose product is even?

- (a) $\frac{1}{2}$ (b) $\frac{3}{4}$
 (c) $\frac{3}{8}$ (d) $\frac{5}{16}$

Answer: b

Explanation:

In a simultaneously throw of two dice. We have $n(S) = (6 \times 6) = 36$.

Then $E = \{(1, 2), (1, 4), (1, 6), (2, 1), (2, 2), (2, 3), (2, 4), (2, 5), (2, 6), (3, 2), (3, 4), (3, 6), (4, 1), (4, 2), (4, 3), (4, 4), (4, 5), (4, 6), (5, 2), (5, 4), (5, 6), (6, 1), (6, 2), (6, 3), (6, 4), (6, 5), (6, 6)\}$

$$\therefore n(E) = 27.$$

$$\therefore p(E) = \frac{n(E)}{n(S)} = \frac{27}{36} = \frac{3}{4}$$

Question 9

In a class, there are 15 boys and 10 girls. Three students are selected at random. The probability that 1 girl and 2 boys are selected is:

- (a) $\frac{21}{46}$ (b) $\frac{25}{117}$
 (c) $\frac{1}{50}$ (d) $\frac{3}{25}$

Answer: a

Explanation:

Let S be the sample space and E be the event selecting 1 girl and 2 boys.

Then, $n(S) =$ Number Ways of selecting 3 student out of 25

$$\begin{aligned} &= {}^{25}C_3 \\ &= \frac{(25 \times 24 \times 23)}{(3 \times 2 \times 1)} \\ &= 2300 \end{aligned}$$

$$\begin{aligned} n_E &= ({}^{10}C_1 \times {}^{15}C_2) \\ &= \left[10 \times \frac{(15 \times 14)}{2 \times 1} \right] \\ &= 1050. \end{aligned}$$

$$\therefore P(E) = \frac{n(E)}{n(S)} = \frac{1050}{2300} = \frac{21}{46}$$

Question 10

In a lottery, there are 10 prizes and 25 blanks. A lottery is drawn at random. What is the probability of getting a prize?

- (a) $\frac{1}{10}$ (b) $\frac{2}{5}$
 (c) $\frac{2}{7}$ (d) $\frac{5}{7}$

Answer: c

Explanation:

$$P(\text{getting a prize}) = \frac{10}{(10+25)} = \frac{10}{35} = \frac{2}{7}$$

Question 11

From a pack of 52 cards, two cards are drawn together at random. What is the probability of both the cards being kings?

- (a) $\frac{1}{15}$ (b) $\frac{25}{57}$
 (c) $\frac{1}{221}$ (d) $\frac{35}{256}$

Answer: c

Explanation:

Let S be the sample space.

$$\text{Then, } n(S) = {}^{52}C_2 = \frac{(52 \times 51)}{(2 \times 1)} = 1326.$$

Let E = event of getting 2 kings out of 4.

$$\therefore n(E) = {}^4C_2 = \frac{(4 \times 3)}{(2 \times 1)} = 6.$$

$$\therefore P(E) = \frac{n(E)}{n(S)} = \frac{6}{1326} = \frac{1}{221}$$

Question 12

Two dice are tossed. The probability that the total score is a prime number is:

- (a) $\frac{1}{6}$ (b) $\frac{5}{12}$
 (c) $\frac{1}{2}$ (d) $\frac{7}{9}$

Answer: b

Explanation:

Clearly, $n(S) = (6 \times 6) = 36$.

Let E = Event that the sum is a prime number.

Then $E = \{(1, 1), (1, 2), (1, 4), (1, 6), (2, 1), (2, 3), (2, 5), (3, 2), (3, 4), (4, 1), (4, 3), (5, 2), (5, 6), (6, 1), (6, 5)\}$

$\therefore n(E) = 15$.

$$\therefore P(E) = \frac{n(E)}{n(S)} = \frac{15}{36} = \frac{5}{12}$$

Question 13

A card is drawn from a pack of 52 cards. The probability of getting a queen of club or a king of heart is:

- (a) $\frac{1}{13}$ (b) $\frac{2}{13}$
 (c) $\frac{1}{26}$ (d) $\frac{1}{52}$

Answer: c

Explanation:

Here, $n(S) = 52$.

Let E = event of getting a queen of club or a king of heart.

Then, $n(E) = 2$.

$$\therefore P(E) = \frac{n(E)}{n(S)} = \frac{2}{52} = \frac{1}{26}$$

Question 14

Two cards are drawn together from a pack of 52 cards. The probability that one is a spade and one is a heart, is:

- (a) $\frac{3}{20}$ (b) $\frac{29}{34}$
 (c) $\frac{47}{100}$ (d) $\frac{13}{102}$

Answer: d

Explanation:

Let S be the sample space.

Then, $n(S) = {}^{52}C_2 = \frac{(52 \times 51)}{(2 \times 1)} = 1326$.

Let E = event of getting 1 spade and 1 heart.

$$\begin{aligned} \therefore N(E) &= \text{number of ways of choosing 1 spade out of 13 and 1 heart out of 13} \\ &= ({}^{13}C_1 \times {}^{13}C_1) \\ &= (13 \times 13) \\ &= 169. \end{aligned}$$

$$\therefore P(E) = \frac{n(E)}{n(S)} = \frac{169}{1326} = \frac{13}{102}$$

Question 15

One card is drawn at random from a pack of 52 cards. What is the probability that the card drawn is a face card (jack, Queen, and King only)?

- (a) $\frac{1}{13}$ (b) $\frac{3}{13}$
 (c) $\frac{1}{4}$ (d) $\frac{9}{52}$

Answer: b

Explanation:

Clearly, there are 52 cards out of which there are 12 face cards.

$$\therefore P(\text{getting a face card}) = \frac{12}{52} = \frac{3}{13}$$

Question 16

A bag contains 6 black and 8 white balls; one ball is drawn at random. What is the probability that the ball drawn is white?

- (a) $\frac{3}{4}$ (b) $\frac{4}{7}$
 (c) $\frac{1}{8}$ (d) $\frac{3}{7}$

Answer: b

Explanation:

Let number of balls = $(6 + 8) = 14$.

Number of white balls = 8.

$$P(\text{drawing a white ball}) = \frac{8}{14} = \frac{4}{7}$$

Question 17

A bag contains 6 white and 4 black balls, 2 balls are drawn at random. Find the probability that they are of same colour.

- (a) $\frac{1}{2}$ (b) $\frac{7}{15}$
 (c) $\frac{8}{15}$ (d) $\frac{1}{9}$

Answer: b

Explanation:

Let S be the Sample space

$$\begin{aligned} \text{Then } n(S) &= \text{no of ways drawing 2 balls out of } (6+4) \\ &= {}^{10}C_2 = 45 \end{aligned}$$

Let E = event of getting both balls of same colour

$$\begin{aligned} \text{Then, } n(E) &= \text{no of ways (2 balls out of six) or (2 balls out of 4)} \\ &= {}^6C_2 + {}^4C_2 \\ &= 15 + 6 = 21 \end{aligned}$$

$$\text{Therefore, } P(E) = \frac{n(E)}{n(S)} = \frac{21}{45} = \frac{7}{15}$$

Question 18

A problem is given to three students whose chance of solving is are $\frac{1}{2}$, $\frac{1}{3}$ and $\frac{1}{4}$ respectively what is the probability that the problem will be solved?

- (a) $\frac{1}{4}$ (b) $\frac{1}{2}$
 (c) $\frac{3}{4}$ (d) $\frac{7}{12}$

Answer: c

Explanation:

Let A, B, C be the respective events solving the problem and \bar{A} , \bar{B} , \bar{C} be the respective events of not solving the problem. Then A, B, C are independent event

$\therefore \bar{A}$, \bar{B} , \bar{C} are independent events

Now $P(A) = \frac{1}{2}$, $P(B) = \frac{1}{3}$ and $P(C) = \frac{1}{4}$

$P(\bar{A}) = \frac{1}{2}$, $P(\bar{B}) = \frac{2}{3}$, $P(\bar{C}) = \frac{3}{4}$

$\therefore P(\text{none solves the problem}) = P(\text{not A and (not B) and (not C)})$
 $= P(\bar{A} \cap \bar{B} \cap \bar{C})$
 $= P(\bar{A}) P(\bar{B}) P(\bar{C})$ [$\because \bar{A}, \bar{B}, \bar{C}$ are Independent]

$$= \frac{1}{2} \times \frac{2}{3} \times \frac{3}{4}$$

$$= \frac{1}{4}$$

Hence, $P(\text{the problem will be solved}) = 1 - P(\text{none solves the problem})$
 $= 1 - \frac{1}{4} = \frac{3}{4}$

Question 19

Two cards are drawn at random from a pack of 52 cards what is the probability that either both are black or both are queen?

(a) $\frac{52}{221}$

(b) $\frac{55}{190}$

(c) $\frac{55}{221}$

(d) $\frac{19}{221}$

Answer: c**Explanation:**

We have $n(S) = {}^{52}C_2 = \frac{52 \times 51}{2 \times 1} = 1326$.

Let A = event of getting both black cards

B = event of getting both queens

$A \cap B$ = event of getting queen of black cards

$$n(A) = \frac{52 \times 51}{2 \times 1} = {}^{26}C_2 = 325.$$

$$n(B) = \frac{26 \times 25}{2 \times 1} = \frac{4 \times 3}{2 \times 1} = 6 \text{ and}$$

$$n(A \cap B) = {}^4C_2 = 1$$

$$P(A) = \frac{n(A)}{n(S)} = \frac{325}{1326};$$

$$P(B) = \frac{n(B)}{n(S)} = \frac{6}{1326} \text{ and}$$

$$P(A \cap B) = \frac{n(A \cap B)}{n(S)} = \frac{1}{1326}$$

$$P(A \cup B) = P(A) + P(B) - P(A \cap B) = \frac{(325+6-1)}{1326} = \frac{330}{1326} = \frac{55}{221}$$

Question 20

Tickets numbered 1 to 20 are mixed up and then a ticket is drawn at random. What is the probability that the ticket drawn has a number which is a multiple of 3 or 5?

(a) $\frac{1}{2}$

(b) $\frac{3}{5}$

(c) $\frac{9}{20}$

(d) $\frac{8}{15}$

Answer: c**Explanation:**

Here, $S = \{1, 2, 3, 4, \dots, 19, 20\}$

Let $E =$ event of getting multiple of 3 or 5 $= \{3, 6, 9, 12, 15, 18, 5, 10, 20\}$.

$$P(E) = \frac{n(E)}{n(S)} = \frac{9}{20}$$

Question 21

Two dice are tossed. The probability that the total score is a prime number is:

- (a) $\frac{5}{12}$ (b) $\frac{1}{6}$
 (c) $\frac{1}{2}$ (d) $\frac{7}{9}$

Answer: a

Explanation:

Clearly, $n(S) = (6 \times 6) = 36$.

Let $E =$ Event that the sum is a prime number.

Then $E = \{(1, 1), (1, 2), (1, 4), (1, 6), (2, 1), (2, 3), (2, 5), (3, 2), (3, 4), (4, 1), (4, 3), (5, 2), (5, 6), (6, 1), (6, 5)\}$

$n(E) = 15$.

$$P(E) = \frac{n(E)}{n(S)} = \frac{15}{36} = \frac{5}{12}$$

Question 22

A man and his wife appear in an interview for two vacancies in the same post. The probability of husband's selection is $\left(\frac{1}{7}\right)$ and the probability of wife's selection is $\left(\frac{1}{5}\right)$. What is the probability that only one of them is selected?

- (a) $\frac{2}{7}$ (b) $\frac{1}{7}$
 (c) $\frac{3}{4}$ (d) $\frac{4}{5}$

Answer: a

Explanation:

Let $A =$ Event that the husband is selected

And $B =$ Event that the wife is selected

Then, $P(A) = \frac{1}{7}$ and $P(B) = \frac{1}{5}$

$$\therefore P(\bar{A}) = \left(1 - \frac{1}{7}\right) = \frac{6}{7} \text{ and } P(\bar{B}) = \left(1 - \frac{1}{5}\right) = \frac{4}{5}$$

\therefore Required probability $= P[(A \text{ and not } B) \text{ or } (B \text{ and not } A)]$

$$= P[(A \text{ and } \bar{B}) \text{ or } (B \text{ and } \bar{A})]$$

$$= P[(A \text{ and } \bar{B}) + P(B \text{ and } \bar{A})]$$

$$= P(A) - P(\bar{B}) + P(B) - P(\bar{A}) = \left(\frac{1}{7} \times \frac{4}{5}\right) + \left(\frac{1}{5} \times \frac{6}{7}\right) = \frac{10}{35} = \frac{2}{7}$$

Question 23

A bag contains 4 white, 5 red and 6 blue balls, three balls are drawn at random from the bag. The probability that all of them are red is:

- (a) $\frac{2}{91}$ (b) $\frac{1}{22}$
 (c) $\frac{3}{22}$ (d) $\frac{2}{77}$

Answer: a

Explanation:

Let S be the sample space.

Then, $n(S) =$ number of ways of drawing 3 balls out of 15

$$= {}^{15}C_3 = \frac{15 \times 14 \times 13}{3 \times 2 \times 1} = 455.$$

Let E = event of getting all the 3 red balls.

$$n(E) = {}^5C_3 = \frac{5 \times 4}{2 \times 1} = 10.$$

$$\Rightarrow P(E) = \frac{n(E)}{n(S)} = \frac{10}{455} = \frac{2}{91}$$

Question 24

In a lottery, there are 10 prizes and 25 blanks; a lottery is drawn at random. What is the probability of getting a prize?

(a) $\frac{2}{7}$

(b) $\frac{1}{5}$

(c) $\frac{1}{5}$

(d) $\frac{1}{2}$

Answer: a

Explanation:

Total number of outcomes possible, $n(S) = 10 + 25 = 35$

$$P(E) = n(E)/n(S) = 10/35 = 2/7$$

Question 25

In a class, there are 15 boys and 10 girls. Three students are selected at random. The probability that 1 girl and 2 boys are selected is:

(a) $\frac{21}{46}$

(b) $\frac{1}{5}$

(c) $\frac{3}{25}$

(d) $\frac{1}{50}$

Answer: a

Explanation:

Let, S – sample space E – event of selecting 1 girl and 2 boys.

Then, $n(S) =$ Number ways of selecting 3 students out of 25

$$= {}^{25}C_3 = 2300.$$

$$n(E) = {}^{10}C_1 \times {}^{15}C_2 = 1050.$$

$$\therefore P(E) = \frac{n(E)}{n(S)} = \frac{1050}{2300} = \frac{21}{46}$$

Question 26

What is the probability of getting 53 Mondays in a leap year?

(a) $\frac{1}{7}$

(b) $\frac{3}{7}$

(c) $\frac{2}{7}$

(d) None of these

Answer: c

Explanation:

1 year = 365 days. A leap year has 366 days

A year has 52 weeks. Hence there will be 52 Sundays for sure.

$$52 \text{ weeks} = 52 \times 7 = 364 \text{ days}$$

$$366 - 364 = 2 \text{ days}$$

In a leap year there will be 52 Sundays and 2 days will be left.

These 2 days can be:

1. Sunday, Monday
2. Monday, Tuesday
3. Tuesday, Wednesday
4. Wednesday, Thursday

5. Thursday, Friday

6. Friday, Saturday

7. Saturday, Sunday

Of these total 7 outcomes, the favorable outcomes are 2.

Hence the probability of getting 53 days = $\frac{2}{7}$

Question 27

Two dice are thrown together. What is the probability that the sum of the number on the two faces is divided by 4 or 6?

(a) $\frac{7}{18}$

(b) $\frac{14}{35}$

(c) $\frac{8}{18}$

(d) $\frac{7}{35}$

Answer: a

Explanation:

Clearly, $n(S) = 6 \times 6 = 36$

Let E be the event that the sum of the b=numbers on the two faces is divided by 4 or 6, Then, $E = \{(1, 3), (1, 5), (2, 2), (2, 4), (2, 6), (3, 1), (3, 3), (3, 5), (4, 2), (4, 4), (5, 1), (5, 3), (6, 2), (6, 6)\}$

$n(E) = 14.$

Hence, $P(E) = \frac{n(E)}{n(S)} = \frac{14}{36} = \frac{7}{18}$

Question 28

One card is drawn at random from pack of 52 cards. What is the probability that the card drawn is face card (Jack, Queen and king only)?

(a) $\frac{3}{13}$

(b) $\frac{1}{13}$

(c) $\frac{3}{52}$

(d) $\frac{9}{52}$

Answer: a

Explanation:

Clearly, there are 52 cards, out of which there are 12 face cards.

$P(\text{getting a face card}) = \frac{12}{52} = \frac{3}{13}.$

Question 29

Two cards are drawn together from a pack of 52 cards. The probability that one is a spade and one is a heart, is:

(a) $\frac{3}{20}$

(b) $\frac{29}{34}$

(c) $\frac{47}{100}$

(d) $\frac{13}{102}$

Answer: d

Explanation:

Let S be the sample space.

Then, $n(S) = {}^{52}C_2 = \frac{(52 \times 51)}{(2 \times 1)} = 1326$

Let E = event of getting 1 spade and 1 heart.

$n(E) =$ number of ways of choosing 1 spade out of 13 and 1 heart out of 13

$= {}^{13}C_1 \times {}^{13}C_1 = 169.$

$P(E) = \frac{n(E)}{n(S)} = \frac{169}{1326} = \frac{13}{102}$

Question 30

A bag contains 6 black and 8 white balls; one ball is drawn at random. What is the probability that the ball drawn is white?

- (a) $\frac{3}{7}$ (b) $\frac{4}{7}$
 (c) $\frac{1}{8}$ (d) $\frac{3}{4}$

Answer: b

Explanation:

Let number of balls = $(6+8) = 14$.

Number of white balls = 8

$P(\text{drawing a white ball}) = \frac{8}{14} = \frac{4}{7}$.

Question 31

In a class 30% of the students offered English, 20% offered Hindi and 10% offered both. If a student is selected at random. What is the probability that he, has offered English or Hindi?

- (a) $\frac{1}{2}$ (b) $\frac{3}{4}$
 (c) $\frac{4}{5}$ (d) $\frac{2}{5}$

Answer: d

Explanation:

$P(E) = \frac{30}{100} = \frac{3}{10}$, $P(H) = \frac{20}{100} = \frac{1}{5}$ and $P(E \cap H) = \frac{10}{100} = \frac{1}{10}$

$P(E \text{ OR } H) = P(E \cup H)$
 $= P(E) + P(H) - P(E \cap H)$
 $= \left(\frac{3}{10} + \frac{1}{5} - \frac{1}{10}\right) = \frac{4}{10} = \frac{2}{5}$

Question 32

If two letters are taken at random from the word HOME. What is the probability that none of the letters would be vowels?

- (a) $\frac{1}{6}$ (b) $\frac{1}{2}$
 (c) $\frac{1}{3}$ (d) $\frac{1}{4}$

Answer: a

Explanation:

$P(\text{first letter is not vowel}) = 2/4$

$P(\text{second letter is not vowel}) = 1/3$

So, probability that none of the letters would be vowels is $= 2/4 * 1/3 = 1/6$

Question 33

Two cards are drawn at random from a pack of 52 cards. The probability that both are the cards of space is

- (a) $\frac{1}{26}$ (b) $\frac{1}{4}$
 (c) $\frac{1}{17}$ (d) None of these

Answer: c

Explanation:

Required probability $= \frac{{}^{13}C_2}{{}^{52}C_2} = \frac{13 \cdot 12}{52 \cdot 51} = \frac{1}{17}$

Question 33

5 boys and 5 girls are sitting in a row randomly. The probability that boys and girls sit alternatively is:

- (a) $\frac{5}{126}$ (b) $\frac{1}{126}$
 (c) $\frac{4}{126}$ (d) $\frac{6}{125}$

Answer: b

Explanation:

Let n = total no. of ways = $10!$

m = favorable no. of ways = $2 \times 5! \cdot 5!$

Since the boys and girls can sit alternately in $5! \cdot 5!$ Ways if began with a boy and similarly they can sit alternately in $5! \cdot 5!$ Ways if we begin with a girl

Hence, required probability = $\frac{m}{n} = \frac{2 \times 5! \cdot 5!}{10!} = \frac{2 \times 5!}{10 \times 9 \times 8 \times 7 \times 6} = \frac{1}{126}$

Question 34

Fifteen persons among whom are A and B, sit down at random at a round table. The probability that there are 4 persons between A and B, is

- (a) $\frac{1}{3}$ (b) $\frac{2}{3}$
 (c) $\frac{2}{7}$ (d) $\frac{1}{7}$

Answer: d

Explanation:

Let A occupy any seat at the round table. Then there are 14 seats available for B. If there are to be four persons between A and B

Then B has only two ways to sit, as show in the fig. hence required probability $\frac{2}{14} = \frac{1}{7}$

Question 35

From eighty cards numbered 1 to 80, two cards are selected randomly. The probability that both the cards have the numbers divisible by 4 is given by

- (a) $\frac{21}{316}$ (b) $\frac{19}{316}$
 (c) $\frac{1}{4}$ (d) None

Answer: b

Explanation:

Total numbers of ways = $80C_2$ and favorable ways = $20C_2$

Required probability $P = \frac{80C_2}{20C_2} = \frac{19}{316}$

Question 36

A bag contains 8 red and 7 black balls. Two balls are drawn at random. The probability that both the balls are of the same colour is

- (a) $\frac{14}{15}$ (b) $\frac{11}{15}$
 (c) $\frac{7}{15}$ (d) $\frac{4}{15}$

Answer: c

Explanation:

Required probability = either the balls are red or the balls are black

$$\frac{{}^8C_2}{{}^{15}C_2} + \frac{{}^7C_2}{{}^{15}C_2} = \frac{28+21}{105}$$

$$\frac{49}{105} = \frac{7}{15}$$

Question 37

5 persons A, B, C, D and E are in queue of a shop. The probability that A and E always together, is:

- (a) $\frac{1}{4}$ (b) $\frac{2}{3}$
 (c) $\frac{2}{5}$ (d) $\frac{3}{5}$

Answer: c

Explanation:

Total number of ways = 5!

Favorable number of ways 2.4!

Hence required probability

$$\frac{2.4!}{5!} = \frac{2}{5}$$

Question 38

A drawer contains 5 brown socks and 4 blue socks well mixed. A man reaches the drawer pulls out 2 socks at random. What is the probability that they match?

- (a) $\frac{4}{9}$ (b) $\frac{5}{8}$
 (c) $\frac{5}{9}$ (d) $\frac{7}{12}$

Answer: a

Explanation:

Out of 9 socks, 2 can be drawn in 9C_2 ways.

Two socks drawn from the drawer will match if either both are brown or both are blue.

$${}^5C_2 + {}^4C_2$$

$$\text{Hence the required probability} = \frac{{}^5C_2 + {}^4C_2}{{}^9C_2} = \frac{4}{9}$$

Question 39

Ten students are seated at random in a row. The probability that two particular students are not seated side by side is

- (a) $\frac{4}{5}$ (b) $\frac{3}{5}$
 (c) $\frac{2}{5}$ (d) $\frac{1}{5}$

Answer: a

Explanation:

Total ways = 10!

Two boys can sit by side in $2 \times 9!$ Ways.

$$\text{So probability} = \frac{2 \times 9!}{10!} = \frac{1}{5}$$

Thus the probability that they are not seated together is $1 - \frac{1}{5} = \frac{4}{5}$

Question 40

A fair coin is tossed 100 times. The probability of getting tails and odd number of times is

(a) $\frac{1}{2}$
 (c) $\frac{3}{8}$

(b) $\frac{1}{8}$
 (d) None

Answer: a

Explanation:

The total numbers of cases are 2^{100}

The number of favorable ways $100c_1 + 100c_3 + \dots + 100c_{99} = 2^{100} - 1 = 2^{99}$

$$= \frac{2^{99}}{2^{100}} = \frac{1}{2}$$

Question 41

Three cards are drawn at random from a pack of 52 cards. What is the chance of drawing three aces?

(a) $\frac{3}{5525}$
 (c) $\frac{1}{5525}$

(b) $\frac{2}{5525}$
 (d) None

Answer: c

Explanation:

Required probability is $\frac{{}^4C_3}{{}^{52}C_3} = \frac{1}{5525}$

Question 42

A bag contains 4 white, 5 red and 6 green balls. Three balls are picked up randomly. The probability that a white, a red and a green ball is drawn is

(a) $\frac{15}{91}$
 (c) $\frac{20}{91}$

(b) $\frac{30}{31}$
 (d) $\frac{24}{91}$

Answer: d

Explanation:

Required probability = $\frac{4 \cdot 5 \cdot 6}{{}^{15}C_3} = \frac{24}{91}$

Question 43

Two numbers are selected randomly from the set $S = \{1, 2, 3, 4, 5, 6\}$ without replacement one by one. The probability that minimum of the two numbers is less than 4 is

(a) $\frac{1}{15}$
 (c) $\frac{1}{5}$

(b) $\frac{14}{15}$
 (d) $\frac{4}{5}$

Answer: d

Explanation:

Total ways = $2! {}^6C_2 = 30$

Favorable cases = $30 - 6 = 24$

Required probability = $\frac{24}{30} = \frac{4}{5}$

Question 44

A bag contains 5 black balls, 4 white balls and 3 red balls. If a ball is selected random wise, the probability that it is a black or red ball is

(a) $\frac{1}{3}$

(b) $\frac{1}{4}$

(c) $\frac{5}{12}$

(d) $\frac{2}{3}$

Answer: d**Explanation:**

$$P(\text{Black or Red}) = \frac{{}^5C_1 + {}^3C_1}{{}^{12}C_1} = \frac{2}{3}$$

Question 45

In a lottery there were 90 tickets numbered 1 to 90. Five tickets were drawn at random. The probability that two of the tickets drawn numbers 15 and 89 is

(a) $\frac{2}{801}$

(b) $\frac{2}{623}$

(c) $\frac{1}{267}$

(d) $\frac{1}{623}$

Answer: a**Explanation:**

$$\text{Required probability} = \frac{{}^{88}C_3}{{}^{90}C_5} = \frac{2}{801}$$

Question 46

A bag contains 3 red, 4 white, and 5 black balls. Three balls are drawn at random. The probability of being their different colors is

(a) $\frac{3}{11}$

(b) $\frac{2}{11}$

(c) $\frac{8}{11}$

(d) None

Answer: a**Explanation:**

Total number of balls in a bag are $3 + 4 + 5 = 12$

Three balls drawn at random is ${}^{12}C_3$

When the all three ball are drawn different ${}^3C_1 \times {}^4C_1 \times {}^5C_1$

Now probability that three ball drawn from bag random and different colors

$$\begin{aligned} \text{is } \frac{{}^3C_1 \times {}^4C_1 \times {}^5C_1}{{}^{12}C_3} &= \frac{\left(\frac{3!}{1! \times 2!} \times \frac{4!}{1! \times 3!} \times \frac{5!}{1! \times 4!}\right)}{\frac{12!}{9! \times 3!}} \\ &= \frac{3 \times 4 \times 5 \times 6}{12 \times 11 \times 10} \\ &= \frac{3}{11} \end{aligned}$$

Therefore, the probability that the three balls drawn from bag of being their different colors is $\frac{3}{11}$

Thus correct answer is option (A)

Question 47

Dialing a telephone number an old man forgets the last two digits remembering only that these are different dialed at random. The probability that the number is dialed correctly, is

(a) $\frac{1}{45}$

(b) $\frac{1}{90}$

(c) $\frac{1}{100}$

(d) $\frac{1}{80}$

Answer: b**Explanation:**

There are 10 digits 0, 1, 2, 3, 4, 5, 6, 7, 8, 9.

The last two digits can be dialed in $10P_2 = 90$ ways.

Out of which only one way is favorable. Thus the required probability = $\frac{1}{90}$

Question 48

Two friends A and B have equal number of daughters. There are three cinema tickets which are to be distributed among the daughters of A and B. The probability that all the tickets go to daughters of A is $\frac{1}{20}$. The numbers of daughters each of them have is

- (a) 4 (b) 5
(c) 6 (d) 3

Answer: d

Explanation:

Let A and B each have x daughters

∴ Probability that all tickets go to all daughter of A = $\frac{{}^xC_3}{{}^{2x}C_3}$

$$= \frac{x(x-1)(x-2)}{2x(2x-1)(2x-2)} = \frac{1}{20}$$

$$\rightarrow \frac{x-2}{4(2x-1)} = \frac{1}{20} \rightarrow 20x - 40 = 8x - 4$$

$$\rightarrow 12x = 36 \rightarrow x = 3$$

Number of daughters each have = 3

Question 49

From a class of 12 girls and 18 boys, two students are chosen randomly. What is the probability that both of them are girls?

- (a) $\frac{22}{145}$ (b) $\frac{13}{15}$
(c) $\frac{1}{8}$ (d) none

Answer: a

Explanation:

$$\text{Required probability} = \frac{{}^{12}C_2}{{}^{30}C_2} = \frac{12 \times 11}{30 \times 29} = \frac{22}{145}$$

Question 50

Twenty tickets are marked the numbers 1, 2, 20. If their tickets be drawn at random, then what is the probability that those marked 7 and 11 are among them.

- (a) $\frac{3}{190}$ (b) $\frac{1}{19}$
(c) $\frac{1}{190}$ (d) None

Answer: a

Explanation:

7 and 11 have always 10 be in that group of three, therefore 3rd ticket may be chosen in 18 ways.

$$\text{Hence required probability is } \frac{18}{{}^{20}C_3} = \frac{18 \cdot 3 \cdot 2}{20 \cdot 19 \cdot 18} = \frac{3}{190}$$

Question 51

The letter of the word 'ASSASSIN' are written down at random in arrow. The probability that no two S occur together is

- (a) $\frac{1}{35}$ (b) $\frac{1}{14}$
 (c) $\frac{1}{15}$ (d) None

Answer: b

Explanation:

Total ways of arrangements = $\frac{8!}{2!4!} w \cdot x \cdot y \cdot z$

Now S can have places at dot's and in places of w, x, y, z

We have to put 2A's, one I and one N.

Therefore favorable ways = $5 \left(\frac{4!}{2!} \right)$

Hence required probability = $\frac{5 \cdot 4! 2! 4!}{21 \cdot 8!}$
 $= \frac{1}{14}$

Question 52

A and B are two independent events such that $P(A) = \frac{1}{2}$ and $P(B) = \frac{1}{3}$. Then P (neither A nor B) is equal to

- (a) $\frac{2}{3}$ (b) $\frac{1}{6}$
 (c) $\frac{5}{6}$ (d) $\frac{1}{3}$

Answer: d

Explanation:

$P(\text{neither A nor B}) = P(\bar{A} \cap \bar{B}) = P(\bar{A}) \cdot P(\bar{B})$

$= P(\bar{A}) = 1 - P(A) = 1 - \frac{1}{2} = \frac{1}{2}$

$= P(\bar{B}) = 1 - P(B) = 1 - \frac{1}{3} = \frac{2}{3}$

$\therefore P(\bar{A}) \cdot P(\bar{B}) = \frac{1}{2} \times \frac{2}{3} = \frac{1}{3}$

Question 53

In a throw of a dice the probability of getting one in even number of throw is

- (a) $\frac{5}{36}$ (b) $\frac{5}{11}$
 (c) $\frac{6}{11}$ (d) $\frac{1}{6}$

Answer: b

Explanation:

Probability of getting 1 on 2nd throw,

$P(2) \left(\frac{5}{6} \right) \left(\frac{1}{6} \right)$

Probability of getting 1 on 4th throw,

$P(4) \left(\frac{5}{6} \right)^3 \left(\frac{1}{6} \right)$

Probability of getting 1 on 6th throw,

$P(6) \left(\frac{5}{6} \right)^5 \left(\frac{1}{6} \right)$

Therefore total probability

$P = P(2) + P(4) + P(6) + \dots$

$P = \left(\frac{5}{6} \right) \left(\frac{1}{6} \right) + \left(\frac{5}{6} \right)^3 \left(\frac{1}{6} \right) + \left(\frac{5}{6} \right)^5 \left(\frac{1}{6} \right) + \dots$

$$P = \frac{1}{6} \left[\left(\frac{5}{6}\right) + \left(\frac{5}{6}\right)^3 + \left(\frac{5}{6}\right)^5 + \dots \right]$$

By sum of an infinite geometric series,

$$P = \frac{1}{6} \left[\frac{\frac{1}{6}}{1 - \left(\frac{5}{6}\right)^2} \right]$$

$$P = \frac{5}{11}$$

PAST EXAMINATION QUESTIONS:

MAY 2018

Question 1

Two broad divisions of probability are:

- | | |
|--|--|
| (a) Subjective probability and objective probability | (b) Deductive probability and mathematical probability |
| (c) Statistical probability and mathematical probability | (d) None |

Answer: a

Explanation:

Two broad and divisions of probability are

- A. Subjective probability
- B. Objective probability

Question 2

The term "chance" and probability is synonyms:

- | | |
|----------|-----------|
| (a) True | (b) False |
| (c) Both | (d) None |

Answer: a

Explanation:

The terms "chance" and probability are synonyms is True.

Question 3

The theorem of compound probability states that for any two A and B

- | | |
|---|---|
| (a) $P(A \cap B) = P(A) \times P\left(\frac{B}{A}\right)$ | (b) $P(A \cup B) = P(A) \times P\left(\frac{B}{A}\right)$ |
| (c) $P(A \cap B) = P(A) \times P(B)$ | (d) $P(A \cup B) = P(A) + P(B) - P(A \cap B)$ |

Answer: a

Explanation:

The theorem of compound probability states that for only events A and B given by

$$P(A \cap B) = P(A) \times P\left(\frac{B}{A}\right)$$

Question 4

Variance of a random variable x is given by

- (a) $E(X-\mu)^2$ (b) $E[X-E(X)]^2$
 (c) $E(X^2-\mu)$ (d) (a) or (b)

Answer: d

Explanation:

Variance of a random variable x is given by $V(x) = E(x-\mu)^2$

Or

$$V(x) = [E(X-E(x))]^2$$

Question 5

What is the probability of having at least one 'six' year's throws of a project die?

- (a) $\frac{5}{6}$ (b) $\left(\frac{5}{6}\right)^3$
 (c) $1-\left(\frac{1}{6}\right)^3$ (d) $1-\left(\frac{5}{6}\right)^3$

Answer: d

Explanation:

For a die probability of getting six

$$P(A) = \frac{1}{6} \rightarrow p$$

$$P(\bar{A}) = 1 - \frac{1}{6} = \frac{5}{6} \rightarrow q$$

Here $n = 3$

$$P(\text{getting at least '1' six}) = P(X \geq 1)$$

$$= 1 - P(X < 1)$$

$$= 1 - P(X = 0)$$

$$= 1 - {}_3C_0 \cdot \left[\frac{1}{6}\right]^0 \cdot \left(\frac{5}{6}\right)^{3-0}$$

$$= 1 - 1 \times 1 \times \left[\frac{5}{6}\right]^3$$

$$= 1 - \left[\frac{5}{6}\right]^3$$

Question 6

Sum of all probabilities mutually exclusive and exhaustive events is equal to

- (a) 0 (b) $\frac{1}{2}$
 (c) $\frac{1}{4}$ (d) 1

Answer: d

Explanation:

Sum of all probabilities mutually exclusive and exhaustive events is equal to 1

NOV 2018

Question 1

If $P(A) = \frac{1}{2}$, $P(B) = \frac{1}{3}$, and $P(A \cap B) = \frac{1}{4}$, then $P(A \cup B)$ is equal to

- | | |
|---------------------|---------------------|
| (a) $\frac{11}{12}$ | (b) $\frac{10}{12}$ |
| (c) $\frac{7}{12}$ | (d) $\frac{1}{6}$ |

Answer: c

Explanation:

$$P(A) = \frac{1}{2}, P(B) = \frac{1}{3}, \text{ and } P(A \cap B) = \frac{1}{4}$$

We know that

$$P(A \cup B) = P(A) + P(B) - P(A \cap B)$$

$$\frac{1}{2} + \frac{1}{3} - \frac{1}{4}$$

$$\frac{6+4-3}{12} = \frac{7}{12}$$

Question 2

The probability that a leap year has 53 Wednesday is

- | | |
|-------------------|-------------------|
| (a) $\frac{2}{7}$ | (b) $\frac{3}{5}$ |
| (c) $\frac{2}{3}$ | (d) $\frac{1}{7}$ |

Answer: a

Explanation:

In a leap year, there are 366 days.

366 days = 52 weeks and 2 days.

2 odd days may be:

(a) Sunday and Monday

(b) Monday and Tuesday

(c) Tuesday and Wednesday $n(S) = 7$

(d) Wednesday and Thursday

(e) Thursday and Friday $n(A) = 2$

(f) Friday and Saturday $P(A) = \frac{2}{7}$

(g) Saturday and Sunday

No. of sample space

Event (A) = 'getting Wednesday'

Question 3

A coin is tossed six times, then the probability of obtaining heads and tails alternatively is

$$(a) \frac{1}{2}$$

$$(c) \frac{1}{32}$$

$$(b) \frac{1}{64}$$

$$(d) \frac{1}{16}$$

Answer: c

Explanation:

If one coin is tossed '6' times

$$P(H) = \frac{1}{2}, P(T) = \frac{1}{2}$$

$$P(\text{Alternate getting 'H' \& "T"}) = P(HT HT HT) + P(TH TH TH)$$

$$\frac{1}{2} \times \frac{1}{2} \times \frac{1}{2} \times \frac{1}{2} \times \frac{1}{2} \times \frac{1}{2} + \frac{1}{2} \times \frac{1}{2} \times \frac{1}{2} \times \frac{1}{2} \times \frac{1}{2} \times \frac{1}{2}$$

$$\frac{1}{64} + \frac{1}{64} = \frac{2}{64} = \frac{1}{32}$$

Question 4

Ram is known to hit a target in 2 out of 3 shots whereas Shyam is known to hit the same target in 5 out of 11 shots. What is the probability that the target would be hit if they both try?

$$(a) \frac{9}{11}$$

$$(c) \frac{10}{11}$$

$$(b) \frac{3}{11}$$

$$(d) \frac{6}{11}$$

Answer: a

Explanation:

$$\text{Probability of hitting the target by Ram } P(A) = \frac{2}{3}$$

$$\text{Probability of hitting the target by Shyam } P(B) = \frac{5}{11}$$

$$P(\bar{A}) = 1 - \frac{2}{3} = \frac{1}{3}$$

$$P(\bar{B}) = 1 - \frac{5}{11} = \frac{6}{11}$$

$$P(\text{Target WOULD be HIT}) = 1 - P(\bar{A} \cap \bar{B})$$

$$1 - P(\bar{A}) \cdot P(\bar{B})$$

$$1 - \frac{1}{3} \times \frac{6}{11}$$

$$= 1 - \frac{2}{11} = \frac{9}{11}$$

Question 5

Two different dice are thrown simultaneously, then the probability, that the sum of two numbers appearing on the top of dice is 9 is

$$(a) \frac{8}{9}$$

$$(c) \frac{7}{9}$$

$$(b) \frac{1}{9}$$

$$(d) \text{None}$$

Answer: b

Explanation:

If two dice are rolled then

Sample space $n(s) = 6^2 = 36$

Event (A) = Getting the sum is '9'
 $= \{(6, 3) (3, 6)(4, 5) (5, 4)\}$

$n(A) = 4$

$$P(A) = \frac{n(A)}{n(S)} = \frac{4}{36} = \frac{1}{9}$$

Question 6

If $P(A \cup B) = 0.8$ and $P(A \cap B) = 0.3$, then $P(\bar{A}) + P(\bar{B})$ is equal to

- (a) 0.3 (b) 0.5
 (c) 0.7 (d) 0.9

Answer: d

Explanation:

Given

$P(A \cup B) = 0.8$ and $P(A \cap B) = 0.3$

We know that

$$P(A \cup B) = P(A) + P(B) - P(A \cap B)$$

$$0.8 = [1 - P(\bar{A})] + [1 - P(\bar{B})] - 0.3$$

$$P(\bar{A}) + P(\bar{B}) = 2 - 0.3 - 0.8$$

$$P(\bar{A}) + P(\bar{B}) = 0.9$$

MAY 2019

Question 1

If a coin is tossed 5 times, then the probability of getting Tail and Head occurs alternatively is:

- (a) $\frac{1}{18}$ (b) $\frac{1}{16}$
 (c) $\frac{1}{32}$ (d) $\frac{1}{64}$

Answer: c

Explanation:

$$\frac{1}{2} \times \frac{1}{2} \times \frac{1}{2} \times \frac{1}{2} \times \frac{1}{2} = \frac{1}{32}$$

Question 2

According to Bayes's theorem,

$$P(E_k|A) = \frac{P(E_k)P\left(\frac{A}{E_k}\right)}{\sum_{i=1}^n P(E_i)P\left(\frac{A}{E_i}\right)} \text{ here}$$

- (a) E_1, E_2, \dots are mutually exclusive (b) $P\left(\frac{E}{A}\right), P\left(\frac{E}{A_2}\right), \dots$ are equal to 1

(c) $P\left(\frac{A_1}{E}\right), P\left(\frac{A_2}{E}\right)$ Are equal to 1 (d) A & E's are disjoint sets

Answer: a

Explanation:

Mutually Exclusive

Question 3

For any two events A and B:

(a) $P(A - B) = P(A) - P(B)$ (b) $P(A - B) = P(A) - P(A \cap B)$
 (c) $P(A - B) = P(B) - P(A \cap B)$ (d) $P(B - A) = P(B) + P(A \cap B)$

Answer: b

Explanation:

$P(A \cup B) = P(A) + P(B) - P(A \cap B)$, and specialize this formula for the case (a) when A, B are mutually exclusive events and for the case (b) where A, B are statistically independent

Question 4

Five Persons A, B, C, D and E are in queue of a shop. The probability that A and E are always together, is

(a) $\frac{1}{4}$ (b) $\frac{2}{3}$
 (c) $\frac{2}{5}$ (d) $\frac{3}{5}$

Answer: c

Explanation:

Total number of person = 5

Total outcome = 5!

A & E come together. $\underline{AE}\bar{2}\bar{3}\bar{4}$

Favorable outcome = $4! \times 2!$

probability $\frac{4! \times 2!}{5!} \left[P = \frac{\text{favorable}}{\text{Total}} \right]$

$= \frac{2}{5}$ option (c) is correct.

Question 5

One card is drawn at random from a pack of 52 cards. What is the probability that the card drawn is a face (Jack, Queen, and King only)?

(a) $\frac{3}{13}$ (b) $\frac{1}{13}$
 (c) $\frac{3}{52}$ (d) $\frac{9}{52}$

Answer: a

Explanation:

Clearly, there are 52 cards, out of which there are 12 face cards.

$P(\text{getting a face card}) = \frac{12}{52} = \frac{3}{13}$.

NOV 2019

Question 1

Two letters are chosen from the word HOME. What is the probability that the letters chosen are not vowels?

- (a) $\frac{2}{3}$ (b) $\frac{1}{6}$
 (c) $\frac{2}{3}$ (d) 0

Answer: b

Explanation:

(b) HOME

Total letters = 4

Total vowels = 2 {O, E}

Total consonants = 2 {H, M}

P (that 2 letters chosen are not vowels) $\frac{2}{4}$

P (that 2 letters chosen are consonants) $\frac{1}{3}$

$\frac{2 \times 4}{1 \times 3} = \frac{1}{6}$ (Required probability)

Question 2

If A, B, C are three mutually exclusive and exhaustive events such that:

$P(A) = 2P(B) = 3P(C)$ what is $P(B)$?

- (a) $\frac{6}{11}$ (b) $\frac{3}{11}$
 (c) $\frac{1}{6}$ (d) $\frac{1}{3}$

Answer: b

Explanation:

(b) Since A, B, C are mutually exclusive events

$P(A \cap B) = 0$, $P(B \cap C) = 0$, $P(C \cap A) = 0$ and $P(A \cap B \cap C) = 0$

Since A, B, C are mutually exhaustive $P(A \cup B) = 1$

We know,

$P(A \cup B) = P(A) + P(B) + P(C) - P(A \cap B) - P(B \cap C) - P(C \cap A) + P(A \cap B \cap C)$

$1 = P(A) + P(B) + P(C) - 0 - 0 + 0$

$P(A) + P(B) + P(C) = 1$

In given question; $P(A) = 2P(B) = 3P(C)$

$P(A) = 2P(B)$

And $P(C) = \frac{2}{3}P(B)$

Put Eq 2 and 3 in Eq 1

$2P(B) + P(B) + \frac{2}{3}P(B) = 1$

$$\frac{11}{3} P(B) = 1$$

$$P(B) = \frac{3}{11}$$

Question 3

What is the probability of getting 7 or 11 when two dices are thrown?

- (a) $\frac{2}{9}$ (b) $\frac{6}{36}$
 (c) $\frac{10}{36}$ (d) $\frac{2}{36}$

Answer: a

Explanation:

(a) When two dices are thrown

$$n(S) = 36$$

A event of getting sum 7

B event of getting sum 11

A {(1, 6), (2, 5), (3, 4), (4, 3), (5, 2), (6, 1)}

$$n(A) = 6$$

B {(5, 6), (6, 5)}

$$n(B) = 2$$

$$P(\text{of getting sum 7 or 11}) = \frac{6+2}{36}$$

$$= \frac{8}{36} = \frac{2}{9}$$

Question 4

A bag contains 15 one rupee coins, 25 two rupee coins if a coin is selected at random than probability for not selecting a one-rupee coin is:

- (a) 0.30 (b) 0.20
 (c) 0.25 (d) 0.70

Answer: d

Explanation:

Given: Bag containing 15 one rupee coin +25 two rupee coin+10 five rupee coin =50 coins in total.

To find: the probability of not selecting a one rupee coin

Sol: The probability of not picking a one-rupee coin is 1 minus the probability of picking a one-rupee coin.

$$\text{Hence the required probability} = 1 - \frac{15}{50} = \frac{35}{50} = 0.7$$

Question 5

Is the required probability of occurring 4 or more than 4 accidents?

No. of acc.	1	2	3	4	5	6	7
Frequency	8	17	15	24	27	18	9

- (a) 24 (b) 69
(c) 78 (d) 80

Answer: c

Explanation:

$$\begin{aligned} \text{(No. of 4 or more accidents)} &= 24 + 27 + 18 + 9 \\ &= 78 \end{aligned}$$

$$\begin{aligned} \text{Total accidents} &= 8 + 17 + 15 + 24 + 27 + 18 + 9 \\ &= 118 \end{aligned}$$

DEC 2020

Question 1

When 2 fair dice are thrown. What is the probability of getting the sum which is a multiple of 3?

- (a) $\frac{4}{36}$ (b) $\frac{8}{36}$
(c) $\frac{2}{36}$ (d) $\frac{12}{36}$

Answer: d

Explanation:

	1	2	3	4	5	6
1	(1, 1)	(1, 2)	(1, 3)	(1, 4)	(1, 5)	(1, 6)
2	(2, 1)	(2, 2)	(2, 3)	(2, 4)	(2, 5)	(2, 6)
3	(3, 1)	(3, 2)	(3, 3)	(3, 4)	(3, 5)	(3, 6)
4	(4, 1)	(4, 2)	(4, 3)	(4, 4)	(4, 5)	(4, 6)
5	(5, 1)	(5, 2)	(5, 3)	(5, 4)	(5, 5)	(5, 6)
6	(6, 1)	(6, 2)	(6, 3)	(6, 4)	(6, 5)	(6, 6)

Favourable outcome is = 12

Hence, $\frac{12}{36}$ is the answer

Question 2

When 3 dice are rolled simultaneously the probability of a number on the third die is greater than the sum of the numbers on two dice.

- (a) $\frac{12}{216}$ (b) $\frac{36}{216}$
(c) $\frac{48}{216}$ (d) $\frac{16}{216}$

Answer: d

Explanation:

Believing all three dice are 'fair' ones.

When three dice are thrown simultaneously; there are $(6 * 6 * 6) = 216$ possible outcomes.

Now, $2 \leq \text{Sum of those appeared on the first two dice} \leq 12$.

But, $1 \leq \text{Number appearing on third die} \leq 6$.

Thus, only the following outcomes on the three dice give the desired result : (1, 1, 3), (1, 1, 4), (1, 2, 4), (2, 1, 4), (1, 1, 5), (1, 2, 5), (1, 3, 5), (2, 1, 5), (3, 1, 5), (1, 1, 6), (1, 2, 6), (1, 3, 6), (1, 4, 6), (2, 1, 6), (3, 1, 6) and (4, 1, 6). Total 16 outcomes.

Thus, the required probability = $(16 / 216) = (2 / 27) = 0.074074$.

Question 3

If A speaks 75% of truth and B speaks 80% of truth. In what percentage both of them likely to contradict with each other in narrating the same questions

- (a) 0.60 (b) 0.45
(c) 0.65 (d) 0.35

Answer: d

Explanation:

A Speak truth 75% i.e., $P(A) = \frac{3}{4}$, $P(\bar{A}) = \frac{1}{4}$

Similarly, B speak truth 80% i.e., $P(B) = \frac{4}{5}$, $P(\bar{B}) = \frac{1}{5}$

While contradicting the narration Probability = $P(A) P(\bar{B}) + P(\bar{A}) P(B)$

$$\frac{3}{4} \times \frac{1}{5} + \frac{1}{4} \times \frac{4}{5}$$

$$\frac{7}{20} = \frac{35}{100} \times 100\% = 35\%$$

Question 4

If two Unbiased Coins are tossed what is Probability of getting at least one tail?

- (a) 1/4 (b) 3/4
(c) 1/2 (d) 2/3

Answer: b

Explanation:

At least one tail

LET A=event of getting at least one tail (HT,TH,TT) $P(A) = \frac{N(A)}{N(S)} = \frac{3}{4}$

IAN 2021

Question 1

Two dice are thrown simultaneously. The probability of a total score of 5 from the outcomes of dice is ‘

- (a) 1/18 (b) 1/12
(c) 1/9 (d) 2/5

Answer: c

Explanation:

If two dice are thrown simultaneously, the total number of sample space is 36

Favourable outcomes = (1, 4), (4, 1), (2, 3) and (3, 2)

Therefore, the required probability = $4 / 36 = 1/9$.

Question 2

If an unbiased coin is tossed twice, then the probability of obtaining at least one tail is ‘

- (a) 1 (b) 0.5
(c) 0.75 (d) 0.25

Answer: c

Explanation:

we know that $P(HHH)+P(HT)+P(TH)+P(TT) = 1$

$P(HT)+P(TH)+P(TT) = 1-P(HH)$

$$= 1 - \frac{1}{4} = \frac{3}{4}$$

$$= 0.75$$

Question 3

If an unbiased coin is tossed three times. What is the probability of getting more than one head?

- (a) $\frac{1}{2}$ (b) $\frac{3}{8}$
(c) $\frac{7}{8}$ (d) $\frac{1}{3}$

Answer: a

Explanation:

Given: coin tossed three times

To find: the probability of getting more than one head Sol: The sample space is {HHH, HHT, HTH, HTT, THH, THT, TTH, TTT}, $n(S)=8$

The favourable outcomes for getting more than one head is {HHH, HHT, HTH, THH}, $n(E)=4$

Hence, the probability of getting more than one head is $\frac{n(E)}{n(S)} = \frac{4}{8} = \frac{1}{2}$

JULY 2021

Question 1

A biased coin is such that the probability of getting a head is thrice the probability of getting a tail. If the coin is tossed 4 times, what is the probability of getting a head all the times?

- (a) $\frac{2}{5}$ (b) $\frac{81}{128}$
(c) $\frac{81}{256}$ (d) $\frac{81}{64}$

Answer: Options (c)

Explanation:

Sample Space = $4 \times 4 \times 4 \times 4 = 256$

\therefore Probability of getting a tail = $\frac{\text{Total favourable outcome}}{\text{Sample Space}} = \frac{81}{256}$

Question 2

If there are 16 phones, 10 of them are Android and 6 of them are of Apple, then the probability of 4 randomly selected phones to include 2 Android and 2 Apple phone is

- (a) 0.47 (b) 0.51
(c) 0.37 (d) 0.27

Answer: Options (c)

Explanation:

∴ Probability of 4 randomly selected phones to include 2 Android and 2 Apple phone

$$= \frac{\text{Total favourable outcome}}{\text{Sample Space}} = \frac{6}{16}$$

Question 3

If there are 48 marbles marked with numbers 1 to 48, then the probability of selecting a marble having the number divisible by 4 is

- (a) 1/2 (b) 2/3
(c) 1/3 (d) 1/4

Answer: Options (b)

Explanation:

Given: Marbles with numbers marked on each of them are 1, 2, 3, 4 ... 48

∴ Probability of selecting a marble having the number divisible by

$$4 = \frac{\text{Total favourable outcome}}{\text{Sample Space}}$$

$$\frac{32}{48} = \frac{2}{3}$$

Question 4

In a class, 40% of the students study math and science. 60% of the students study math. What is the probability of a student studying science given he/she is already studying math?

- (a) 0.25 (b) 0.40
(c) 0.67 (d) 0.60

Answer: Options (c)

Explanation:

$$P(\text{Mands}) = 0.60$$

$$P(M) = 0.60$$

$$P(S|M) = \frac{P(M \text{ and } S)}{P(S)} = \frac{0.40}{0.60} = \frac{2}{3} = 0.67$$

Question 5

A bags contains 7 blue and 5 green balls. One ball is drawn at random. The

probability of getting a Blue ball is

(a) $5/12$

(b) $12/35$

(c) $7/12$

(d) 0

Answer: Options (c)

Explanation:

Number of green balls=5

Number of blue balls=7

Total number of balls=12

Probability of not green balls =number of not green balls/ total number of balls
=7/12.

Question 6

The probability that a football team losing a match at Kolkata is $3/5$ and wining a match at Bengaluru is $6/7$, the probability of the team winning at least one match is

(a) $3/35$

(b) $18/35$

(c) $32/35$

(d) $17/35$

Answer: Options (c)

Explanation:

$P(\text{winning}) + P(\text{losing}) + P(\text{drawing}) = 1$

$3/5 + 6/7 + P(\text{drawing}) = 1$

$P(\text{drawing}) = 32/35$.

DEC 2021

Question 1

For any two dependent events A and B, $P(A) = 5/9$ and $P(B) = 6/11$ and $P(\text{and } P(A \cap B) = 10/33$. What are the values of $P(A/B)$ and $P(B/A)$?

(a) $5/9, 6/11$

(b) $5/6, 6/11$

(c) $1/9, 2/9$

(d) $2/9, 4/9$

Answer: a

Explanation:

$$P(A/B) = \frac{P(A \cap B)}{P(B)} = \frac{10/33}{6/11} = \frac{10}{33} \times \frac{11}{6} = \frac{10}{18} = \frac{5}{9}$$

$$P(B/A) = \frac{10/33}{5/9} = \frac{10}{33} \times \frac{9}{5} = \frac{18}{33} = \frac{6}{11}$$

Question 2

Which of the following pair of events E and F are mutually exclusive?

(a) $E = \{\text{Ram's age is 13}\}$ and $F = \{\text{Ram is studying in a college}\}$

(b) $E = \{\text{Sita a studies in a school}\}$ and $F = \{\text{Sita is a play back singer}\}$

(c) $E = \{\text{Raju is an elder brother in a family}\}$ and $F = \{\text{Raju's father has more than one son}\}$

(d) $E = \{\text{Banu studied B.A. English literature and}\}$ $F = \{\text{Banu can reach English novels}\}$

Answer: a

Explanation:

Two events are said to be mutually exclusive when they cannot appear together, i.e., the probability of both such events occurring together is zero.

From the given options, it is clear that option (a) is the answer, as a 13 year old kid cannot study in college.

Question 3

Assume that the probability for rain on a day is 0.4. An umbrella salesman can earn Rs. 400 per day in case of rain on that day and will lose Rs. 100 per day if there is no rain. The expected earnings in (in Rs.) per day of the salesman is

- (a) 400 (b) 200
(c) 100 (d) 0

Answer: c

Explanation:

x	P	px
400	0.4	160
-100	0.6	-60
		Px= 100

Question 4

The probability distribution of a random variable x is given below:

X:	1	2	4	5	6
P:	0.15	0.25	0.2	0.3	0.1

What is the standard deviation of x?

- (a) 1.49 (b) 1.56
(c) 1.69 (d) 1.72

Answer: c

Explanation:

$$E(x) = \sum px = (1 \times 0.15) + (2 \times 0.25) + (4 \times 0.20) + (5 \times 0.30) + (6 \times 0.10) = 3.55$$

$$E(x^2) = \sum px^2 = (1^2 \times 0.15) + (2^2 \times 0.25) + (4^2 \times 0.20) + (5^2 \times 0.30) + (6^2 \times 0.10) = 15.45$$

$$V(x) = E(x^2) - \{E(x)\}^2 = 15.45 - (3.55)^2 = 2.8475$$

$$\sigma_x: \sqrt{2.8475} = 1.69$$

Question 5

In a group of 20 males and 15 females, 12 males and 8 females are service holders. What is the probability that a person selected at random from the

group is a service holder given that the selected person is a male?

- (a) 0.40 (b) 0.45
(c) 0.60 (d) 0.55

Answer: c

Explanation:

Since the selected person is a male, the total number of outcomes = 20.

Number of Favourable Outcomes = 12

$$\text{Probability} = \frac{\text{Number of Favourable Outcomes}}{\text{Total Number of Outcomes}}$$

$$\text{Probability} = 12/20 = 0.60$$

Question 6

There are 3 boxes with the following composition:

Box I : 7 Red + 5 White + 4 Blue balls

Box II : 5 Red + 6 White + 3 Blue balls

Box III : 4 Red + 3 White + 2 Blue balls

One of the boxes is selected at random and a ball is drawn from it. What is the probability the drawn ball is red?

- (a) 1249/3024 (b) 1247/3004
(c) 1147/3024 (d) 1/2

Answer: a

Explanation:

Case 1 - Box I is drawn.

Probability of drawing Box = 1/3 and

Probability of drawing a red ball from it = 7/16

Case 2 - Box II is drawn. |

Probability of drawing Box II = 1/3 and

Probability of drawing a red ball from it = 5/14

Case 3 - Box III is drawn.

Probability of drawing Box III = 1/3 and

Probability of drawing a red ball from it = 4/9

Therefore,

$$\text{Probability} = \left(\frac{1}{3} \times \frac{7}{16}\right) + \left(\frac{1}{3} \times \frac{5}{14}\right) + \left(\frac{1}{3} \times \frac{4}{9}\right) = 0.4130$$

Now, try the options.

Option (a) - 1249/3024

$$1249 \div 3024 = 0.4130$$

Therefore, option (a) is the answer.

Question 7

For a probability distribution, probability is given by, $P(X_i) = \frac{X_i}{k}$, $X_i = 1, 2, \dots, 9$.

The value of K is

(a) 55

(b) 9

(c) 45

(d) 81

Answer: c**Explanation:**

Note: $P(X) = k$ should be ideally written as $P(X_i) = \frac{X_i}{k}$

We know that sum of Probabilities is 1.

Therefore,

$$\frac{1}{k} + \frac{2}{k} + \frac{3}{k} + \frac{4}{k} + \frac{5}{k} + \frac{6}{k} + \frac{7}{k} + \frac{8}{k} + \frac{9}{k} = 1$$

$$\frac{1 + 2 + 3 + 4 + 5 + 6 + 7 + 8 + 9}{k} = 1$$

We know that sum of first n natural numbers is given by $\frac{n(n+1)}{2}$

Therefore, $\frac{9(9+1)}{2} \div k = 1$

$$\frac{90}{2} \times \frac{1}{k} = 1$$

$$\frac{45}{k} = 1$$

$$k = 45$$

JUNE 2022

Question 1

A dice is rolled twice. Find the probability of getting numbers multiple of 3 or 5 ?

(a) 1/3

(b) 1/4

(c) 1/2

(d) 1/6

Answer: c**Explanation:**

If one dice is rolled twice then

No of sample space n (s) = 36

Events (A) = " getting No is multiple of '3' or '5'

(A) = { (2, 1), (5, 1) (1, 5) (4, 2) (2, 4) (3, 3) (6,3) (3, 6) (5,4) (4, 5) (6, 6), (4, 1) (1, 4) (2, 3) (3, 2) (6, 4) (4, 6) (5, 5)}

n (A) = 18

$$P (A) = \frac{n(A)}{n(S)} = \frac{18}{36} = \frac{1}{2}$$

Question 2

What is the probability of occurrence of leap year having 53 Sunday?

(a) 1/7

(b) 2/7

(c) 3/7

(d) 4/7

Answer: b**Explanation:**

There are 366 days in a year
2 days may be

- (i) Sunday & Monday
- (ii) Monday & Tuesday
- (iii) Tuesday & Wednesday
- (iv) Wednesday & Thursday
- (v) Thursday & Friday
- (vi) Friday & Saturday
- (vii) Saturday & Sunday

Here $n(S) = 7$

$n(A) = 2$

$$P(A) = \frac{n(A)}{n(S)} = \frac{2}{7}$$

Question 3

If in a bag of 30 balls numbered from 1 to 30. Two balls are drawn find probability of getting a ball being multiple of 2 or 5

(a) 108/465

(b) 117/435

(c) 117/300

(d) 116/485

Answer: b**Explanation:**

In a bag of 30 balls numbered
From '1 to 30'. If two balls are
drawn from the bag then

sample space $n(S) = {}^{30}C_2$

$$= \frac{30 \times 29}{2 \times 1} = 435$$

A getting ball No as multiple of 2

$$n(A) = {}^{15}C_2 = \frac{15 \times 14}{2 \times 1} = 105$$

$$P(A) = \frac{105}{435}$$

B- getting ball No as multiple of 5

$$n(B) = {}^6C_2 = \frac{6 \times 5}{2 \times 1} = 15$$

$$P(B) = \frac{15}{435}$$

$A \cap B$ getting ball No is multiple of 3 and 5 (10)

$$n(A \cap B) = {}^3C_2 = 3$$

$$P(A \cap B) = \frac{3}{435}$$

$$P(2' \text{ or } 5') = P(A \cup B)$$

$$\begin{aligned}
 &= P(A) + P(B) - P(A \cap B) \\
 &= \frac{105}{435} + \frac{15}{435} - \frac{3}{435} \\
 &= \frac{105 + 15 - 3}{436} \\
 &= \left(\frac{117}{435} \right)
 \end{aligned}$$

Question 4

Two perfect dice are rolled what is the probability that one appears at least in one of the dice?

- (a) $7/36$ (b) $11/36$
 (c) $9/36$ (d) $15/36$

Answer: b

Explanation:

If two dice are Rolled then sample space $n(s) = 36$

Event 'A "getting '1' appears at least in one of the dice"

{ (1,2) (1,3) (1,4) (1,5) (1,6) (1,1) (2,1) (3,1) (4, 1) (5, 1) (6, 1) }

$n(A) = 11$

$$P(A) = \frac{n(A)}{n(S)} = \frac{11}{36}$$

Question 5

If two dice are rolled and one of the dice shows 1 at a point then how many such outcome can be done where it is known that its probability is $\frac{x}{36}$, where $x = \underline{\hspace{1cm}}$.

- (a) 11 (b) 7
 (c) 8 (d) 9

Answer: a

Explanation:

If two dice are Rolled then sample space $n(s) = 36$

Event (A) = "getting one of the dice show as 1"

= { (1,1) (1,2) (1,3) (1,4) (1,5) (1,6) (2,1) (3,1) (4,1) (5,1) (6,1) }

$n(A) = 11$

Question 6

If $P(A) = 0.3$; $P(B) = 0.8$ and $P\left(\frac{B}{A}\right) = 0.5$, find $P(A \cup B)$

- (a) 0.85 (b) 0.95
 (c) 0.55 (d) 0.5

Answer: b**Explanation:**Given $P(A) = 0.3$, $P(B) = 0.8$, $P(B/A) = 0.5$

$$P(B/A) = \frac{P(A \cap B)}{P(A)}$$

$$0.5 = \frac{P(A \cap B)}{0.3}$$

$$P(A \cap B) = 0.5 \times 0.3 = 0.15$$

$$P(A \cup B) = P(A) + P(B) - P(A \cap B)$$

$$= 0.3 + 0.8 - 0.15$$

$$= 1.10 - 0.15 = 0.95$$

Question 7**If P Q are the odds in favour of an event, then the probability of that event is**

(a) p/q

(b) $\frac{p}{p+q}$

(c) $\frac{q}{p+q}$

(d) q/p

Answer: b**Explanation:**If odd in favour of an event = $p : q$ Then Probability of success $P(A) = \frac{p}{(p+q)}$

DEC 2022

Question 1**A machine is made of two parts A and B. The manufacturing Process of each part is such that probability of defective in part A is 0.08 and that B is 0.05. What is the probability that the assembled part will not have any defect?**

a) 0.934

b) 0.864

c) 0.85

d) 0.874

Answer: Options (b)**Explanation:**Probability of Defective Part a = $9/100$ Probability of non-defective of a = $1 - 9/100 = 91/100$ Probability of Defective Part b = $5/100 = 1/20$ Probability of non-defective part b = $1 - 1/20 = 19/20$

Assembly will not be defective if both part are non-defective

$$= (91/100) \times (19/20)$$

$$= 1729/2000$$

$$= 0.8645$$

Question 7

If three coins are tossed simultaneously, what is the probability of getting two heads together?

a) $1/4$ b) $1/8$ c) $5/8$ d) $3/8$ **Answer: Options (d)****Explanation:**

When three coins are tossed then the outcome will be any one of these combinations. (TTT, THT, TTH, THH, HTT, HHT, HTH, HHH).

So, the total number of outcomes is 8.

Now, for exactly two heads, the favorable outcome is (THH, HHT, HTH). We can say that the total number of favorable outcomes is 3.

Again, from the formula

Probability = Number of favorable outcomes/Total number of outcomes
Probability = $3/8$

- The probability of getting exactly two heads is $3/8$.

CHAPTER - 16 THEORETICAL DISTRIBUTIONS

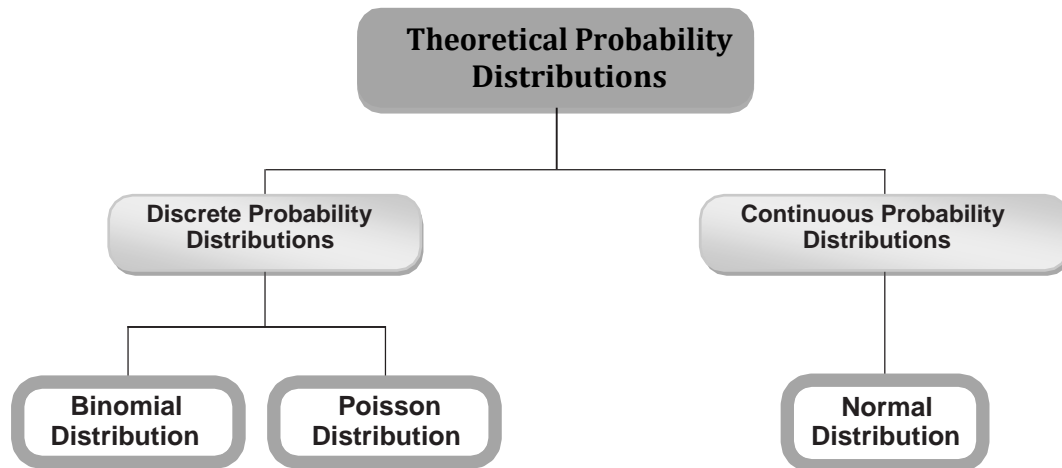

THEORETICAL PROBABILITY	The total probability (i.e. one) is distributed to different mass points in case of a discrete random variable or to different class intervals In case of a continuous random variable
BINOMIAL DISTRIBUTION	<p>One of the most important and frequently used discrete binomial distribution.</p> <p>The binomial distribution is a common discrete distribution used in statistics, as opposed to a continuous distribution such as the normal distribution. This is because the binomial distribution only counts two states, typically represented as 1 (for a success) or 0 (for a failure) given a number of trials in the data</p>
POISSON DISTRIBUTION	<p>A random variable X is defined to follow Poisson distribution with parameter, to be denoted by $X \sim P(\lambda)$ if the probability mass function of x</p> <div style="border: 1px solid black; padding: 10px; text-align: center;"> <p>Poisson Distribution Formula</p> $P(X = x) = \frac{\lambda^x e^{-\lambda}}{x!}$ <p>where $x = 0, 1, 2, 3, \dots$ λ = mean number of occurrences in the interval e = Euler's constant ≈ 2.71828</p> </div>

NORMAL DISTRIBUTIONS

NORMAL DISTRIBUTIONS

If a continuous random variable has a distribution with a graph that is symmetric and bell-shaped and can be described by the equation

$$y = \frac{e^{-\frac{1}{2}\left(\frac{x-\mu}{\sigma}\right)^2}}{\sigma\sqrt{2\pi}}$$

we say that it has a **normal distribution**.

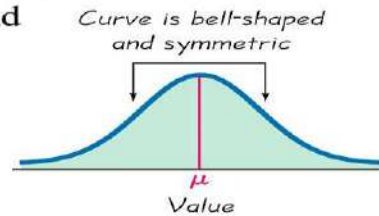

Properties of the Normal Distribution

- ❑ The normal distribution curve is **bell-shaped**.
- ❑ The mean, median, and mode are **equal** and located at the center of the distribution.
- ❑ The normal distribution curve is **unimodal** (single mode).
- ❑ The curve is **symmetrical** about the mean.
- ❑ The curve is **continuous**.
- ❑ The curve **never touches the x-axis**.
- ❑ The total area under the normal distribution curve is **equal to 1 or 100%**.

STANDARD NORMAL DISTRIBUTION

The Standard Normal Distribution

- If each data value of a normally distributed random variable x is transformed into a z -score, the result will be the standard normal distribution.

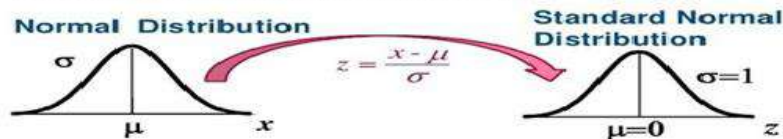

- Use the Standard Normal Table to find the cumulative area under the standard normal curve.

POISSON DISTRIBUTION:

Question1

In a Poisson Distribution, if 'n' is the number of trials and 'p' is the probability of success, then the mean value is given by

(a) $m = n p$

(b) $m = (np)^2$

For more Info Visit - www.KITest.in

(c) $m = n p (1-p)$

(d) $m = p$

Answer: a**Explanation:**

For a discrete probability function, the mean value or the expected value is given by

Mean (μ) = $\sum_{x=0}^n x p(x)$

For Poisson Distribution $P(x) = \frac{e^{-m} m^x}{x!}$ substitute in above equation and solve to get $\mu = m = n p$.**Question 2****If 'm' is the mean of A Poisson Distribution, then variance is given by**

(a) m^2

(b) $m^{\frac{1}{2}}$

(c) m

(d) $m/2$

Answer: c**Explanation:**

For a discrete probability function, the variance is given by

Variance (v) = $\sum_{x=0}^n x^2 p(x) - \mu^2$

Where μ is the mean, substitute $P(x) = \frac{e^{-m} m^x}{x!}$, in the above equation and put $\mu = m$ to obtain

$V = m$.

Question 3**The p.d.f of Poisson distribution is given by**

(a) $\frac{e^{-m} m^x}{x!}$

(b) $\frac{e^{-m} x!}{m^x}$

(c) $\frac{x!}{m^x e^{-m}}$

(d) $\frac{e^m m^x}{x!}$

Answer: a**Explanation:**

This is a standard formula for Poisson distribution, it needs no explanation. Even though if you are interested to know the derivations in detail, you can refer to any of the books or source on internet that speaks of this matter.

Question 4**If 'm' is the mean of a Poisson distribution, the standard deviation is given by**

(a) $m^{1/2}$

(b) m^2

(c) m

(d) $m/2$

Answer: a**Explanation:**The variance of a Poisson distribution with mean 'm' is given by $V = m$, hence standard

Deviation = $(\text{Variance})^{1/2} = m^{1/2}$

Question 5**In a Poisson distribution the mean and variance are equal**

(a) True

(b) False

(c) Can't say

(d) Not justifiable

Answer: a**Explanation:**

Mean = m

Variance = m

∴ Mean = Variance.

Question 6

In a Poisson distribution, if mean (m) = e, then P(x) is given by

- (a) $\frac{e^{-m}m^x}{x!}$ (b) $\frac{e^{-m}x!}{m^x}$
 (c) $\frac{x!}{m^x e^{-m}}$ (d) $\frac{e^m m^x}{x!}$

Answer: a

Explanation:

Put m = e.

$$P(x) = \frac{e^{-m}m^x}{x!}$$

Question 7

Poisson distribution is applied for

- (a) Continuous Random variable (b) Discrete Random variable
 (c) Irregular Random variable (d) Uncertain Random Variable

Answer: b

Explanation:

Poisson distribution along with Binomial Distribution is applied for discrete Random variable. Speaking more precisely, Poisson Distribution is an extension of Binomial Distribution for larger values 'n'. since Binomial Distribution is of discrete nature, so is its extension Poisson Distribution.

Question 8

If 'm' is the mean of Poisons Distribution, the P(0) is given by

- (a) e^{-m} (b) e^m
 (c) e (d) m^{-e}

Answer: a

Explanation:

$$P(x) = \frac{e^{-m}m^x}{x!}$$

Put x = 0, to obtain e^{-m} .

Question 9

In a Poisson distribution, the mean and standard deviation are equal

- (a) True (b) False
 (c) Can't say (d) Not justified

Answer: b

Explanation:

In a Poisson distribution,

Mean = m

Standard deviation = $m^{1/2}$

∴ Mean and Standard deviation are not equal.

Question 10

For a Poisson distribution, if mean (m) = 1, then P(1) is

- (a) $\frac{1}{e}$ (b) e
 (c) $\frac{e}{2}$ (d) Indeterminate

Answer: a**Explanation:**

$$P(x) = \frac{e^{-m} m^x}{x!}$$

Put $m = x = 1$, (given) to obtain $1/e$.**Question 11****The recurrence relation between $P(x)$ and $P(x+1)$ in a Poisson distribution is given by**

(a) $P(x+1) - m P(x) = 0$

(b) $m P(x+1) - P(x) = 0$

(c) $(x+1) P(x+1) - m P(x) = 0$

(d) $(x+1) P(x) - x P(x+1) = 0$

Answer: c**Explanation:**

$$P(x) = \frac{e^{-m} m^x}{x!}$$

$$P(x+1) = e^{-m} \frac{m^{x+1}}{(x+1)!}$$

Divide $P(x+1)$ by $P(x)$ and rearrange to obtain $(x+1) P(x+1) - m P(x) = 0$.**Question 12****The mean value for an event X to occur is 2 in a day. Find the probability of event X to occur thrice in a day.**

(a) 0.1804

(b) 0.1804465

(c) 0.18

(d) None

Answer: b**Explanation:**Mean, $m = 2$ $x = 3$ Probability of the event to occur thrice, $P(3; 2) = e^{-2} \frac{2^3}{3!} = 0.1804465$ **Question 13****A man was able to complete 3 files a day on an average. Find the probability that he can complete 5 files the next day.**

(a) 0.108

(b) 0.1008

(c) 0.008

(d) None

Answer: b**Explanation:**

Here we know this is a Poisson experiment with following values given:

 $\mu = 3$, average number of files completed a day $X = 5$, the number of files required to be completed next dayAnd $e = 2.71828$ being a constant

On substituting the values in the Poisson distribution formula mentioned above we get the Poisson probability in this case.

We get

$$P(x, \mu) = \frac{(e^{-\mu})(\mu^x)}{x!}$$

$$\rightarrow P(5, 3) = \frac{(2.71828)^{-3} (3^5)}{5!}$$

$$= 0.1008 \text{ approximately.}$$

Hence the probability for the person to complete 5 files the next day is 0.1008 approximately.

Question 14

The number of calls coming per minute into a hotels reservation center is Poisson random variable with mean 3. Find the probability that no calls come in a given 1-minute period

- (a) e^{-3} (b) e^3
 (c) e (d) m^{-e}

Answer: a

Explanation:

Let x denote the number of calls coming in that given 1 minute period. $X \sim \text{Poisson}(3)$

$$P(x = 0) = \frac{e^{-3} 3^0}{0!}$$

$$= e^{-3}$$

Question 15

If the random variable X follows a Poisson distribution with mean 3,4, find $P(x=6)$

- (a) 0.071604409 (b) 0.00125948
 (c) 0.0023698 (d) 0.015792

Answer: a

Explanation:

This can be written more quickly as: if $X = \text{Po}(3,4)$

Find $P(x = 6)$

Now

$$P(x = 6) = \frac{e^{-\lambda} \lambda^6}{6!}$$

$$= \frac{e^{-3.4} (3.4)^6}{6!} \text{ (mean, } \lambda = 3.4)$$

$$= 0.071604409 \text{ or } 0.072 \text{ (to 3 d.p.)}$$

BINOMIAL DISTRIBUTION:

Question 1

In a binomial Distribution, 'if 'n' is the number of trials and 'p' is the probability of success, then the mean value is given by

- (a) np (b) n
 (c) p (d) np(1 - p)

Answer: a

Explanation:

For a discrete probability function, the mean value or the expected value is given by

$$\text{Mean } (\mu) \sum_{x=0}^n xp(x)$$

For Binomial Distribution $P(x) = {}^n C_x p^x q^{(n-x)}$, substitute in the above equation and solve to get $\mu = np$.

Question 2

In the Binomial Distribution, If p, q and n are probability of success, failure and number of trials respectively then variance is given by

- (a) np (b) npq
 (c) np²q (d) npq²

Answer: b

Explanation:

For a discrete probability function, the variance is given by

$$\text{Variance (V)} = \sum_{x=0}^n x^2 p(x) - \mu^2$$

Where μ is the mean, substitute $P(x) = P(X = x) = {}^n C_x p^x q^{(n-x)}$, in the above equation and put $\mu = np$ to obtain

$$V = npq.$$

Question 3

If 'x' is a random variable, taking values 'x' probability of success and failure being 'p' and 'q' respectively and 'n' trials being conducted, then what is the probability that 'x' takes values 'x'? Use Binomial Distribution

(a) $P(X = x) = {}^n C_x p^x q^x$

(b) $P(X = x) = {}^n C_x p^x q^{(n-x)}$

(c) $P(X = x) = {}^n C_x p^x q^{(n-x)}$

(d) $P(X = x) = {}^n C_x p^x q^x$

Answer: b

Explanation:

It is the formula for Binomial Distribution that is asked here which is given by $P(X = x) = {}^n C_x p^x q^{(n-x)}$

Question 4

If 'p', 'q' and 'n' are probability of success, failure and number of trials respectively in a Binomial Distribution, what is its standard Deviation?

(a) $(np)^{1/2}$

(b) $(pq)^{1/2}$

(c) $(np)^2$

(d) $(npq)^{1/2}$

Answer: d

Explanation:

The variance (V) for a Binomial Distribution is given by $V = npq$

Question 5

In a Binomial Distribution, the mean and variance are equal

(a) True

(b) False

(c) can't say

(d) Not justifiable

Answer: b

Explanation:

Mean = np

Variance = npq

∴ Mean and Variance are not equal.

Question 6

It is suitable to use Binomial Distribution only for

(a) Large value of 'n'

(b) Fractional values of 'n'

(c) Small values of 'n'

(d) Any values 'n'

Answer: c

Explanation:

As the value of 'n' increase, It becomes difficult and tedious to calculate value of ${}^n C_x$.

Question 7

For larger values of 'n' Binomial Distribution

(a) Loses its discreteness

(b) Tends to Poisson Distribution

(c) Stays as it is

(d) Gives oscillatory values

Answer: b

Explanation:

Where $m = np$ is the mean of Poisson Distribution.

Question 8

In a Binomial Distribution, if $p = q$, then $P(X = x)$ is given by

- (a) ${}^n C_x (0.5)^n$ (b) ${}^x C_n (0.5)^n$
 (c) ${}^n C_x p^{(n-x)}$ (d) ${}^x C_n p^{(n-x)}$

Answer: a

Explanation:

If $p = q$ then $p = 0.5$

Substituting in $P(x) = {}^n C_x p^x q^{(n-x)}$ we get ${}^n C_x (0.5)^n$.

Question 9

Binomial Distribution is a

- (a) Continuous distribution (b) Discrete distribution
 (c) Irregular distribution (d) Not a Probability distribution

Answer: b

Explanation:

It is applied to a discrete Random variable, hence it is discrete distribution

Question 10

15 dates are selected at random, what is the probability of getting two Sundays?

- (a) 0.29 (b) 34
 (c) 56 (d) 78

Answer: a

Explanation:

If X denotes the number at Sundays. Then it is obvious that X follows binomial distribution with parameter $n = 15$ and $p =$ probability of a Sunday in a week $= \frac{1}{7}$ and $q = 1 - p = \frac{6}{7}$

$$\text{Then } f(x) = {}^{15} C_x \left(\frac{1}{7}\right)^x \cdot \left(\frac{6}{7}\right)^{15-x}$$

For $x = 0, 1, 2, \dots, 15$.

Hence the probability of getting two Sundays

$$= f(2)$$

$$= {}^{15} C_2 \left(\frac{1}{7}\right)^2 \cdot \left(\frac{6}{7}\right)^{15-2}$$

$$= \frac{10^5 \times 6^{13}}{7^{15}}$$

$$= 0.29$$

Question 11

The incidence of occupational disease in an industry is such that the workmen have a 10% chance of suffering from it. What is the probability that out of 5 workmen, 3 or more will contract the disease?

- (a) 890 (b) .0086
 (c) .00086 (d) None

Answer: c

Explanation;

Let x denote the number of workmen in the sample. X follows binomial with parameters $n = 5$ and $p =$ probability that a workman suffers from the occupational disease $= 0.1$

Hence $q = 1 - 0.1 = 0.9$

Thus $f(x) = {}^5C_x (0.1)^x \cdot (0.9)^{5-x}$

For $x = 0, 1, 2, \dots, 5$.

The probability that 3 or more workmen will contract the disease

$$\begin{aligned} &= P(x \geq 3) \\ &= f(3) + f(4) + f(5) \\ &= {}^5C_3 (0.1)^3 (0.9)^{5-3} + {}^5C_4 (0.1)^4 \cdot (0.9)^{5-4} + {}^5C_5 (0.1)^5 \\ &= 10 \times 0.001 \times 0.81 + 5 \times 0.0001 \times 0.9 + 1 \times 0.00001 \\ &= 0.0081 + 0.00045 + 0.00001 \\ &= 0.0086. \end{aligned}$$

Question 12

Find the probability of a success for the binomial distribution satisfying the following relation $4P(x = 4) = P(x = 2)$ and having the parameter n as six.

- (a) $P \neq 1$ (b) $P \neq -1$
 (c) $P = 1$ (d) $P = 0$

Answer: b

Explanation:

We are given that $n = 6$. The probability mass function of x is given by

$$f(x) = {}^nC_x p^x q^{n-x} = {}^6C_x p^x q^{6-x}$$

For $x = 0, 1, \dots, 6$,

$$\begin{aligned} \text{Thus } P(x = 4) &= f(4); \\ &= {}^6C_4 p^4 q^{6-4} = 15 p^4 q^2 \end{aligned}$$

$$\begin{aligned} \text{And } P(x = 2) &= f(2) \\ &= {}^6C_2 p^2 q^{6-2} = 15 p^2 q^4 \end{aligned}$$

$$\text{Hence } 4P(x = 4) = P(x = 2)$$

$$\begin{aligned} &= 60 p^4 q^2 = 15 p^2 q^4 \\ &= 15 p^2 q^2 (4p^2 - q^2) = 0 \\ &= 4p^2 - q^2 = 0 \text{ (as } p \in [0, 1], q \in [0, 1]) \\ &= 4p^2 - (1 - p)^2 = 0 \text{ (as } q = 1 - p) \\ &= (2p + 1 - p) = 0 \text{ or } (2p - 1 + p) = 0 \\ &= p = -1 \text{ or } p = \frac{1}{3} \text{ thus } p = \frac{1}{3} \text{ (as } p \neq -1) \end{aligned}$$

NORMAL DISTRIBUTION:

Question 1

Normal distribution is applied for

- (a) Continuous Random Distribution (b) Discrete Random Variable
 (c) Irregular Random Variable (d) Uncertain Random Variable

Answer: a

Explanation:

Normal Distribution is applied for Continuous Random Distribution. A discrete probability distribution is a probability distribution characterized by a probability mass function. Thus, the distribution of a random variable x is discrete, and x is called a discrete random variable, if, as x runs through the set of all possible values of x .

Question 2**The shape of the Normal curve is**

- (a) Bell shaped (b) Flat
(c) Circular (d) Spiked

Answer: a**Explanation:**

Due to the nature of the probability Mass function, a bell shaped curve is obtained.

Question 3**Normal Distribution is symmetric is about**

- (a) Variance (b) Mean
(c) Standard deviation (d) Covariance

Answer: b**Explanation:**

Due to the very nature of p.m.f of Normal Distribution, the graph appears such that it is symmetric about its mean.

Question 4**For a standard normal variate, the value of mean is**

- (a) ∞ (b) 1
(c) 0 (d) Not defined

Answer: c**Explanation:**

For a normal variate, if its mean = 0 and standard deviation = 1, then its called as standard Normal variate. Here, the converse is asked.

Question 5**The area under a standard normal curve is**

- (a) 0 (b) 1
(c) ∞ (d) Not defined

Answer: b**Explanation:**

For any probability distribution, the sum of all probabilities is 1. Area under normal curve refers to sum of all probabilities.

Question 6**The standard normal curve is symmetric about the value.**

- (a) ∞ (b) 0
(c) 0.5 (d) 1

Answer: b**Explanation:**

Normal curve is always symmetric about mean, for standard normal curve or variate mean = 0.

Question 7**For a standard normal variate. The value of standard deviation is**

- (a) 3 (b) 1
(c) ∞ (d) Not defined

Answer: b

Explanation:

If the mean and standard deviation of a normal variate are 0 and 1 respectively, it is called as standard normal variate.

Question 8

Normal Distribution is also known as

- (a) Cauchy's Distribution (b) Laplacian Distribution
(c) Gaussian Distribution (d) Lagrangian Distribution

Answer: c

Explanation:

Named after the one who proposed it. For further details, refer to books or internet.

Question 9

Skewers of Normal distribution is

- (a) Negative (b) Positive
(c) 0 (d) Undefined

Answer: c

Explanation:

Since the normal curve is symmetric about its mean, its skewness is zero. This is a theoretical explanation for mathematical proofs, you can refer to books or website that speak on the same in detail.

Question 10

For a normal distribution its mean, median, mode are equal

- (a) True (b) False
(c) Not defined (d) Can't say

Answer: a

Explanation:

It has theoretical evidence that requires some serious background on several topics for more details you can refer to any book or website that speaks on the same.

Question 11

In Normal distribution, the highest value of ordinate occurs at

- (a) Mean (b) Variance
(c) Extremes (d) Same value occurs at all points

Answer: a

Explanation:

This is due the behavior of the pdf of Normal distribution.

Question 12

The shape of the normal curve depends on its

- (a) Mean deviation (b) Standard deviation
(c) Quartile deviation (d) None of these

Answer: b

Explanation:

This can be seen in the pdf on the normal distribution where standard deviation is a variable.

Question 13

The value of constant 'e' appearing in normal distribution is

- (a) 2.5185 (b) 2.7836

(c) 2.1783

(d) None of these

Answer: c**Explanation:**

This is a standard constant.

Question 14**In standard normal distribution, the value of median is**

(a) 1

(b) 0

(c) 2

(d) Not fixed

Answer: b**Explanation:**

In a standard normal distribution the value of mean is 0 and in normal distribution mean, median and mode coincide.

Question 15**In a certain book, the frequency distribution of the number of words per page may be taken as approximately normal with mean 800 and standard deviation 50. If three pages are chosen at random, what is the probability that none of them has between 830 and 845 words each?**

(a) 0.7536

(b) .7654

(c) .9084

(d) .8733

Answer: a**Explanation:**Let X be a normal variate which denotes the number of words per page. It is given that $X \sim N(800, 50)$.

The probability that a page, select at random, does not have number of words between 830 and 845, is given by

$$1 - P(830 < X < 845) = 1 - P\left(\frac{830-800}{50} \leq \leq \frac{845-800}{50}\right)$$

$$= 1 - P(0.6 < \leq < 0.9) = 1 - P(0 < \leq < 0.9) + P(0 < \leq < 0.6)$$

$$= 1 - 0.3159 + 0.2257 = 0.9098 = 0.91$$

Thus, the probability that none of the three pages, selected at random, have number of words lying between 830 and 845 = $(0.91)^3 = 0.7536$.**Question 16****The distribution of 1,000 examines according to marks percentage is given below:**

% Marks	less than 40	40-75	75 or more	Total
No. of examines	430	420	150	1000

Assuming the marks percentage to follow a normal distribution, calculate the mean and standard deviation of marks. If not more than 300 examines are to fail, what should be the passing marks?

(a) 30%

(b) 40%

(c) 50%

(d) None

Answer: a**Explanation:**

Let X denotes the percentage of marks and its mean and S.D. be m and s respectively. From the given table, we can write

 $P(x < 40) = 0.43$ and $P(X \geq 75) = 0.15$, which can also be written as

$$P\left(= < \frac{40-\mu}{\sigma}\right) = 0.43 \text{ and } P\left(= \geq \frac{75-\mu}{\sigma}\right) = 0.15$$

The above equations respectively imply that

$$\frac{40-\mu}{\sigma} = -0.175 \text{ or } 40 - \mu = -0.175\sigma \quad \dots (1)$$

$$\text{And } \frac{75-\mu}{\sigma} = 1.04 \text{ or } 75 - \mu = 1.04\sigma \quad \dots (2)$$

Solving the above equations simultaneously, we get $\mu = 45.04$ and $\sigma = 28.81$

Let x , be the percentage or marks required to pass the examination.

$$\text{Then we have } P(x < x_1) = 0.3 \text{ or } P\left(= < \frac{x_1-45.04}{28.81}\right) = 0.3$$

$$\therefore \frac{x_1-45.04}{28.81} = -0.525 \rightarrow x_1 = 29.91 \text{ or } 30\% \text{ (approx)}$$

Question 17

At a petrol station, the mean quantity of petrol sold to a vehicle is 20 litres per day with a standard deviation of 10 liters. If on a particular day, 100 vehicles took 25 or more litres of petrol, estimate the total number of vehicles who took petrol from the station on the day. Assume that the quantity of petrol taken from the station by a vehicle is a normal variate.

- (a) 333 (b) 343
(c) 324 (d) 567

Answer: c

Examination:

Let X denote the quantity of petrol taken by a vehicle. It is given that $X \sim N(20, 10)$.

$$\begin{aligned} \therefore P(X \geq 25) &= P\left(= \geq \frac{25-20}{10}\right) = P(= \geq 0.5) \\ &= 0.5000 - P(0 \leq z \leq 0.5) = 0.5000 - 0.1915 = 0.3085 \end{aligned}$$

Let N be the total number of vehicles taking petrol on that day.

$$\therefore 0.3085 \times N = 100 \text{ or } N = \frac{100}{0.3085} = 324 \text{ (approx.)}$$

Question 18

Using the table areas under the standard normal curve, find the following probabilities:

(i) $P(0 \leq z \leq 1.3)$

(ii) $P(-1 \leq z \leq 0)$

(iii) $P(-1 \leq z \leq 1.2)$

- (a) 0.4032, 0.3413, 0.8185 (b) 0.4072, 0.4413, 0.8185
(c) 0.40456, 0.3456, 0.8155 (d) None

Answer: a

Explanation:

The required probability, in each question, is indicated by the shaded area of the corresponding figure.

(a) From the table.

(b) (i) we can write $P(0 \leq z \leq 1.3) = 0.4032$.

(c) (ii) we can write $P(-1 \leq z \leq 1)$, because the distribution is symmetrical.

Question 19

Determine the value or values of z in the following situations:

(i) Area between 0 and z is 0.4495.

(ii) Area between $-\infty$ to z is 0.1401.

- (a) -1.64, -1.08 (b) -1.08, -1.64

(c) 1.64, 1.08

(d) -1.64, 1.08

Answer: a**Explanation:**

(i) On locating the value of z corresponding to an entry of area 0.4495 in the table of areas under the normal curve, we have $z = 1.64$ we note that same situations may correspond to a negative value of z . Thus, z can be 1.64 or -1.64 .

(ii) Since the area between $-\infty$ to $z < 0.5$, z will be negative. Further, the area between z and $0 = 0.5000 - 0.1401 = 0.3599$. On locating the value of z corresponding to this entry in the table, we get $z = -1.08$

PAST EXAMINATION QUESTIONS:

MAY 2018

Question 1

The variance of a binomial distribution with the parameters n and p is:

(a) $np^2(1-p)$

(b) $nq(1-q)$

(c) $\sqrt{np - (1-p)}$

(d) $n^2p^2(1-p)^2$

Answer: b**Explanation:**

$$= npq$$

$$= nqp$$

$$= nq(1-q)$$

Question 2

X is a poisson variate satisfying the following condition $9 P(X = 4) + 90 P(X = 6) = P(X = 2)$. What is the value of $P(X \leq 1)$?

(a) 0.5655

(b) 0.5655

(c) 0.7358

(d) 0.8835

Answer: c**Explanation:**Given $X \sim P(m)$

$$P(X = 2) = 9 P(X = 4) + 90 P(X = 6)$$

$$\frac{e^{-m} \cdot m^2}{2!} = + \frac{9 \cdot e^{-m} \cdot m^4}{4!} + \frac{90 \cdot e^{-m} \cdot m^6}{2!}$$

$$\frac{90 \cdot e^{-m} \cdot m^6}{2!} + \frac{9 \cdot e^{-m} \cdot m^4}{4!} - \frac{e^{-m} \cdot m^2}{2!} = 0$$

$$e^{-m} \cdot m^2 \left[\frac{90 \cdot m^4}{6!} + \frac{9m^2}{4!} - \frac{1}{2!} \right] = 0$$

$$e^{-m} \cdot m^2 \left[\frac{90 \cdot m^4}{6!} + \frac{9m^2}{4!} - \frac{1}{2!} \right] = 0$$

$$e^{-m} \cdot m^2 \left[\frac{90 \cdot m^4}{6!} + \frac{9m^2}{4!} - \frac{1}{2!} \right] = 0$$

$$e^{-m} \cdot m^2 \left[\frac{m^4}{8} + \frac{3m^2}{8} - \frac{1}{2} \right] = 0$$

$$\frac{e^{-m}}{2} \left[\frac{m^4 + 3m^2 - 4}{4} \right] = 0$$

$$\frac{e^m \cdot m^2}{8} (m^4 + 3m^2 - 4) = 0$$

$$m^4 + 4m^2 - m^2 - 4 = 0$$

$$m^2 (m^2 + 4) - 1 (m^2 + 4) = 0$$

$$(m^2 + 4) (m^2 - 1) = 0$$

$$\text{If } m^2 + 4 = 0 \quad \text{if } m^2 - 1 = 0$$

$$m^2 = -4 \text{ if } \quad m^2 = +1$$

$$m^2 = \neq \sqrt{1}$$

$$m = (\because m > 0)$$

$$P(x \leq 1) = P(x = 0) + P(x = 1)$$

$$= \frac{e^{-1} \cdot 1^0}{0!} + \frac{e^{-1} \cdot 1!}{1!} = \frac{1}{e} + \frac{1}{e} = \frac{2}{e}$$

$$\frac{2}{2.7182} = 0.7358$$

Question 3

What is the first quartile of x having the following probability of function?

$$f(x) = \frac{1}{\sqrt{72x}} e^{-(x-10)^{\frac{2}{72}}} \text{ for } -\infty < x < \infty$$

(a) 4

(b) 5

(c) 5.95

(d) 6.75

Answer: c

Explanation:

$$\text{Given: } f(x) = \frac{1}{\sqrt{72x}} e^{-(x-10)^{\frac{2}{72}}} \text{ for } -\infty < x < \infty$$

$$f(x) = \frac{1}{\sqrt{72x}} e^{-(x-10)^{\frac{2}{72}}}$$

on company

$$f(x) = \frac{1}{\sqrt{2x}} e^{-\frac{(x-\mu)^2}{2(\sigma^2)^2}}$$

we get

$$\sigma = 6, \mu = 10$$

$$\text{First quartile } Q_1 = \mu - 0.675\sigma$$

$$= 10 - 0.675 \times 6$$

$$= 10 - 4.05$$

$$= 5.95$$

Question 4

An example of bi-parametric discrete probability distribution is

- (a) Binomial distribution (b) Poisson distribution
(c) Normal distribution (d) Both a and b

Answer: d

Explanation:

Binomial distribution is an example of a bi- parametric discrete probability distribution.

Question 5

Probability distribution may be

- (a) Discrete (b) Continuous
(c) Infinite (d) a or b

Answer: d

Explanation:

Probability distribution may be discrete or continuous.

Question 6

If the area of standard normal curve between $z = 0$ to $z = 1$ is 0.3413, then the value of $\Phi(1)$ is.

- (a) 0.5000 (b) 0.8413
(c) -0.5000 (d) 1

Answer: b

Explanation:

The area of standard of normal curve between $z = 0$ to $z = 1$ is 0.3413 then

$$\Phi(1) = 0.3413 + 0.5$$

$$0.8413$$

NOV 2018

Question 1

For a poisson variate X, $P(X = 2) = 3P(X = 4)$, then the standard deviation of X is

- (a) 2 (b) 4
(c) $\sqrt{2}$ (d) 3

Answer: c

Explanation:

For Poisson Variate X,

$$\frac{e^{-m}m^2}{2!} = \frac{3e^{-m}m^4}{4!}$$

$$\frac{m^2}{2} = \frac{3m^4}{4!}$$

$$6m^4 = 24 m^2$$

$$m^2 = \frac{24}{6}$$

$$m^2 = 4$$

$$m = 2$$

$$\text{S.D.} = \sqrt{m} = \sqrt{2}$$

Question 2The mean of the Binomial distribution $B\left(4, \frac{1}{3}\right)$ is equal to

(a) $\frac{3}{5}$

(b) $\frac{8}{3}$

(c) $\frac{3}{4}$

(d) $\frac{4}{3}$

Answer: d**Explanation:**

$$X \sim B(n, P) = B\left(4, \frac{1}{3}\right)$$

$$\text{We get } n = 4, P = \frac{1}{3}$$

$$\text{Mean} = np$$

$$= 4 \times \frac{1}{3} = \frac{4}{3}$$

Question 3If for a normal distribution $Q_1 = 54.52$ and $Q_3 = 78.86$, then the median of the distribution is

(a) 12.17

(b) 12.17

(c) 66.369

(d) None

Answer: c**Explanation:**

$$Q_1 = 54.52 \text{ and } Q_3 = 78.86$$

We know that

$$Q_1 = \mu - 0.675\sigma = 54.52 \quad \text{_____ (1)}$$

$$Q_3 = \mu + 0.675\sigma = 78.86 \quad \text{_____ (2)}$$

On adding

$$2\mu = 133.38$$

$$\mu = \frac{133.38}{2}$$

$$\mu = 66.69$$

In normal distribution Mean, Median and mode are equal.

So, Median = Mean = 66.369

Question 4

What is the mean of X having the following density function?

$$f(x) = \frac{1}{\sqrt[4]{2x}} e^{-\left(\frac{x-10}{32}\right)^2} \text{ for } -\infty < x < \infty$$

- (a) 10 (b) 4
(c) 40 (d) None

Answer: a

Explanation:

Given Normal distribution

$$f(x) = \frac{1}{\sqrt[4]{2x}} e^{-\left(\frac{x-10}{32}\right)^2} \text{ for } -\infty < x < \infty$$

On comparing from

$$f(x) = \frac{1}{\sqrt[4]{2x}} e^{-\left(\frac{x-10}{32}\right)^2} \text{ for } -\infty < x < \infty$$

on comparing from

$$f(x) = \frac{1}{\sigma\sqrt{2\pi}} e^{-\frac{x-\mu}{2(\sigma)^2}}$$

we get

$$\text{Mean } (\mu) = 10$$

$$\sigma = 4$$

Question 5

The probability that a student is not a Swimmer is $\frac{1}{5}$, then the probability that out of five student four are swimmer is

- (a) $\left(\frac{4}{5}\right)^4 \left(\frac{1}{5}\right)$ (b) $5 {}_5C_1 \left(\frac{1}{5}\right)^4 \left(\frac{4}{5}\right)$
(c) $5 {}_5C_4 \left(\frac{4}{5}\right)^1 \left(\frac{1}{5}\right)^4$ (d) None

Answer: c

Explanation:

Given:

$$\text{Probability that a student is not a swimmer } (q) = \frac{1}{5}$$

$$\text{Probability that a student is a swimmer } (P) = 1 - q = 1 - \frac{1}{5} = \frac{4}{5}$$

Total No. of student (n) = 5

P (Exactly 4 student are swimmer)

$$= P (x=4)$$

$$5 {}_5C_4 \left(\frac{4}{5}\right)^1 \left(\frac{1}{5}\right)^4 \{ \because P (x = n) = n {}_n C_x \cdot q^x \cdot p^{n-x} \}$$

MAY 2019

Question 1

If mean and variance are 5 and 3 respectively then relation between p & q is

- (a) $p > q$ (b) $p < q$
 (c) $p = q$ (d) p is symmetric

Answer: b

Explanation:

If mean and variance are 5 and 3 respectively then relation between p & q is $p < q$

Question 2

If $Y \geq x$ then mathematical expectation is

- (a) $E(X) > E(Y)$ (b) $E(X) \leq E(Y)$
 (c) $E(x) = E(Y)$ (d) $E(X) \cdot E(Y) = 1$

Answer: b

Explanation:

$$E(X) \leq E(Y)$$

Question 3

4 coins were tossed 1600 times. What is the probability that all 4 coins do not turn head upward at a time?

- (a) $1600e^{-100}$ (b) $1000e^{-100}$
 (c) $100e^{-1600}$ (d) e^{-100}

Answer: d

Probability of Head = $1/2$

Probability of not head = $1 - 1/2 = 1/2$

probability that all 4 coins do not turn head upward at a time

= $1 - \text{Probability that 4 coins turn head upward at a time}$

$$= 1 - {}^4C_4(1/2)^4(1/2)^0$$

$$= 1 - 1/16$$

$$= 15/16$$

$15/16$ is the probability that all 4 coins do not turn head upward at a time

$$1600 * 15/16 = 1500$$

1500 times all 4 coins do not turn head upward at a time

Question 4

In _____ distribution, mean = variance:

- (a) Binomial (b) Poisson
 (c) Normal (d) None of these

Answer: b

Explanation:

Poisson; $np = npq$

$Np = \text{mean}$

Npq = variance

Question 5

In a Binomial Distribution, if $p = q$, then $P(X = x)$ is given by

- (a) ${}^n C_x (0.5)^n$ (b) ${}^n C_n (0.5)^n$
 (c) ${}^n C_x p^{(n-x)}$ (d) ${}^n C_n p^{(n-x)}$

Answer: a

Explanation:

If $p = q$, then $p = 0.5$

Substituting in $P(x) = {}^n C_x p^x q^{(n-x)}$ we get ${}^n C_n (0.5)^n$.

NOV 2019

Question 1

Area under $U = 3\sigma$

- (a) 99.73% (b) 99%
 (c) 100% (d) 99.37%

Answer: a

Explanation:

(a) We know that 99.37 percent of the values of a normal variable lies between $(u - 3\sigma)$ and $(u + 3\sigma)$.

Thus probability that a value of x lies. Outside the limit is as low as

$(100 - 99.73) = 0.27\%$

Question 2

For a Poisson distribution:

- (a) mean and SD are equal (b) mean and variance are equal
 (c) SD and Variance (d) Both a and b

Answer: b

Explanation:

(b) Poisson distribution is theoretical discrete probability distribution which can describe many processes

Mean is given by m i.e. $U = m$

Variance is also given by m i.e. $\sigma^2 = m$

So in Poisson distribution mean and variance are equal.

Question 3

Find mode when $n = 15$ and $p = \frac{1}{4}$ in binomial distribution?

- (a) 4 (b) 4 and 3
 (c) 4.2 (d) 3.7

Answer: b

Explanation:

(b) In binomial distribution,

$$m = (n + 1) p$$

$$m = (15 + 1) \times \frac{1}{4}$$

$$m = 4$$

Since 4 is a integer so there will 2 modes

4 and (4 - 1)

Mode = 4 and 3

Question 4**In Poisson distribution, if $P(x = 2) = \frac{1}{2} P(x = 3)$ find m ?**

(a) 3

(b) $\frac{1}{6}$

(c) 6

(d) $\frac{1}{3}$ **Answer: c****Explanation:**(c) In Poisson distribution $P(x = x) = \frac{e^{-m} \cdot m^x}{x!}$ Here $P(x = 2) = \frac{1}{2} P(x = 3)$

$$\frac{e^{-m} \cdot m^2}{2!} = \frac{1}{2} \times \frac{e^{-m} \cdot m^3}{3!}$$

$$\frac{e^{-m} \cdot m^2}{2!} = \frac{1}{2} \times \frac{e^{-m} \cdot m^3}{3!}$$

$$\frac{m^2}{2} = \frac{1}{2} \times \frac{m^3}{6}$$

$$m^2 = \frac{2}{12} = \frac{1}{6} m^3$$

$$m^{-1} \frac{1}{6}$$

$$\frac{1}{m} = \frac{1}{6} = m = 6$$

Question 5**In a binomial distribution $B(n, p)$** **$n = 4$ $P(x = 2) = 3 \times P(x = 3)$ find P** (a) $\frac{1}{3}$ (b) $\frac{2}{3}$ (c) $\frac{6}{4}$ (d) $\frac{4}{3}$ **Answer: a****Explanation:**We know $P(x = r) = {}^n C_r (p)^r (q)^{n-r}$

Here $p(x = 2) = 3 P(x = 3)$
 ${}^4C_2 (p)^2 (q)^{4-2} = 3 \times {}^4C_3 (p)^3 (q)^1$
 $\frac{4!}{(4-2)1 \times 2!} (p)^2 (1-p)^2 = 3 \times \frac{4!}{(4-3)1 \times 3!} \times (p)^3 (1-p)$

Since ${}^n C_r = \frac{n!}{(n-r)!1 \times r!}$

$6 \times (1-p) = 3 \times 4 p$

$6 - 6p = 12 p$

$18 p = 6$

$P = \frac{1}{3}$

$q = 1 - \frac{1}{3} = \frac{2}{3}$

What is the SD and mean

X if $f(x) = \frac{\sqrt{2}}{\sqrt{\pi}} \cdot e^{-\frac{x-\mu}{2\sigma^2}}$ _____ (1)

Here, $\sqrt{\frac{2}{\pi}} \cdot e^{-2(x-3)^2}$

$= \sqrt{\frac{2}{\pi}} \cdot e^{-\left(\frac{1-3}{\frac{1}{2}}\right)^2}$

On comparing with equation ----- (1)

$2\sigma^2 = \frac{1}{2} u = 3$

$\sigma^2 = \frac{1}{4}$

$\sigma = \frac{1}{2}$

So SD = $\frac{1}{2}$, mean = 3

DEC 2020

Question1

Which of the following is uni-parametric distribution?

- | | |
|--------------|---------------------|
| (a) Normal | (b) Poisson |
| (c) Binomial | (d) Hyper geometric |

Answer: b

Explanation:

Poisson distribution is uniparametric distribution. the parameter is m which is mean=np

Question2

If the probability of success in a binomial distribution is less than one - half, then the binomial distribution _____

- | | |
|-----------------------|------------------------|
| (a) Is skewed to left | (b) Is skewed to right |
|-----------------------|------------------------|

(c) Has two modes

(d) Has median at a point $> \text{mean} + \frac{1}{2}$

Answer: b

Explanation:

Is skewed to right

Question3

If we change the parameter(s) of a _____ distribution the Sharpe of probability curve does not change.

(a) Binomial

(b) Normal

(c) Poisson

(d) Non – Gaussian

Answer: b

Explanation:

If we change the parameter(s) of abnormal distribution the Sharpe of probability curve does not change.

Question4

Which one of the following has Poisson distribution?

(a) The number of days to get a complete cure

(b) The number of defects per meter on

Long roll of coated polythene sheet.

(c) The errors obtained in repeated Measuring of The length of a rod.

(d) The number of claims rejected by an

Insurance agency.

Answer: b

Explanation:

The number of defects per meter on long roll of coated polythene sheet.

Question5

For a Poisson distributed variable X, we have $P(X = 7) = 8 \cdot P(X = 9)$, the mean of the distribution is

(a) 4

(b) 3

(c) 7

(d) 9

Answer: b

Explanation:

$$P(X = n) = \frac{\lambda^n e^{-\lambda}}{n!} = \frac{8 \cdot \lambda^9 e^{-\lambda}}{9!} \frac{9!}{7! \times 8} \lambda^2$$

$$\lambda = 3$$

Question6

The quartile deviation of a normal distribution with mean 10 and standard deviation 4 is _____

- (a) 54.24 (b) 23.20
(c) 0.275 (d) 2.70

Answer: d

Explanation:

In normal distribution, quartile deviation is related to standard deviation as

$$Q.D. = 0.675 \sigma$$

$$Q.D. = 0.675 \times 4$$

$$Q.D. = 2.70$$

Therefore, quartile deviation is 2.70.

Question7

If the parameter of poisson distribution is m and (mean + S.D.= 25 6 then find m.

- (a) $\frac{3}{25}$ (b) $\frac{1}{25}$
(c) $\frac{4}{25}$ (d) $\frac{3}{5}$

Answer: b

Explanation:

Let, Mean of the Poisson distribute = μ

For a Poisson distribution,

$$\text{Standard Deviation (SD)} = \sqrt{\text{mean}}$$

$$\Rightarrow SD = \sqrt{\mu}$$

$$\text{Mean} + SD = \frac{6}{25} \text{ (Given)}$$

$$\mu + \sqrt{\mu} = \frac{6}{25}$$

$$\Rightarrow \sqrt{\mu} = \frac{6}{25} - \mu$$

On squaring both sides,

$$(\sqrt{\mu})^2 \left(\frac{6}{25} - \mu \right)^2$$

$$\mu = \mu^2 - \frac{12}{25} \mu + \frac{36}{625}$$

$$\Rightarrow 0 = \mu^2 - \frac{37}{25} \mu + \frac{36}{625}$$

$$\Rightarrow 0 = \left(\mu - \frac{1}{25} \right) \left(\mu - \frac{36}{25} \right)$$

$$\Rightarrow \mu = \frac{1}{25}, \frac{36}{25}$$

Maximum likelihood estimate of a sample from Poisson Distribution is the sample mean which is equal to parameter of Poisson's Distribution.

$$\Rightarrow \mu = m = \frac{1}{25}$$

\therefore The correct option is B $\frac{1}{25}$

JAN 2021**Question1**

If X is a poisson variable, and $P(X = 1) = P(X = 2)$, then $P(X = 4)$ is

(a) $\frac{2}{3}e^2$

(b) $\frac{2}{3}e^4$

(c) $\frac{3}{2}e^2$

(d) $\frac{3}{2}e^4$

Answer: a

Explanation:

$$P(x; \mu) = \frac{e^{-\mu} \mu^x}{x!}$$

$$P(X = 1) = P(X = 2)$$

$$\frac{e^{-\mu} \mu^1}{1!} = \frac{e^{-\mu} \mu^2}{2!}$$

$$\mu = 2$$

$$P(X = 4) = \frac{e^{-\mu} \mu^x}{4!} = \frac{2}{3}e^2$$

Question2

Which one of the following is an uniparametric distribution?

(a) Poisson

(b) Normal

(c) Binomial

(d) Hyper geometric

Answer: a

Explanation:

Poisson distribution is uniparametric distribution. The parameter is m which is mean= np . Bcz it has λ as a parameter.

Question3

For a normal distribution, the value of third moment about mean is

(a) 0

(b) 1

(c) 2

(d) 3

Answer: a

Explanation:

$E[(X-\mu)^3]=0$ since $X-\mu$ is normally distributed with mean zero, then expand out the cube. If the distribution of a random variable X is symmetric about 0, meaning $\Pr(X>x)=\Pr(X<-x)$ for every $x>0$, then its third moment, if it exists at all, must be 0, as must all of its odd-numbered moments.

JULY 2021**Question1**

The value of K for the probability density function of a variate X is equal to

X	0	1	2	3	4	5	6
P (X)	5K	3K	4K	6K	7K	9K	11K

- (a) 39 (b) 1/40
(c) 1/49 (d) 1/45

Answer: Options (c)

Explanation

Note: - Sum of all probabilities = 1

Therefore, $5k + 3k + 4k + 6k + 7k + 9k + 11k = 1$

$\therefore k = 1/49$

Question 2

If is a Position variate such that $P(x = 1) = 0.7$, $P(x = 2) = 0.3$, then $P(x = 0) =$

- (a) $e^{6/7}$ (b) $e^{-6/7}$
(c) $e^{-2/3}$ (d) $e^{-1/3}$

Answer: Options (b)

Question 3

If X is a binomial variate with $p = 1/3$ for, the experiment of 90 trials, then the standard deviation is equal to

- (a) $-\sqrt{5}$ (b) $\sqrt{5}$
(c) $2\sqrt{5}$ (d) $\sqrt{15}$

Answer: Options (c)

Question 4

For a certain type of mobiles, the length of time between charges of the battery is normally distributed with a mean of 50 hours and a standard deviation of 15 hours. A person owns one of these mobiles and want to know the probability the Length of time will be between 50 and 70 hours is (Given $\phi(1.33) = 0.9082$, $\phi(0) = 0.5$)

- (a) -0.4082 (b) 0.5
(c) 0.4082 (d) -0.5

Answer: Options (c)

Explanation:

Given,

$\mu = 50$ (mean)

$\sigma = 15$ (standard/deviation)

find the probability for $50 < x < 70$

Converting the problem in standard form

$$Z = \frac{(x - \mu)}{\sigma}$$

for $x = 50$,

$Z=0$

For $x=70$,

$Z = (70-50)/15=1.33$

For finding the probability for $50 < x < 70$

In the standard form $0 < z < 1.33$

using Z-table, the area is equal to 0.4082

DEC 2021

Question 1

The average number of advertisements per page appearing in a newspaper is 3.

What is the probability that in a particular page zero

- | | |
|--------------|--------------|
| (a) e^{-3} | (b) e^{-1} |
| (c) e^3 | (d) e^0 |

Answer: a

Explanation:

Given $m = 3$; $x = 0$

As per Poisson Distribution, $P(x) = \frac{e^{-m} m^x}{x!}$

$$P(x = 0) = \frac{e^{-3} m^0}{0!} = e^{-3}$$

Question 2

Four unbiased coins are tossed simultaneously. The expected number of heads is:

- | | |
|-------|-------|
| (a) 1 | (b) 2 |
| (c) 3 | (d) 4 |

Answer: b

Explanation:

Since four coins are being tossed, we have $n = 4$.

Probability of getting a "heads" in each trial (p) = $\frac{1}{2}$

Expected number of Heads = $np = 4 \times \frac{1}{2} = 2$.

Question 3

If, for a Poisson distributed random variable X, the probability for X taking value 2 is 3 times the probability for X taking value 4, then the variance of X is

- | | |
|-------|-------|
| (a) 4 | (b) 3 |
| (c) 2 | (d) 5 |

Answer: c

Explanation:

Poisson Distribution, $P(x) = \frac{e^{-m} m^x}{x!}$

$$P(x = 2) = 3P(x = 4)$$

$$\frac{e^{-m}m^2}{2!} = 3 \times \frac{e^{-m}m^4}{4!}$$

$$\frac{1}{2} = \frac{3m^2}{24}$$

$$\frac{6m^2}{24} = 1$$

$$m^2 = \frac{24}{6} = 4$$

$$m = \sqrt{4} = 2$$

Question 4

Let X be normal distribution with mean 2.5 and variance 1. If $P[a < X < 2.5] = 0.4772$ and that the cumulative normal probability value at 2 is 0.9772, then a = ?

- (a) 0.5 (b) 3
(c) -3.5 (d) -4.5

Answer: a**Explanation:**

We know that for a standard normal deviate, $z = \frac{x - \mu}{\sigma}$

Therefore, for $x = 2.5$, $z = \frac{2.5 - 2.5}{1} = 0$

Therefore, we need the area of 0.4772 from the mean till a certain point on the left-hand side.

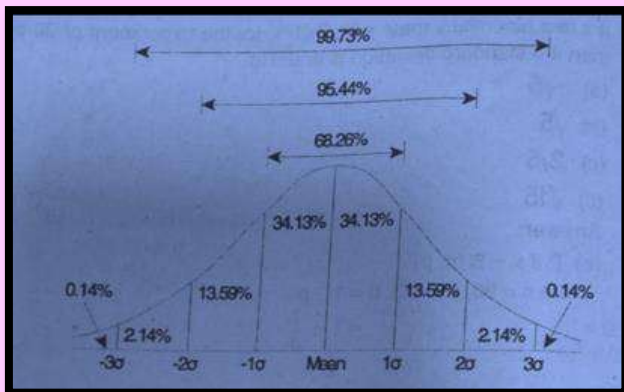

From the graph above, we can see that the area from mean till -2σ is 47.72%, i.e., 0.4772.

Thus, the corresponding z for the value of $x = a$ should be -2.

Therefore, $-2 = \frac{a - 2.5}{1}$

$$= -2 = a - 2.5$$

$$= 2.5 - 2 = a$$

$$= a = 0.5$$

Question 5

The manufacturer of a certain electronic component is certain that 2% of his

product is defective. He sells the components in boxes of 120 and guarantees that not more than 2% in any box will be defective. Find the probability that a box, selected at random would fail to meet the guarantee? (Given that $e^{-2.4} = 0.0907$)

- (a) 0.49 (b) 0.39
(c) 0.37 (d) 0.43

Answer: d

Explanation:

Here, $n = 120$; $p = 2/100 = 0.02$

$m = np = 120 \times 0.02 = 2.40$

As per Poisson Distribution, $P(x) = \frac{e^{-m} m^x}{x!}$

A box, selected at random would fail to meet the guarantee if more than 2.40 components turn out to be defective.

$P(x > 2.40) = 1 - P(x \leq 2.40)$

$P(x > 2.40) = 1 - [P(x = 0) + P(x = 1) + P(x = 2)]$

$P(x > 2.40) = 1 - \left[\frac{e^{-2.40} \cdot (2.40)^0}{0!} + \frac{e^{-2.40} \cdot (2.40)^1}{1!} + \frac{e^{-2.40} \cdot (2.40)^2}{2!} \right]$

$P(x > 2.40) = 1 - \left[\frac{0.0907 \times 1}{1} + \frac{0.0907 \times 2.40}{1} + \frac{0.0907 \cdot (2.40)^2}{2} \right]$

$P(x > 2.40) = 0.43$

Question 6

A renowned hospital usually admits 200 patients everyday. One percent patients, on an average, require special room facilities. On one particular morning, it was found that only one special room is available. What is the probability that more than 3 patients would require special room facilities?

- (a) 0.1428 (b) 0.1732
(c) 0.2235 (d) 0.3450

Answer: a

Explanation:

Here $n = 200$; $p = 1/100$

Therefore, $m = np = 200 \times 1/100 = 2$

As per Poisson Distribution, $P(x) = \frac{e^{-m} m^x}{x!}$

$P(x > 3) = 1 - P(x \leq 3)$

$P(x > 3) = 1 - [P(x = 0) + P(x = 1) + P(x = 2) + P(x = 3)]$

$P(x > 3) = 1 - \left[\frac{e^{-2} \times 2^0}{0!} + \frac{e^{-2} \times 2^1}{1!} + \frac{e^{-2} \times 2^2}{2!} + \frac{e^{-2} \times 2^3}{3!} \right]$

$P(x > 3) = 1 - \left[\frac{271828^{-2} \times 2^0}{0!} + \frac{271828^{-2} \times 2^1}{1!} + \frac{271828^{-2} \times 2^2}{2!} + \frac{271828^{-2} \times 2^3}{3!} \right]$

$P(x > 3) = 1 - \left[\frac{1}{271828^2} + \frac{2}{271828^2} + \frac{4}{2 \times 271828^2} + \frac{8}{3 \times 271828^2} \right]$

$P(x > 3) = 1 - \left[\frac{1}{(2.71828)^2} \left\{ 1 + 2 + \frac{4}{2} + \frac{8}{3} \right\} \right]$

For a binomial distribution, there may be

- (a) One mode (b) Multi mode
(c) Two mode (d) No mode

Answer:

Explanation:

a For a binomial distribution, there may be multimode.

DEC 2022

Question 1

Skewness of Normal Distribution is

- a) Negative (b) Positive
c) zero (d) Undefined

Answer: Options (c)

Explanation:

The skewness for a normal distribution is zero, and any symmetric data should have a skewness near **zero**. Negative values for the skewness indicate data that are skewed left and positive values for the skewness indicate data that are skewed right. By skewed left, we mean that the left tail is long relative to the right tail. Similarly, skewed right means that the right tail is long relative to the left tail. If the data are multi-modal, then this may affect the sign of the skewness.

Question 2

If a Poission distribution in such that $P(X=2)=P(X=3)$ than the variance of the distribution is

- a) $\sqrt{3}$ (b) 3
c) 6 (d) 9

Answer: Options (b)

Explanation:

Mean =? Variance =?

$$P(X = x) = \frac{e^{-\lambda} \lambda^x}{x!}$$

$$P(x = 2) = P(X = 3)$$

$$X = 2$$

$$\frac{e^{-\lambda} \lambda^2}{2!} = \frac{e^{-\lambda} \lambda^3}{3!}$$

$$\frac{1}{2} = \frac{\lambda}{3 \times 2}$$

$$\lambda = 3$$

CHAPTER - 17 CORRELATION AND REGRESSION

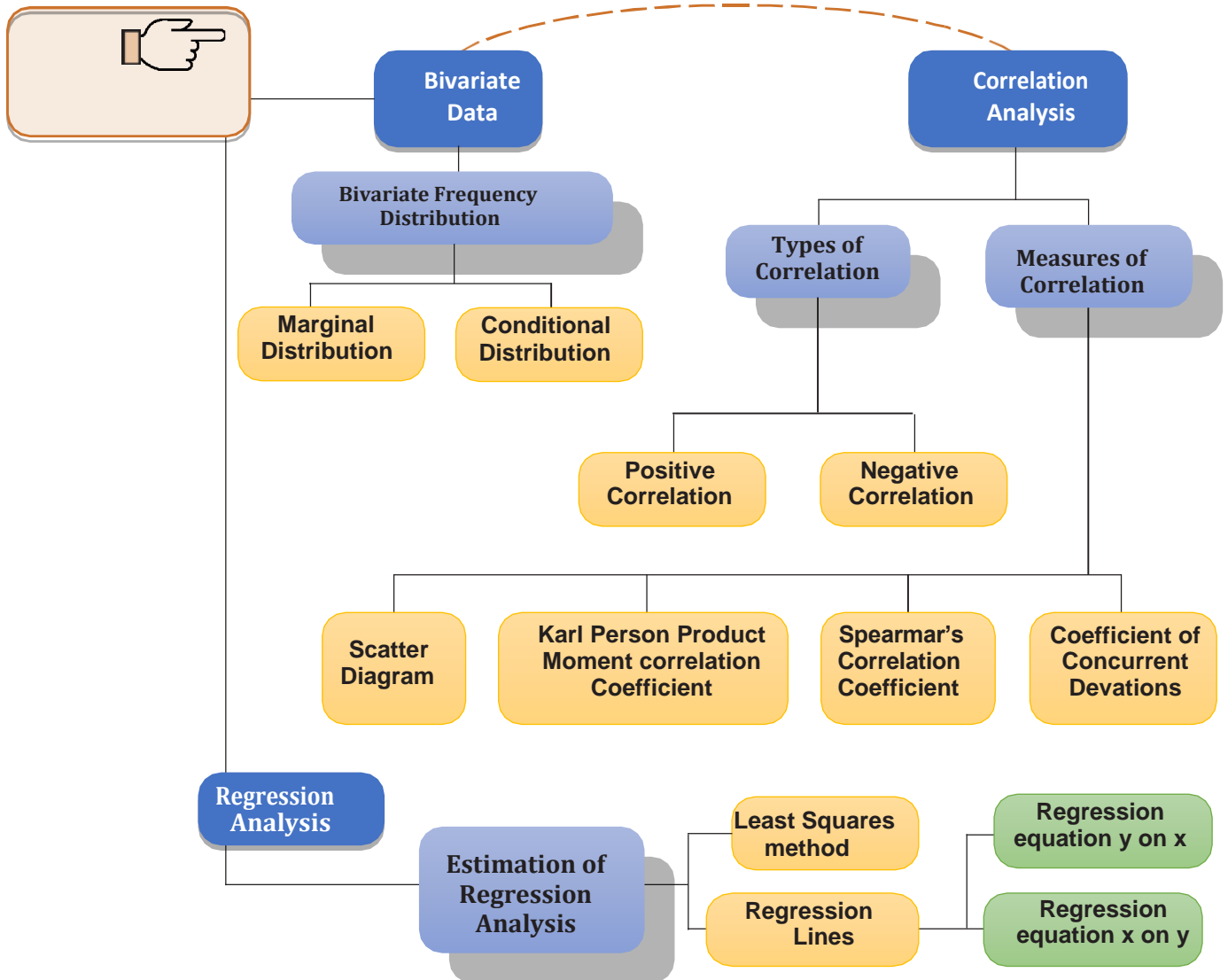

CORRELATION

The change in one variable is reciprocated by a corresponding change in the other variable either directly or inversely, then the two variables are known to be associated or correlated

TYPES OF CORRELATION

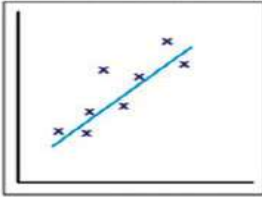
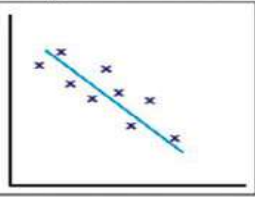
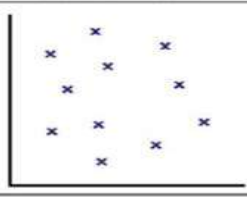
Positive correlation	Negative correlation	No correlation
		
The points lie close to a straight line, which has a positive gradient.	The points lie close to a straight line, which has a negative gradient.	There is no pattern to the points.
This shows that as one variable increases the other increases .	This shows that as one variable increases , the other decreases .	This shows that there is no connection between the two variables.

MEASURES OF CORRELATION

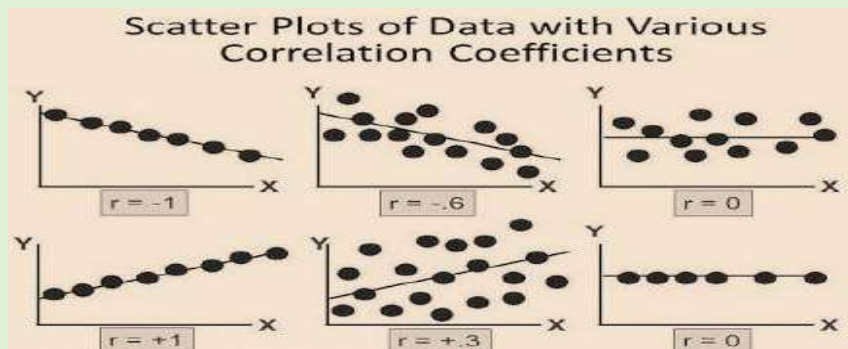

Rank Correlation

□ The formula of Spearman's Rank correlation coefficient, is given as:

$$r_s = 1 - \frac{6 \sum d_i^2}{n(n^2 - 1)}$$

r_s : is the coefficient of rank correlation.

d_i : is the difference in rank between paired values of X and Y . it can be calculated as (rank of X_i - rank of Y_i).

n : is a sample size or the number of pairs values X and Y in the selected sample.

Correlation Coefficient

Correlation coefficient

- A measure of the strength and the direction of a linear relationship between two variables.
- The symbol r represents the sample correlation coefficient.
- A formula for r is

$$r = \frac{n \sum xy - (\sum x)(\sum y)}{\sqrt{n \sum x^2 - (\sum x)^2} \sqrt{n \sum y^2 - (\sum y)^2}} \quad n \text{ is the number of data pairs}$$

- The population correlation coefficient is represented by ρ (rho).

Pearson's Correlation Coeff.

Pearson's correlation coefficient between two variables is defined as the covariance of the two variables divided by the product of their standard deviations:

$$\rho_{X,Y} = \frac{\text{cov}(X,Y)}{\sigma_X \sigma_Y} = \frac{E[(X - \mu_X)(Y - \mu_Y)]}{\sigma_X \sigma_Y},$$

The above formula defines the *population* correlation coefficient, commonly represented by the Greek letter ρ (rho). Substituting estimates of the covariances and variances based on a sample gives the *sample correlation coefficient*, commonly denoted r :

$$r = \frac{\sum_{i=1}^n (X_i - \bar{X})(Y_i - \bar{Y})}{\sqrt{\sum_{i=1}^n (X_i - \bar{X})^2} \sqrt{\sum_{i=1}^n (Y_i - \bar{Y})^2}}$$

$$r_{xy} = \frac{\sum x_i y_i - n \bar{x} \bar{y}}{n s_x s_y} = \frac{n \sum x_i y_i - \sum x_i \sum y_i}{\sqrt{n \sum x_i^2 - (\sum x_i)^2} \sqrt{n \sum y_i^2 - (\sum y_i)^2}}$$

POINT TO SIGNIFY

The 'coefficient of non-determination' is given by $(1-r^2)$ and can be interpreted as the ratio of unexplained variance to the total variance.

The two lines of regression coincide i.e. become identical when $r = -1$ or 1 or in other words, there is a perfect negative or positive correlation between the two variables under discussion. If $r = 0$ Regression lines are perpendicular to each other

The two lines of regression intersect at the point, where x and y are the variables under consideration

Thereaggressioncoefficientsremainunchangedduetoashift oforiginbutchangeduetoa shift of scale.



Question 1

The table below show the height, x , in inches and the pulse rate y , per minute for 9 people find the correlation coefficient and interpret your result.

X	68	72	65	70	62	75	78	64	68
Y	90	85	88	100	105	98	70	65	72

- (a) 0.69
(c) 0.15

- (b) 0.56
(d) None

For more Info Visit - www.KITest.in

Answer: c**Explanation:**

You may use the fact that (double check this for practice)

$$\sum x = 622, \sum y = 773, \sum x^2 = \sum y^2 = 68.007, \sum xy = 53,336$$

Calculate the numerator

$$x^2 = 43206$$

$$y^2 = 68007$$

$$n\sum(xy) - (\sum x)(\sum y) = 9.53336 - 622.773 = -782$$

$$\sqrt{n \sum x^2 - (\sum x)^2} \sqrt{n \sum y^2 - (\sum y)^2}$$

$$= \sqrt{9.43206 - (622)^2} \cdot \sqrt{9.68007 - (773)^2}$$

$$= \sqrt{1970} \cdot \sqrt{14534} = 5350.89$$

$$\text{Now, divide to get } r = \frac{-782}{5350.89} = 0.15$$

Question 2

In the previous problem the researcher decides to use data only for adults age 21 to 60 to compute a correlation coefficient what value of r should he expect?

- (a) $r = 0$ (b) $r \neq 0$
 (c) $r < 0$ (d) $r > 0$

Answer: a**Explanation:**

$r = 0$. It is unexpected that mathematical ability and shoe size varies together

Question 3

The following data relate to the test scores obtained eight salesmen in an aptitude test and their daily sales in thousands of rupees:

	1	2	3	4	5	6	7	8
Scores	60	55	62	56	62	64	70	54
Sales	31	28	26	24	30	35	28	24

- (a) 48 (b) 56
 (c) 4.5 (d) 0.48

Answer: d**Explanation:**

As

$$b = \frac{24+35}{2} = 30$$

Scores (xi) (i)	Sales in 1000(yi) (2)	ui=xi-62 (3)	Vi = yi - 30 (4)	Ui vi (5)=(3)×(4)	(6) = (U i) ²	(7) (Vi) ²
60	31	-2	1	-2	4	1
55	28	-7	-2	14	49	4
62	26	0	4	0	0	16
56	24	-6	-6	36	36	36
62	30	0	0	0	0	0
64	35	2	5	10	4	25
70	28	8	-2	-16	64	4

54	24	-8	6	48	64	36
Total	_	-13	-14	90	221	122

Since correlation coefficient remain unchanged due to change of origin we have

Question 4

If $r = 0.7$; and $n = 64$ find out the probable error of the coefficient of correlation.

- (a) 0.043 (b) 0.43
(b) 0.747, 0.657 (d) 0.7

Answer: a

Explanation:

$$r = 0.7; n = 64$$

$$P.E. = 0.67745 \times \left[\frac{1-r^2}{\sqrt{n}} \right]$$

$$\text{Probable Error (P.E)} = 0.6745 \times \frac{1-(0.7)^2}{\sqrt{64}}$$

$$= (0.6745) \times (0.06375)$$

$$= 0.043$$

Question 5

Compute the probable error assuming the correlation coefficient of 0.8 from a sample of 25 pairs of item

- (a) 0.0486 (b) 0.0456
(c) 0.0567 (d) 0.0789

Answer : a

Explanation:

$$r = 0.8, n = 25$$

$$P.E. = 0.6745$$

$$\frac{1 - (0.8)^2}{\sqrt{25}}$$

$$= 0.6745 \times 0.07 = 0.0486$$

Question 6

Difference between Correlation and Causation

- (a) The variable mutually influence each other so that neither can be called the causes of other
(b) The correlated variables are influenced By one or more variables.
(c) Pure change correlation (d) All

Answer: d

Explanation:

The term correlation should not be misunderstood as causation if correlation exists between two variables it must not be assumed that a changed in one variable is the cause of a change in over variable.

Question 7

**For some bivarilate data the following result were obtained the two variable X and Y:
 $x = 53.2, y = 27.9$ $b_{vx} = -1.5$ $b_{xy} = -0.2$**

The most probable value of y when $x = 60$ is

- (a) 15.6 (b) 13.4
(c) 19.7 (d) 17.7

Answer: d**Explanation:****The regression equation of y of x is:**

$$y - y = by x (x-x)$$

$$= y - 27.9 = (-1.5) (x - 53.2)$$

$$\text{Or } y = 107.7 - 1.5x$$

When $x = 60$ then

$$y = 107.7 - 1.5 \times 60 = 17.7$$

Question 9**If the sum of square of the rank difference in mathematics and physics marks of 10 students is 22, then the coefficient of rank correlation is:**

(a) 0.267

(b) 0.867

(c) 0.92

(d) None

Answer: b**Explanation:**

Co. efficient of rank correlation

$$1 - \frac{6 \sum d^2}{n(n^2-1)}$$

$$1 - \frac{6 \times 22}{10(10^2-1)}$$

$$1 - \frac{6 \times 2}{10 \times 9}$$

$$\frac{13}{15} = 0.867 \text{ (Approx.)}$$

Question 10**The coefficient of correlation r between x and y when: Cov (x, y) = - 16.5, Var (x) = 2.89, Var (y) = 100 is:**

(a) -0.97

(b) 0.97

(c) 0.89

(d) - 0.89

Answer: a**Explanation:**

$$r = \frac{\text{Cov}(x,y)}{\sigma_x \sigma_y}$$

$$\text{Or } r = \frac{\text{Cov}(x,y)}{\sqrt{\text{vary}(x) \times \text{vary}(y)}}$$

$$= \frac{-16.5}{\sqrt{2.89 \times 100}}$$

$$= -0.97$$

Question11**Two random variable have the regression line $3x + 2y = 26$ and $6x + y = 31$. The coefficient of correlation between x and y is:**

(a) -0.25

(b) -0.5

(c) 0.5

(d) 0.25

Answer: c**Explanation:**The regression lines $3x + 2y = 26$ and $6x + y = 31$ are givenLet first equation be y on x and second be x only respectively therefore, $3x + 2y = 26$

$$= \left(\frac{-3}{2}\right)x + 26$$

$$\begin{aligned} \therefore b_{yx} &= -3/2 \\ \text{and } 6x + y &= 31 \\ &= x = \left(\frac{-1}{6}\right)x + \left(\frac{31}{6}\right) \\ b_{yx} &= -1/6 \text{ Now} \\ r^2 &= b_{yx} \cdot b_{xy} \\ &= \left(\frac{-3}{2}\right) \times \left(\frac{-1}{6}\right) \\ &= 0.25 \\ r &= 0.5 \end{aligned}$$

Hence, our assumption hold true hold and $r = 0.5$ (- 1 r 1)

Note r is negative because b_{yx} and $b_{xy} = 0$

Question 12

The coefficient of correlation between X and Y is 0.6 U and V are two variable defined as $U = \frac{x-3}{2}, V = \frac{y-2}{3}$, then the coefficient of correlation between U and V is:

- (a) 0.6 (b) 0.8
(c) 0.4 (d) 1

Answer: a

Explanation:

Since correlation coefficient (Karl Pearson`s) is independence of both scale and origin therefore,

$$r(u,v) = r(x,y) = 0.6$$

it may be noted that if

$$\mu = ax + b \text{ and } V = cY + d \text{ then}$$

$r(u,v) = P(x,y)$ if a and c are of same signs

$P(x,y)$ if a and c are of opposite sing

Question 13

For the following data the coefficient of rank correlation is:

Rank in Botany	1	2	3	4	5
Rank in Chemistry	2	3	1	5	4

- (a) 0.93 (b) 0.4
(c) 0.6 (d) None

Answer: c

Explanation:

S No.	Rank in Botany(xi)	Rank in Chem (yi)	d = (xi) - (yi)	d ²
1	1	2	-1	1
2	2	3	-1	1
3	3	1	2	4
4	4	5	-1	1
5	5	4	1	1
Total			0	8

Hence coefficient of rank correction

$$1 - \frac{6 \times 8}{5(5^2 - 1)}$$

$$S = 1 - \frac{2}{5} = 0.6$$

Question 14

The following data is given on 450 students for marks in statistics and Economics at a certain examination

Mean marks in statistics = 40

Mean marks in economics = 48

S.D. of marks (statistics) = 12

Variance of marks (Economics) = 256

Sum of the products of deviation of

Marks from their respective mean = 42075

The average marks in economics of candidates who obtained 50 marks in statistics is:

- (a) 45 (b) 54
(c) 54.5 (d) 47.5

Answer: c

Explanation:

Let x = marks statistics

and y = marks in Economics

we know that

$$r_{xy} = \frac{\sum(dx \times dy)}{n \times \sigma_x \sigma_y}$$

Where $dx = x_1 - \bar{x}$ and $dy = y_1 - \bar{y}$

$$r_{xy} = \frac{(42075)}{450 \times 12 \times 16} = 0.49$$

Now regression equation of y on x

$$y - \bar{y} = \frac{r_{yx}(x - \bar{x})}{\sigma_x}$$

$$= y - 48 = x \frac{0.49 \times 16}{12} (x - 40)$$

$$\rightarrow Y = 0.65 + 22$$

When $x = 50$, then $y = 0.65 + 22$ When $x = 50$, then

$$y = 0.65x + 50 + 22 = 54.5$$

Question 15

For 10 pair of observation, number of concurrent deviation was found to be 4. what is the value of the coefficient deviation?

- (a) $\sqrt{0.2}$ (b) $-\sqrt{0.2}$
(c) $1/3$ (d) $-1/3$

Answer: d

Explanation:

Here $C = 4$, $N = 10$, So

$$n = N - 1 = 10 - 1 = 9$$

$$rc = \pm \sqrt{\frac{\pm(2c - n)}{n}}$$

$$rc = \pm \sqrt{\frac{\pm(2 \times 4 - 9)}{9}}$$

Here $(2c - n)$ is negative so negative sign is take at both the place so $rc = (-1)/3$

Question 16

Karl Pearson's formula:

$$(a) \frac{[N \sum XY - (\sum X)(\sum Y)]}{\sqrt{[N \sum X^2 - (\sum X)^2][N \sum Y^2 - (\sum Y)^2]}}$$

(c) Either a or b

Answer: b

Explanation:

$$r = \frac{n(\sum xy) - (\sum x)(\sum y)}{\sqrt{[n \sum x^2 - (\sum x)^2][n \sum y^2 - (\sum y)^2]}}$$

Where

N = number of pairs of scores

$\sum xy$ = sum of the products of paired scores

$\sum x$ = sum of x scores

$\sum y$ = sum of y scores

$\sum x^2$ = sum of squared x scores

$\sum y^2$ = sum of squared y scores

$$(b) r = \frac{n(\sum xy) - (\sum x)(\sum y)}{\sqrt{[n \sum x^2 - (\sum x)^2][n \sum y^2 - (\sum y)^2]}}$$

(d) None

Question 17

If the coefficient of correlation between x and Y variable is +0.90 then what will be coefficient of determination?

(a) 0.39

(b) 0.81

(c) 0.94

(d) None of these

Answer: b

Explanation:

If Coeff. of Correlation $r = 0.90$

Coeff. of Determination = r^2

$$= (0.90)^2$$

$$= 0.81$$

Question 18

The two lines of regression become identical when

(a) 0.4

(b) 0.6

(c) 0.36

(d) 0.64

Answer: c

Explanation:

If $r = 0.6$

Then Coeff. of determination = r^2

$$= (0.6)^2$$

$$= 0.36$$

Question 19

There two regression lines passing through

(a) Represent means

(b) Represent S. Ds

(c) (a) and (b)

(d) None of these

Answer: a

Explanation:

The two regressions lines passing through or (Intersect) at their means.

Question 20

The regression equation x and y is $3x + 2y = 100$ value of b_{xy}

(a) $-\frac{2}{3}$

(b) $-\frac{3}{2}$

(c) $\frac{2}{3}$

(d) $\frac{100}{2}$

Answer: a**Explanation:**

The regression equation of x & y is

$$3x + 2y = 100$$

$$3x + 2y - 100 = 0$$

$$b_{xy} = -\frac{\text{Coefficient of } y}{\text{coefficient of } x} = -\frac{2}{3}$$

Question 21**In beauty contest there were 10 competitors of these candidates assigned by two judge A and b the sum of squares of difference of rank is 44. The value of rank correlation is:**

(a) 0.70

(b) 0.73

(c) 0.80

(d) 0.60

Answer: b**Explanation:**Sum of square of difference of rank ($\sum d^2$) = 44 $r_{R}=?$

$$r_{R} = 1 - 6 \frac{\sum d^2}{n(n^2 - 1)}$$

$$1 - \frac{6 \times 44}{10(10^2 - 1)}$$

$$1 - \frac{6 \times 44}{10 \times 99}$$

$$= 1 - 0.267$$

$$= 0.733$$

So answer be 0.73

Question 22**If two regression lines are $x + y = 1$ and $x - y = 1$ then mean value of x and y will be:**

(a) 0 and 1

(b) 1 and 1

(c) 1 and 0

(d) None

Answer: c**Explanation:**

Given Regression line

$$x + y = 1$$

$$\underline{x - y = 1}$$

$$2x = 2$$

$$\Rightarrow x = \frac{2}{2} = 1$$

x = 1 in equation (1) we get

$$1 - y = 1$$

$$y = 0$$

Mean of x = $\bar{x} = 1$ Mean of y = $\bar{y} = 0$

Hence 1 and 0

Question 23**The coefficient of correlation between x and y is 0.6 If x and y value are multiplied by 1 then the coefficient will be**

(a) 0.6

(b) 1-0.6

(c) $1/0.6$ (d) -0.6 **Answer: a****Explanation:**

The coefficient of correlation between X and Y is 0.6 If x and y values are multiplied by 1 then coefficient remains unchanged then are coefficient of correlation will be 0.6

Question 24

The coefficient of correlation between the temperature of environment and power consumption is always:

(a) +ve

(b) - ve

(c) 0

(d) = 1

Answer: a**Explanation:**

The coefficient of correlation between the temperature of environment and power consumption is always positive.

Question 25

Out of the following the one which the regression coefficient is

(a) Change origin only

(b) Change of scale only

(c) Change of scale and origin both

(d) Neither a nor b

Answer: b**Explanation:**

By shifting the scale, coefficient of regression is changed.

Question 26

When the correlation coefficient r is equal to + 1 all the point in a scatter diagram would be

(a) On a straight line direct from upper left to lower right

(b) On a straight direction from lower left upper right

(c) On a straight line

(d) Both (a) and (b)

Answer: b**Explanation:**

When the correlation coefficient r is equal to + 1 all the point in a scatter diagram on a straight line directed from lower left to upper right.

Question 27

In case of "Insurance companies" profit and the number of claim they have to pay there is -----correlation.

(a) +ve

(b) -ve

(c) No relation

(d) None

Answer: b**Explanation:**

In case of "Insurance companies" profit and the number of claim they have to pay there pay there is Negative correlation:

Question 28

If the correlation coefficient between two variables is zero then the lines of regression are

(a) Parallel

(b) Perpendicular

(c) Coincide (d) None

Answer: b

Explanation:

If the correlation coefficient between two variables is zero then the lines of regression are perpendicular

Question 29

Their competitors in a contest are ranked by two judges in the order 1,2,3 and 2,3,1 respective Calculate the spearman`s rank correlation coefficient.

(a) -0.5 (b) -0.8
(c) 0.8 (d) 0.5

Answer: a

Explanation:

Rank by 1 st judge R ₁	Rank by 2 nd Judge R ₂	Diff D= R ₁ – R ₂	D ²
1	2	-1	1
2	3	-1	1
3	1	+2	4
			$\Sigma d^2 = 6$

Here n = 3

$$\begin{aligned} \text{Spearman`s Rank Correlation Coefficient} &= 1 - 6 \frac{\Sigma d^2}{n(n^2 - 1)} \\ &= 1 - \frac{6 \times 6}{3(3^2 - 1)} \\ &= -0.5 \end{aligned}$$

Question 30

The strength (degree) of the correlation between a set of independent variables X and dependent variable Y is measured by

(a) Coefficient of Correlation (b) Standard error of estimate
(c) Coefficient Determination (d) All of these

Answer: d

Explanation:

The strength (degree) of the correlation between a set of independent variables X and dependent variable Y is measured through

- Coefficient of Correlation
- Standard error of estimate
- Coefficient Determination

Question 31

The percent of told variation of the dependent variable Y explained by the set of independent variables X is measured by:

(a) Coefficient of Correlation (b) Standard error of estimate
(c) Coefficient Determination (d) Coefficient of skewness

Answer: c

Explanation:

The coefficient of determination (denoted by R²) is a key output of regression analysis an R² of 0 means that the dependent variable cannot be predicted from the independent variable An R² of 1 means the dependents variable can be predicted without error from the independent variable

Question 32

A coefficient of correlation is computed to be -0.95 means that

- (a) The relationship between two variables is weak
 (b) The relationship two variables is strong and positive
 (c) The relationship between two variables is strong and but negative
 (d) Correlation coefficient cannot have this value

Answer: c

Explanation:

A coefficient of correlation is compute to be -0.95 means that relationship between two variables is strong and but negative

Question 33

Let the coefficient of determination computed to be 0.39 in a problem involving one independent variable and one dependent variable this result means that

- (a) The relationship between two variables is negative
 (b) The correlation coefficient is 0.39 also
 (c) 39% of the total variation is explained by the independent variable
 (d) 39% of the total variation explained by the dependent variables

Answer: c

Explanation:

The coefficient of determination computed to be 0.39 in a problem involving one independent variable and one dependent variable. 39% of the total variation is explained by the independent variable.

Question 34

Relationship between correlation coefficient and coefficient of determination is that:

- (a) The coefficient of determination is the square of coefficient of correlation
 (b) The coefficient determination is the square root of the coefficient of correction
 (c) Both are unrelated
 (d) Both are equal

Answer: a

Explanation:

Coefficient of correlation is "R" value which given in the summary table in the regression output. R square is called coefficient of determination multiply R times R to get the R value. In other word coefficient of correlation R square or Coeff.of determination shows percentage variation and in y which is explained by all the x variable together higher the better it is always between 0 and 1. It can never be negative – since is a squared value.

It is easy to explain the R square in term of regression it is not so easy to explain the R in terms of regression.

Question 35

For a bivariate data two lines of regression are $40x - 18y = 214$ and $8x - 10y + 66 = 0$ then find the value of x and y

- (a) 17 and 13
 (b) 13 and 17
 (c) 15 and 17
 (d) None

Answer: b

Explanation:

Given: $40x - 18y = 214$

$$8x - 10y = -66$$

On solving (1) and (2) we get

$$x = 13 \text{ and } y = 17$$

$$\therefore x = 13 \text{ and } y = 17$$

Question 36

In multiple regression when the global test of significance is rejected we can conclude that:

- (a) All of the net sample regression coefficient are equal to zero
 (b) All of the sample regression coefficient are not equal to zero
 (c) At least one sample regression coefficient is not equal to zero
 (d) The regression equation intersects the y - axis at zero

Answer: c

Explanation:

In multiple regression when the global test of significance is rejected we can conclude that at least one simple regression coefficient is not equal to zero.

Question 37

Correlation Coefficient value lies between

- (a) - 1 and + 1
 (b) 0 and 1
 (c) -1 and 0
 (d) None

Answer: a

Explanation:

The strength of the linear association between two variables is qualified by the correlation coefficient the correlation coefficient always takes a value between -1 and 1 with 1 or -1 indicating perfect correlation (all point would lie along a straight line in this case)

Question 38

In correlation both variables are always

- (a) Random
 (b) Non Random
 (c) Same
 (d) None

Answer: a

Explanation:

Complete correlation between two variables is expressed by either + 1 or -1 when one variable increases the correlation is positive when on decrease as the order increases it is negative complete absence of correlation is represented by 0.

Question 39

The table below shows the number of absence x, in a calculus course and the final exam grade y for 7 student find the correlation coefficient.

x	1	0	2	6	4	3	3
y	95	90	90	55	70	80	85

- (a) 0.38
 (b) -0.38
 (c) 0.62
 (d) -0.93

Answer: d

Explanation:

You may use the facts that (double check this for practice)

$$\sum x = 19, \sum y = 565, \sum x^2 = 75, \sum y^2 = 46,775, \sum xy = 1,380$$

For more Info Visit - www.KITest.in

Calculate the numerator:

$$n \sum(xy) - (\sum x)(\sum y) = 7.1380 - 19 \times 565 = - 1075$$

Then the calculate the denominator;

$$\frac{\sqrt{[n(x^2) - (\sum x)^2]}\sqrt{[n(y^2) - (\sum y)^2]}}{(525 - 369) \cdot [327425 - 319225]}$$

Question 40

Two regression lines are parallel to each other if their slope is

- (a) Random (b) Non Random
(c) Same (d) None

Answer: c

Explanation:

When there is a reasonable amount of scatter we can draw to different regression lines depending upon which variable we consider to be the most accurate The first is a line of regression of y on x which can be used to estimate y given x the other is a line of regression of x on y used to estimate x given y Hence two regression lines are parallel to each other if their slope is same

Question 41

When regression line passes through the origin then

- (a) Regression coefficient is zero (b) Correlation is zero
(c) Intercept is zero (d) Association is zero

Answer: c

Explanation:

Prism linear regression analysis fits a straight line through your data and lets you force the line to go through the origin this is useful when you are sure that the line must begin at the origin (x = 0 and y = 0) Prism's nonlinear regression offers the equation line through origin.

Question 42

The table below shows the number of absence, x in a calculate course and the final exam grand, y for 7 student find the correlation coefficient.

x	1	0	2	6	4	3	3
y	85	80	70	55	90	90	95

- (a) 0.38 (b) 0.6
(c) -0.38 (d) 0.62

Answer: c

Explanation:

There are 7 ordered pairs (x,y) so n = 7 Calculate the needed sums:

X	Y	X ²	Y ²	xy
1	85	1	7225	85
0	80	0	6400	0
2	70	4	4900	140
6	55	36	3025	330
4	90	16	8100	360
3	90	9	8100	270
3	95	9	9025	285
X = 19	Y = 565	X ² = 75	Y ² = 46775	Xy = 1470

Calculation the numerator: $n \sum (xy) - (\sum x)(\sum y)$

$$= 7.1470 - 19.565$$

$$= -445$$

Then calculate the denominator:

$$\sqrt{n \sum x^2 - (\sum x)^2} \cdot \sqrt{n \sum y^2 - (\sum y)^2}$$

$$= \sqrt{7.75 - (19)^2} \cdot \sqrt{746775 - (565)^2}$$

$$= \sqrt{164} \cdot \sqrt{8200} = 1159.66$$

$$\text{Now, divide to get } r = \frac{-445}{1159.66} = -0.38$$

Question 43

If two variables oppose each other than the correlation will be

(a) Positive Correlation

(b) Negative Correlation

(c) Perfect Correlation

(d) None

Answer: b

Explanation:

A correlation of zero means there is no relationship between the two variables, when there is a negative correlation between two variables as the value of one variable increase the value of the other variable decrease and *vis- versa*

Question 44

The time x in years that an employee spent at a company and the employee's hourly pay, y for 5 employees are listed in the table below.

Calculate and interpret the correlation coefficient r. Include a plot of the data in your discussion

(a) 0.38

(b) -0.97

(c) 0.62

(d) None

Answer: d

Explanation:

X	Y	X ²	Y ²	xy
5	25	25	625	125
3	20	9	400	60
4	21	16	441	84
10	35	100	1225	350
15	38	225	1444	570
X = 37	Y=139	X ² 375	Y ² = 4135	XY = 1189

Hint Calculate the numerator:

$$n \sum (xy) - (\sum x)(\sum y) = 5.1189 - 37.139 = 802$$

Then calculate the denominator

$$= \sqrt{n \sum x^2 - (\sum x)^2} \cdot \sqrt{n \sum y^2 - (\sum y)^2}$$

$$= \sqrt{5 \times 375 - (37)^2} \cdot \sqrt{5.4135 - (37)^2}$$

$$= \sqrt{506} \cdot \sqrt{1354} = 827.72$$

$$\text{Now divide to get } r = \frac{802}{827.72} = 0.97$$

Question 45**Identify the true correlation**

- (a) -1 & 1
 (b) -1 & 0
 (c) 0 & 1
 (d) All are true

Answer: a**Explanation:**

This will always be a number between -1 and 1 (inclusive)

- If is close to 1 we say that the variables are positively correlated. This means there is likely a strong linear relationship between the two variables with a positive slope.
- If is close to -1 we say that the variable are negatively correlated this means there is likely a strong linear relationship between the two variable with a negative slope.
- If r is close to 0, we say that the variables are not correlation this means that variables may still be related some other way.

Question 46**A researcher carefully computes the correlation coefficient between two variables and gets $r = 1.23$ what does this value mean?**

- (a) $-1 \leq r \leq 1$
 (b) $-1 \geq r \geq 1$
 (c) Both
 (d) None

Answer: a**Explanation:**A error was made all correlation coefficient $-1 \leq r \leq 1$ **Question 47****If R^2 is zero that is no collinearly / Multicollinearity the variance inflation factor (VIF) will be**

- (a) 1
 (b) 2
 (c) 3
 (d) None

Answer: a**Explanation:**

$$VIF = \frac{1}{1-R^2}$$

Question 48**If the equation of regression line is $y = 5$, then what result will you take out from it?**

- (a) The line is parallel to x- axis
 (b) The line passes through (5,0)
 (c) The line passes through origin
 (d) The line passes through origin

Answer: a**Explanation:** $y = k$ for one value of y there are infinite value of x**Question 49****The method of least squares finds the best fit line that the error between observed and estimated point on the line**

- (a) Reduces to zero
 (b) Approaches to infinity
 (c) Minimize
 (d) Maximize

Answer: c**Explanation:**

The method of least squares finds the best fit line that minimize the error between observed and estimate points on the line.

Question50

A regression model may be:

- (a) Linear (b) Non - linear
(c) Both (a) and (b) (d) Neither (a) and (b)

Answer: a

Explanation:

In the regression it appears on the left side of the equal sign, while you can use regression to predict the dependent variable you always start with a set of known y value and use these to build (or to calibrate) the regression model may be linear and nonlinear both

PAST EXAMINATION QUESTION

MAY 2018

Question1

If the model points are a scatter diagram is evenly distributed then the correlation is:

- (a) 0 (b) -ve
(c) +ve (d) a or b

Answer: a

Explanation:

In the case of a positive correlation, the plotted points are distributed from lower left corner to upper right corner (in the general pattern of being evenly spread about a straight line with a positive slope), and in the case of a negative correlation, the plotted points are spread out about a straight line of a ...

Question2

If the plotted points in a scatter are evenly distributed, then the correlations zero.

The covariance between variable is

- (a) Strictly positive (b) Strictly negative
(c) Always zero. (d) Either positive or negative zero.

Answer: d

Explanation:

The Co- variance between two variables is either positive or negative or zero.

Question3

The coefficient of determination is defined by the formula.

$$(a) r^2 = \frac{1 - \text{unexplained variance}}{\text{Total variance}}$$

$$(b) r^2 = \frac{\text{explained variance}}{\text{Total variance}}$$

(c) Both (a) and (b)

(d) None

Answer: c

Explanation:

The coefficient of determination

$$r^2 = \frac{1 - \text{unexplained variance}}{\text{Total variance}}$$

$$r^2 = \frac{\text{explained variance}}{\text{Total variance}}$$

Question4

In the method of concurrent deviations only the directions of change (positive direction/ Negative direction) in the variable are taken into account for calculation of

(a) Coefficient of SD

(b) Coefficient of regression

(c) Coefficient of correlation

(d) None

Answer: c

Explanation:

The method of concurrent deviation only the direction of change (positive direction/ Negative direction) in the variables are taken into account for calculation of coefficient of correlation

Question5

Correlation coefficient is----of the units of measurement

(a) Dependent

(b) Independent

(c) Both

(d) None

Answer: b

Explanation:

Correlation coefficient is Independent of the units of measurement.

Question 6

In case speed of an automatic and the distance required to stop the car after applying correlation is

(a) +ve

(b) -ve

(c) 0

(d) None

Answer: a

Explanation:

In case speed of an automatic and the distance required to stop the car after applying correlation is positive

Question7

A relationship $r^2 = 1 - \frac{500}{300}$ is possible

- (a) True (b) False
(c) Both (d) None

Answer: a

Explanation:

$r^2 = 1 - \frac{500}{300}$ is possible

$r^2 = 1 - \frac{-200}{300}$ is not possible

So it is true

Question8

Rank correlation coefficient lies between

- (a) -1 to +1 (b) 0 to 1
(c) -1 to 0 (d) Both

Answer: a

Explanation:

Rank correlation coefficient lies between -1 to + 1 inclusive of both value.

NOV 2018

Question1

The two lines of regression intersect at the point

- (a) Mean (b) Mode
(c) Median (d) None

Answer: a

Explanation:

The two lines of regression intersect at the point is Mean.

Question2

If the two line of regression are $x + 2y - 5 = 0$ and 0 , then the regression line of y on x is:

- (a) $x + 2y - 5 = 0$ (b) $2x + 3y - 8 = 0$
(c) $x + 2y = 0$ (d) $2x + 3y = 0$

Answer: a

Explanation:

Given two regression line are

$x + 2y - 5 = 0$ and $2x + 3y - 8 = 0$

$b_{yx} = \frac{-\text{coeff. of } x}{\text{coeff of } y} = \frac{-1}{2}$ and $b_{xy} = \frac{-\text{coeff. of } y}{\text{coeff of } x} = \frac{-3}{2}$

Here, $b_{yx} \times b_{xy} \leq 1$ which is satisfied

So, 1st equation $x + 2y - 5 = 0$ is the regression equation y on x

Question3

If the two regression line lines are $3x=y$ and $8y = 6x$ the value of correlation coefficient is:

- (a) 0.5 (b) -0.5
(c) 0.75 (d) -0.80

Answer: a

Explanation:

Given

Regression line

$3x=y$ and $8y=6x$

$3x-y=0$ and $6x-8y=0$

$$b_{xy} = \frac{-\text{coeff.of } y}{\text{coeff of } x} \text{ and } b_{yx} = \frac{-\text{coeff.of } x}{\text{coeff of } y}$$

$$\frac{-(-1)}{3} = \frac{-6}{-8} = \frac{3}{4}$$

$$b_{xy} = \frac{1}{3} b_{yx} = 3/4$$

Coeff. of correlation is given by

$$r = \pm \sqrt{b_{yx} \times b_{xy}}$$

$$= \pm \sqrt{\frac{3}{4} \times \frac{1}{3}}$$

$$= \pm \frac{1}{2}$$

$$+1/2$$

$$= 0.5$$

Question4

The regression coefficient is independent of the change of

- (a) Scale (b) Origin
(c) Scale and Origin both (d) None

Answer: b

Explanation:

The regression coefficient is independent of the change of 'Origin'

Question5

If the correlation coefficient between the variable X and Y is 0.5, then the correlation between the variable $2x-4$ and $3-2y$

Answer:

$$2x-u-4=0 \quad \text{and} \quad 2y+v-3=0$$

$$b = \frac{-\text{coeff.of } u}{\text{coeff of } x} \text{ and } d = \frac{-\text{coeff.of } v}{\text{coeff of } y}$$

$$d = \frac{1}{2} \quad d = \frac{-1}{2}$$

Here, b and d both have different sign so $r_{uv} = -r_{xy}$

= -0.5

MAY 2019**Question1****Given that**

x	-3	-3/2	0	3/2	3
y	9	9/4	0	9/4	9

(a) Positive

(b) Zero

(c) Negative

(d) None

Answer: b**Explanation:**

x	y	X ²	Y ²	xy
-3	9	9	81	-27
-3/2	9/4	9/4	81/16	-27/8
0	0	0	0	0
3/2	9/4	9/4	81/16	27/8
3	9	9	81	27
0	$\frac{90}{4}$	$\frac{90}{4}$	$\frac{2754}{16}$	0
	$=\frac{45}{2}$	$=\frac{45}{2}$	$\frac{1377}{8}$	

Hence Answer 0

Question2**Given the following series:**

x	10	13	12	15	8	15
y	12	6	18	16	7	18

The rank correction coefficient r =

$$(a) 1 - \frac{6 \sum d^3 + \sum_{i=d}^2 \frac{m_2(m_2^3-1)}{12}}{m(n^2-1)}$$

$$(b) 1 - \frac{6 \left[\sum d^2 + \sum_{i=1}^3 \frac{m_2(m_1^2-1)}{12} \right]}{n(n^2-1)}$$

$$(c) 1 - \frac{6 \left[\sum d^2 + \sum_{i=1}^3 m_2(m_1^2-1) \right]}{n(n^2-1)}$$

(d) None

Answer: b**Explanation:**

$$1 - \frac{6 \left[\sum d^2 + \sum_{i=1}^3 \frac{m_2(m_1^2-1)}{12} \right]}{n(n^2-1)}$$

Question3**If the regression line of y on x is given by $y = x + 2$ and Karlperson's coefficient of**

correlation is 0.5 then $\frac{\sigma_y^2}{\sigma_x^2}$

- (a) 3 (b) 2
(c) 4 (d) None

Answer: c

Explanation:

y on x = $y = x + 2$

R = 0.5

$b_{yx} = r \times \frac{\sigma_y}{\sigma_x}$

$b_{yx} = \frac{2}{0.5}$

Question4

A.M. OF regression coefficient is:

- (a) Equal to r (b) Great than or equal to r
(c) Half of r (d) None of these

Answer: b

Explanation:

Regression coefficient is a statistical measure of the average functional relationship between two or more variable In regression analysis one variable is considered as dependent and other as independent, Thus it measure the degree of dependence of one variable on the order (s)

Question5

If the two regression lines are $x + y = 1$ and $x - y = 1$ then \bar{x} and \bar{y} are

- (a) 1,0 (b) 0,1
(c) 1,1 (d) None of these

Answer: d

Explanation:

Consider $x - y = 1$ as equation (1) as equation (2)

Now add both (1) and (2)

You get $2x = 2$ i.e. $x = 1$

Now put $x = 1$ in either of equation (1) or (2)

You get $y = 0$

Question6

Coefficient of correlation between X and Y is 0.6 if both X and Y are multiplied then resultant coefficient of correlation:

- (a) 0.6 (b) 1/0.6
(c) Both (d) None of these

Answer: a

Explanation:

Value of Correlation will -0.6 as if you multiply x & y by -1 then this will show negative sign and as per property b_{yx} , b_{xy} & r sign should be equal / same

NOV 2019

Question1

If two of regression are $x + 2y - 5 = 0$ and $2x + 3y - 8 = 0$ So $x + 2y - 5 = 0$ is

- (a) y on x
(b) x on y
(c) Both
(d) None

Answer: a

Explanation:

$$x + 2y - 5 = 0 \text{ - Eq 1} \quad 2x + 3y - 8 = 0 \text{ - Eq2}$$

Let Eq 1 be y on x from Eq2

$$b_{yx} = \frac{-\text{coefficient of } x}{\text{coefficient of } y} \quad b_{xy} = \frac{-\text{coefficient of } x}{\text{coefficient of } y}$$

$$b_{yx} = \left(\frac{-1}{2}\right) \times \left(\frac{-3}{2}\right) = \frac{3}{4}$$

So, $b_{yx} \times b_{xy} < 1$

So, $x + 2y - 5 = 0$ is y on x

and $2x + 3y - 8 = 0$ is x on y

Question2

Find the coefficient of regression.

$$2x + 3y = 2$$

$$4x + 3y = 4$$

- (a) 0.5
(b) -0.5
(c) 0.25
(d) -0.25

Answer: b

Explanation:

$$2x + 3y = 2 \text{ - Eq 1} \quad 4x + 3y = 4 \text{ - Eq 2}$$

Let Eq1 be y on x

From Eq1

$$b_{yx} = \frac{-\text{coefficient of } x}{\text{coefficient of } y} = \frac{-2}{3}$$

From Eq2

$$b_{xy} = \frac{-\text{coefficient of } x}{\text{coefficient of } y} = \frac{-3}{4}$$

So above assumption hold true.

$$r = \pm \sqrt{b_{yx} \times b_{xy}}$$

$$r = \pm \sqrt{\left(\frac{-2}{3}\right) \times \left(\frac{-3}{4}\right)}$$

$$r = \frac{-1}{2}$$

$$r = -0.5$$

Question3

What is the coefficient of correlation from the following data?

X:	1	2	3	4	5
Y:	5	4	3	2	6

- (a) 0
(c) -0.85
- (b) -0.75
(d) 0.82

Answer: a

Explanation:

X	Y	Xy
1	5	5
2	4	8
3	3	9
4	2	8
5	6	30
$\Sigma x = 15$	$\Sigma y = 20$	$\Sigma xy = 60$

$$\begin{aligned} \text{cov}(x,y) &= \frac{\Sigma xy}{n} - \bar{x} \cdot \bar{y} \\ &= \frac{60}{5} - \left(\frac{15}{5}\right) \times \left(\frac{20}{5}\right) \\ &= 12 - 12 \end{aligned}$$

$$\text{cov}(x,y) = 0$$

$$r = \frac{\text{cov}(x,y)}{\sigma_x \sigma_y}$$

$$r = 0$$

Question4

If the plotted points in a scatter diagram lie from upper left to lower right, then correlation is:

- (a) Positive
(c) Zero
- (b) Negative
(d) None of these

Answer: b

Explanation:

If the points in a scatter diagram lie from upper to left lower right then correlation is negative.

DEC 2020

Question 1

Which of the following is spurious correlation?

(a) Correlation between two variables having no causal relationship

(b) Negative Correlation

(c) Bad relation between two variables

(d) Very low correlation between two variables

Answer: a

Explanation:

Correlation between two variables having no causal relationship

Question 2

Scatter diagram does not help us to

(a) Find the type of correlation

(b) Identify whether variables correlated or not

(c) Determine the linear (or) non-linear correlation

(d) Find the numerical value of correlation coefficient

Answer: d

Explanation:

To Find the numerical value of correlation coefficient

Question 3

The Covariance between two variables is

(a) Strictly Positive

(b) Strictly Negative

(c) Always Zero

(d) Either positive (or) Negative (or) Zero

Answer: d

Explanation:

Covariance can be positive, zero, or negative. ... If X and Y are independent variables, then their covariance is 0: $\text{Cov}(X, Y) = E(XY) - \mu_X \mu_Y = E(X)E(Y) - \mu_X \mu_Y = 0$ The converse, however, is not always true. $\text{Cov}(X, Y)$ can be 0 for variables that are not independent. Hence, either positive (or) Negative (or) Zero

IAN 2021

Question 1

For the set of observations $\{(1, 2), (2, 5), (3, 7), (4, 8), (5, 10)\}$, the value of Karl-person's coefficient is approximately given by

(a) 0.755

(b) 0.655

(c) 0.525

(d) 0.985

Answer: d

Explanation:

x	y	xy	x ²	y ²
1	2	2	1	4

2	5	10	4	25
3	7	21	9	49
4	8	32	16	64
5	10	50	25	100
Total 15	32	115	55	242

$$5 \times 115 - 15 \times 32$$

$$\frac{\sqrt{5 \times 55 - (15)^2} \sqrt{5 \times 242 - (32)^2}}{95}$$

$$\frac{\sqrt{50} \sqrt{186}}{95}$$

$$\frac{7.07106 \times 13.638}{95} = 0.985105$$

Question 2

The coefficient of correlation between x and y is 0.5, the covariance is 16, and the standard deviation of x is 4. Then the standard deviation of y is

- (a) 4 (b) 8
(c) 16 (d) 64

Answer: b

Explanation:

$$r_{xy} = \frac{\text{cov}(x, y)}{\sqrt{\text{Var}(x) \cdot \text{Var}(y)}}$$

$$r_{xy} = 0.5$$

Question 3

The intersecting point of the two regression lines: y on x and x on y is

- (a) $(0_1, 0)$ (b) (\bar{x}, \bar{y})
(c) (b_{yx}, b_{xy}) (d) (1, 1)

Answer: b

Explanation:

Properties of Regression Lines There are two lines of regression. Both these lines are known to intersect at a specific point (\bar{x}, \bar{y}) Here the variables under consideration are x and y.

Question 4

Given that the variance of x is equal to the square of standard deviation by and the regression line of y on x is $y = 40 + 0.5(x - 30)$. Then regression line of x on y is

- (a) $y = 40 + 4(x - 30)$ (b) $y = 40 + (x - 30)$
(c) $y = 40 + 2(x - 30)$ (d) $x = 30 + 2 + 2(x - 40)$

Answer: d

Explanation:

Question 5

The regression coefficient remain unchanged due to

- (a) A shift of scale
 (b) A shift of origin
 (c) Replacing x – values by $\frac{1}{x}$
 (d) Replacing y values by $\frac{1}{y}$

Answer: b

Explanation:

The regression coefficient remain unchanged due to A shift of origin

By properties of regression line we have, The regression coefficients remain unchanged due to a shift of origin but change due to a shift of scale.

JULY 2021

Question 1

If the sum of the product of the deviation of and Y from their means is zero correlation coefficient between X and Y is:

- (a) Zero
 (b) Positive
 (c) Negative
 (d) 10

Answer: Options (a)

Explanation:

Given: sum of the product of deviations of x and y series from their mean is zero,

To Find: the coefficient of correlation

$r =$ coefficient of correlation

$r = S_{xy} / (S_x \cdot S_y)$

Correlation coefficient = $\text{cov}(x,y) / (\text{std deviation}(x) \times \text{std deviation}(y))$

product of deviations of x and y series from their mean is zero

$\Rightarrow S_{xy} = 0$

$\Rightarrow r = 0$

Coefficient of correlation = 0

Ans: If the sum of the product of deviations of x and y series from their mean is zero, then the coefficient of correlation will be ZERO

Question 2

If the slope of the regression line is calculated to be 5.5 and the intercept 15 then the value of Y when X is 6 is

- (a) 88
 (b) 48
 (c) 18
 (d) 78

Answer: Options (b)

Explanation:

The value of Y when X is 6

$a+bX$
 $15+5.5(6)$
 Ans: 48

Question 3

If $y = 9x$ and $X = 0.01Y$, then r is equal to:

- (a) -0.1 (b) 0.1
 (c) 0.3 (d) -0.3

Answer: Options (c)

Question 4

The straight - line graph of the linear equation $Y = a + b X$, slope is horizontal if:

- (a) $b = 1$ (b) $b \neq 0$
 (c) $b = 0$ (d) $a = b \neq 0$

Answer: Options (c)

Question 5

If $b_{xy} = -1.6$ and $b_{yx} = -0.4$, then r_{xy} will be

- (a) 0.4 (b) -0.8
 (c) 0.64 (d) 0.8

Answer: Options (b)

DEC 2021

Question 1

If the data points of (X,Y) series on a scatter diagram lie along a straight line that goes downwards as X-values move from left to right, then the data exhibit ----- correlation.

- (a) Direct (b) Imperfect indirect
 (c) Indirect (d) Imperfect direct

Answer: c

Explanation:

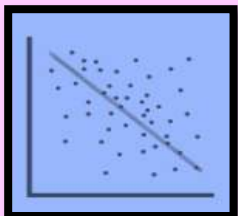

This is a Perfect Negative correlation, or indirect correlation.

Question 2

For any two variables x and y the regression equations are given as $2x + 5y - 9 = 0$

and $3x - y - 5 = 0$. What are the A.M. of x and y ?

- (a) 2, 1 (b) 1, 2
(c) 4, 2 (d) 2, 4

Answer: a

Explanation:

The regression lines intersect at the means of x and y . Therefore, the common point of intersection of these two lines will give the means of X and y . This means that the means of x and y will satisfy these two equations simultaneously.

We can either solve these two equations simultaneously or find out the values of x and y , which will give us our means; or, we can simply try the options.

Option (a) - 2, 1

Putting the value of $x = 2$, and $y = 1$ in the equation

$2x + 5y - 9 = 0$, we get

LHS = $2(2) + 5(1) - 9 = 0 = \text{RHS}$

Putting the value of $x = 2$, and $y =$ in the equation

$3x - y - 5 = 0$, we get

LHS = $3(2) - 1 - 5 = 0 = \text{RHS}$

Therefore, option (a) is the answer.

Question 3

The intersecting point of two regression lines falls at X-axis. If the mean of X-values is 16, the standard deviations of X and Y are respectively, 3 and 4, then the mean of Y-values is

- (a) $16/3$ (b) 4
(c) 0 (d) 1

Answer: c

Explanation:

The intersecting point of two regression lines gives the means of x and y . Since the point of intersection falls on the x -axis, the value of y is 0. Therefore, the mean of y -values is zero.

Question 4

The regression coefficients remain unchanged due to

- (a) Shift of origin (b) Shift of scale
(c) Always (d) Never

Answer: a

Explanation:

The regression coefficient remain uncharged due to shift of origin.

JUNE 2022

Question 1

If Coefficient of correlation for $3X + 4y = 6$ is 0.5. Find the coefficient of correlation for $3u + 9v = 7$ for u and v .

- (a) $-(0.5)$ (b) (0.5)
 (c) $\neq 0.5$ (d) 0.25

Answer: b

Explanation:

We know that shift of scale coefficient of (under consideration) then $r_{xy} = r_{uv} = 0.5$ correlation is change

Question 2

Karl Pearson Correlation Coefficient method is used for -

- (a) Any data (b) Scattered data
 (c) Grouped data (d) Ungrouped data

Answer: d

Explanation:

Karl Pearson Correlation Coefficient method is used for ungrouped data.

Question 3

If the plotted point in a scatter diagram lie from lower left to upper right then correction is:

- (a) Positive (b) Negative
 (c) Perfectively Negative (d) Zero

Answer: a

Explanation:

If the plotted point in a scatter diagram lie from lower left to upper right then it is said to be positive correlation.

Question 4

If concurrent coefficient is $\frac{1}{\sqrt{3}}$. If sum of deviation is n 6 for n pairs of data?

- (a) 9 (b) 8
 (c) 10 (d) 11

Answer: c

Explanation:

Given $r_c = \frac{1}{\sqrt{3}}$, $n = ?$

$C = 6$

Coeff of concurrent deviation

$$r_c = \pm \sqrt{\frac{2c - m}{m}}$$

$$\frac{1}{\sqrt{3}} = \pm \sqrt{\frac{2 \times 6 - m}{m}}$$

On squaring both side

$$\left[\frac{1}{\sqrt{3}}\right]^2 = \left[\pm \sqrt{\frac{12 - m}{m}}\right]^2$$

$$\frac{1}{3} = \frac{12 - m}{m}$$

$$m = 36 - 3m$$

$$m + 3m = 36$$

$$4m = 36$$

$$m = \frac{36}{4} = 9$$

$$n = m + 1 = 9 + 1 = 10$$

Question 5

Which of the following is used to find correlation between two qualitative characteristics

- | | |
|--------------------------|-------------------------------|
| (a) Karl Pearson | (b) Spearman rank correlation |
| (c) Concurrent deviation | (d) Scatter diagram |

Answer: b

Explanation:

Spearman's rank correlation coefficient is used to find correlation between two qualitative characteristics.

Question 6

Scattered diagram is used to plot

- | | |
|-----------------------|----------------------|
| (a) Quantitative data | (b) Qualitative data |
| (c) Discrete data | (d) Continuous data |

Answer: a

Explanation:

Scattered diagram is used to plot quantitative data.

DEC 2022

Question 1

The equations of the two lines of regression are $4x + 3y + 7 = 0$ and $3x + 4y + 8 = 0$, Find the correlation coefficient between x and y?

- | | |
|----------|---------|
| a) -0.75 | b) 0.25 |
| c) -0.92 | d) 1.25 |

Answer: Options (a)

Explanation:

$$4x+3y-7 \dots(i)$$

$$3x+4y -8 \dots(ii)$$

$$\text{Eqn.(i)} \times 3 - \text{eqn (ii)} \times 4$$

$$12x + 9y = -21$$

$$-12x - 16y = 32$$

$$-7y = 11$$

$$y = \frac{-11}{7}$$

Putting value of y in eqn (i) $x = -4/7$. Therefore,

$$\bar{x} = -\frac{4}{7}; \bar{y} = -\frac{11}{7}$$

$$\text{Coefficient of Correlation } |r| = \sqrt{b_{yx}b_{xy}} = \sqrt{\frac{-3}{4} \times \frac{-3}{4}}$$

$$r = \pm \frac{-3}{4} = -0.75$$

Question 2

If the regression equation are $2x+3y+1 = 0$ and $5x + 6y + 1 = 0$, then Mean of x and y respectively are

a) -1, -1

b) -1, 1

c) 1, -1

d) 2, 3

Answer: Options (c)

Explanation:

By option c

$$\text{Putting } x=1 \quad y=-1$$

$$2(1) + 3(-1) + 1 = 0$$

$$5(1) + 6(-1) + 1 = 0$$

$$x = 1, y = -1$$

Question 3

If $b_{yx} = 0.5$, $b_{xy} = 0.46$ then the value of correlation coefficient r is:

a) 0.23

b) 0.25

c) 0.39

d) 0.48

Answer: Options (d)

Explanation:

Correlation coefficient is the geometric mean between regression coefficients i.e.,

$$r = \pm \sqrt{b_{yx}b_{xy}}$$

$$r = \pm \sqrt{0.5 \times 0.46} = \pm 0.479$$

$$= 0.48$$

c) 0.49

d) 0.278

Answer: Options (b)

CHAPTER - 18 INDEX NUMBER

UNIT - I INDEX NUMBER

INTRODUCTION



An index number is a ratio or an average of ratios expressed as a percentage two or more time periods are involved, one of which is base time period.

The value of the base time period serves as the standard point of composition

ISSUES INVOLVED

Selection of data

Selection of Base Year

Types of Formula

Selection of weights

The data for Index Numbers

Choice of Variables

FEATURES OF INDEX NUMBER

Specialized Averages

Measure the net change in a group of related variables

Measures the affect of changes over a period of time

METHODS

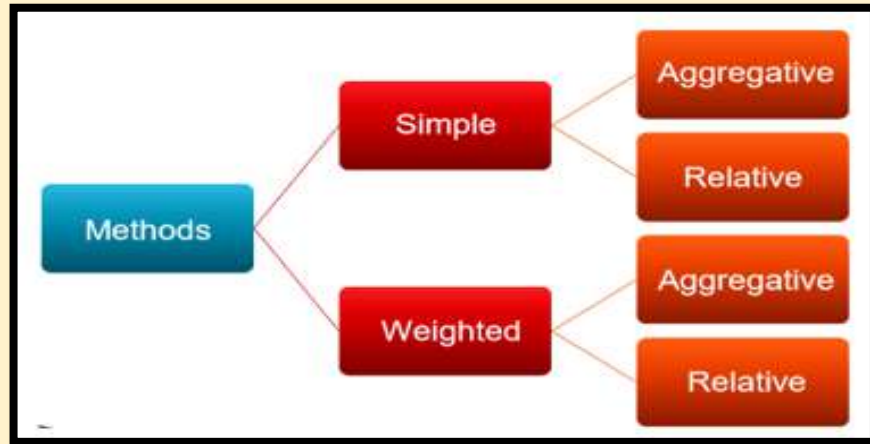

PRICE RELATIVE

Price relatives are helpful in understanding and interpreting changing economic and business conditions over time.

A price relative shows how the current price per unit for a given item compares to a base period price per unit for the same item.

A price relative expresses the unit price in each period as a percentage of the unit price in the base period

AGGREGATE PRICE INDEXES

An aggregate price index is developed for the specific purpose of measuring the combined change of a group of items

An unweighted aggregate price index in period t ,

1

Laspyre's Price index number

$$P_{01} = \frac{\sum p_1 q_0}{\sum p_0 q_0} \times 100$$

Where

- › P₁=Price of the current year
- › P₀=Price of the base year
- › q₀=Quantity of the base year

3

Marshall-Edgewoths's Price index number

$$\frac{\sum (q_0 + q_1) \times p_1}{\sum (q_0 + q_1) \times p_0} \times 100$$

› Where

- › P₁=Price of the current year
- › P₀=Price of the base year
- › q₀=Quantity of the current year
- › q₁=Quantity of the current year

5

Weighted Price index number

- › If Arithmetic Mean is used

$$P_{01} = \frac{\sum PV}{\sum V} \times 100 \quad P = \frac{P_1}{P_0} \times 100$$

› Where

- › P₁=Price of Current Year
- › P₀=Price of base year

$$V = P_0 q_0$$

2

Paasche's Price index number

$$P_{01} = \frac{\sum p_1 q_1}{\sum p_0 q_1} \times 100$$

› Where

- › P₁=Price of the current year
- › P₀=Price of the base year
- › q₁=Quantity of the current year

4

Fisher's Price index number

$$P_{01} = \sqrt{L \times P}$$

$$P_{01} = \sqrt{\frac{\sum p_1 q_0}{\sum p_0 q_0} \times \frac{\sum p_1 q_1}{\sum p_0 q_1}} \times 100$$

› Where

- › L= Laspyre's Price Index number
- › P=Paachee's Price Index number

6

Weighted Price index number

- › If Geometric Mean is used

$$P_{01} = \text{Anti log} \left[\frac{\sum V \log P}{\sum V} \right] \times 100$$

› Where

- › P₁=Price of Current Year
- › P₀=Price of base year
- › V=P₀q₀

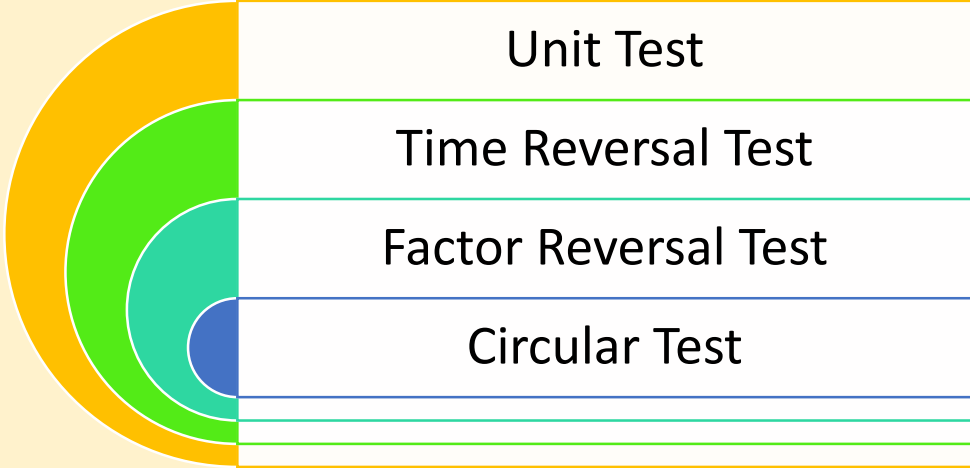
<p>QUANTITY INDEXES</p>	<p>An index that measures changes in quantity levels over time is called a quantity Index.</p> <p>Probably the best known quantity Index is the Index of Industrial Production.</p>
<p>QUANTITY INDEXES NUMBERS</p>	<ol style="list-style-type: none"> 1. Simple Aggregate of Quantities = $\frac{\sum Q_n}{\sum Q_0}$ 2. The simple average Quantity relatives $\frac{\sum Q_n}{\frac{\sum Q_0}{N}}$ 3. Weighted Aggregate Quantity indices <ol style="list-style-type: none"> i. With base year weight (Laspyres’s Index) $\frac{\sum Q_n P_0}{\sum Q_0 P_0} \times 100$ ii. With Current year weight (Paasche’s Index) $\frac{\sum Q_n P_n}{\sum Q_n P_n} \times 100$ iii. Geometric Mean of (1) and (2) $\sqrt{\frac{\sum Q_n P_0 \sum Q_n P_n}{\sum Q_0 P_0 \sum Q_0 P_n}} \times 100$ iv. Base year average of quantity relatives $\frac{\sum \frac{Q_n}{Q_0} \times (P_0 Q_0)}{\sum P_0 Q_0} \times 100$
<p>VALUE INDEX NUMBER</p>	$\frac{\sum V_n}{\sum V_0} = \frac{\sum P_n Q_n}{\sum P_0 Q_0}$
<p>TEST OF ADEQUACY OF INDEX NUMBERS</p>	
<p>UNIT TEST</p>	<p>The Unit test requires that the formula for constructing an index should be independent of the units in which, prices and quantities are quoted. All formulae except the simple (un weighted) aggregate index formula satisfy this test.</p>

<p>TIME REVERSAL TEST</p>	<p>A method satisfies time reversal test if it gives $P_{01} \times P_{10} = 1$ Where P_{01} is the price index number for the current year P_{10} is the index number of the base year, taking current year as the base, Both the indices without the factor 100.</p>						
<p>FACTOR REVERSAL TEST</p>	<p>A method satisfies factor reversal test if it gives</p> $P_{01} \times q_{01} = \frac{\sum p_1 q_1}{\sum p_0 q_0}$ <p>Where P_{01} is the price index for the current year q_{01} is the quantity index for the current year Fishers index number only satisfies the factor reversal test</p>						
<p>CHAIN BASE INDEX NUMBERS</p>	<p>Chain base index numbers is one in which the figures for each are first expressed as percentage of the preceding year. The percentage of chained together by successive multiplication to form a series of chain index, in chain base year index method the base year changes from year to year</p> $\frac{\text{Link relative of current year} \times \text{chain index Previous year}}{\frac{100}{\text{Current year Price Index}} \times 100}$						
<p>SPLICING</p>	<p>Technique of linking two or more index number series with same items and a common overlapping year but with different base period in order to form a continuous series. Splicing may be forward or backward</p> <p>Forward Splicing</p> <table border="1" data-bbox="470 1664 1481 1973"> <tr> <td>Splicing</td> <td>Index no. of old series</td> <td>Index no. of new series</td> </tr> <tr> <td>Backward Splicing</td> <td>No change</td> <td>= (Index number of old series/100) × Given index No. of new series</td> </tr> </table>	Splicing	Index no. of old series	Index no. of new series	Backward Splicing	No change	= (Index number of old series/100) × Given index No. of new series
Splicing	Index no. of old series	Index no. of new series					
Backward Splicing	No change	= (Index number of old series/100) × Given index No. of new series					

	<p>Index number using new base</p> $\frac{\text{Index Number using new base}}{\text{Old index number using old base}} \times 100$ $\frac{\text{Index number Corresponding new base year}}{\text{Old index number using old base}} \times 100$
<p>USES OF INDEX NUMBERS</p>	<ol style="list-style-type: none"> 1. As the indices are constructed mostly from deliberate samples, chances of errors creeping in cannot be always avoided. 2. Since index numbers are based on some selected items, they simply depict the broad trend and not the real picture. 3. Since many methods are employed for constructing index numbers, the result gives different values and this at times create confusion. <p>Deflated Time series using index Numbers</p> $\text{Delated Value} = \frac{\text{Current value}}{\text{Price index of the current year}} \text{ or}$ $= \text{Current Value} \times \frac{\text{Base price } (P_0)}{\text{Current Price } (P_n)}$
<p>LIMITATIONS OF INDEX NUMBERS</p>	<p>As we know, our indices are of prices and quantities. The question is: does our index reflect a change in the quantity of a product or item?</p> <p>Apart from quantity changes, there are other aspects that are pertinent while we are interpreting index numbers. We have to ask whether the weights assigned to different items are appropriate.</p>
<p>METHODS OF CONSTRUCTING CONSUMER PRICE INDEX</p>	<p>Aggregate Expenditure method Family budget method</p> <p>Aggregate expenditure method is a weighted aggregated price index where weights are the base period quantities. (Laspyres's Index number)</p> $\text{CPI} = \frac{\sum p_1 q_0}{\sum p_0 q_0} \times 100$
<p>FAMILY BUDGET METHOD</p>	<p>Weighted Aggregated of price relatives</p> <p>Index is obtained by taking the average of weighted price relatives and the value weights are used</p> $\text{CPI} = \frac{\sum v_p p_1}{v_p p_0} \times 100$ $V = P_0 \cdot Q_0$

**Question 1**

Construct the following indices by taking 1997 as the base:

(i) Simple Aggregative price Index

Item	A	B	C	D	E
Price Rs. (1997)	6	2	4	10	8
Price Rs. (1998)	10	2	6	12	12
Price Rs. (1999)	15	3	8	14	16

(a) 140, 186.67

(b) 120.90, 140.6

(c) 140, 120.90

(d) 56,420

Answer: A

Explanation:

Item	P ₀	P ₁	P ₂	$P_1 = \frac{P_1}{P_0} \times 100$	$P_2 = \frac{P_2}{P_0} \times 100$
A	6	10	15	166.67	250
B	2	2	3	100.00	150
C	4	6	8	150.00	200
D	10	12	14	120.00	140
E	8	12	16	150	200
	$\sum P_0 = 30$	$\sum P_1 = 42$	$\sum P_2 = 56$	$\sum \left(\frac{P_1}{P_0} \times 100 \right) = 686.67$	$\sum \left(\frac{P_2}{P_0} \times 100 \right) = 940$

Simple Aggregative Price Index:

$$P_{01} = \frac{\sum P_1}{\sum P_0} \times 100 = \frac{42}{30} \times 100 = 140 \quad (\text{for 1998})$$

$$P_{02} = \frac{\sum P_2}{\sum P_0} \times 100 = \frac{56}{30} \times 100 = 186.67 \quad (\text{for 1999})$$

Question 2

A composite price index where the prices of the item composite are weighted by their relative importance is known as the

(a) Price relative

(b) CPI

(c) Weight aggregate price

(d) None of these

Answer: C

Explanation:

Weight aggregate price index the ratio of the sum of weighted price of current and base time period multiplied by 100 is called weight aggregate price index. This index is calculated allocating weight to each commodity on the basis of their relative importance

Question 3

A weighted aggregate price index where the weight for each item is its current period quantity is called the

- (a) Aggregate index (b) Consumer index
(c) Laspeyres index (d) Paasche index

Answer: D

Explanation:

Paasche index, index developed by German economist Herman Paasche for measuring current price or quantity levels relative to those of selected base period. It differs from the Laspeyres index in that it uses current – period weight

Question 4

An index that is designed to measure changes in quantities over time is known as the:

- (a) Quantity index (b) Time index
(c) Paasche index (d) None of these

Answer: A

Explanation:

Index number. As index number is an economic data figure reflecting price or quantity compared with a standard or base value. The base usually equals 100 and the index number is usually 100 times the ratio the base value.

Question 5

Index number is expressed in:

- (a) Ratio (b) Squares
(c) Percentages (d) Combination

Answer: C

Explanation:

Index numbers are value expressed as percentage of a single base figure. For example, if annual production of a particular chemical rose by 35% output in the second year was 135% of that in the first year. Index terms, output in the two years was 100 and 135 respectively. Index numbers have no units

Question 6

Indices calculated by the chain base method are free from:

- (a) Seasonal variation (b) Errors
(c) Percentages (d) Ratio

Answer: A

Explanation:

A value in any specific time period based on the value of the same entity in the preceding period. Changes in the value can be compared between sequential time periods. This differs from a fixed base index in which value in any period are based on the initial value.

Question 7

Consumer price index number is obtained by:

- (a) Laspeyres formula (b) Fisher ideal formula
(c) Marshall Edgeworth formula (d) Paasche formula

Answer: A

Explanation:

Laspeyres formula. Laspeyres suggested this index formula in 1871, in case of calculating the price index, assuming that for individual item. Price at the base period to be $P_i 0$, and quantity at the base period to be $Q_i 0$, the following equation is called "Laspeyres formula".

Question 8

The most appropriate average the price relatives is:

- | | |
|------------------|--------------------|
| (a) Median | (b) Harmonic mean |
| (c) Article mean | (d) Geometric mean |

Answer: D

Explanation:

Geometric mean index number is a multiplicative aggregation of (price or quantity) ratio with their importance exponents /weight derived from one or literature on index number theory

Question 9

The test which is not obeyed by any of the weighted index numbers unless the weights are constant:

- | | |
|--------------------------|------------------------|
| (a) Circular test | (b) Time reversal test |
| (c) Factor reversal test | (d) None of them |

Answer: A

Explanation:

According to this test the product of price index must be equal to the value index. Note 1. Since Fisher index number satisfied both time reversal test, it is called an ideal index number, Circular test it is generalized of the time reversal test.

Question 10

Index number having upward bias is:

- | | |
|---------------------|------------------------------|
| (a) Laspeyres index | (b) Paasche's index |
| (c) Fisher's index | (d) Marshall Edgeworth index |

Answer: B

Explanation:

Paasche index, index developed by German economist Herman Paasche for measuring current price or quantity level relative to those of a selected base period. It differs from the Laspeyres index in that it uses current period weighting.

Question 11

Marshall Edgeworth price index was proposed by:

- | | |
|-----------------------------|----------------------------|
| (a) One English economist | (b) Two English economist |
| (c) Three English economist | (d) Many English economist |

Answer: b

Explanation:

The Marshall – Edgeworth index credited to Marshall (1887) and Edgeworth (1925) is a weight relative of current period to base period set of price. This index uses the arithmetic average of the current and base period quantities for weighting. It is considered a pseudo – superlative formula and is symmetric.

Question 12

Paasche's price index number is also called

- | | |
|------------------------------|--------------------------|
| (a) Base year weight | (b) Current year weight |
| (c) Simple aggregative index | (d) Consumer price index |

Answer: B**Explanation:**

Passche index, index developed by German economist Herman Passche for measuring current price of quantity level to those of selected base period. it differs from the Laspeyres index in that it uses current period weight

Question 13

The major groups for whom the consumer price index number are constructed in India

- (a) The industrial workers (b) The urban non- manual workers and
(c) The urban agriculture (d) All of these

Answer: D**Explanation:**

Consumer price index member are having types:

The industrial worker

The urban non – manual worker and

The agriculture labors.

Question 14

From the following data construct price index of 1995 taking 1990 as base by using Average price Relative Method:

Commodity	A	B	C	D
Price in 1990 Rs.	60	45	80	25
Price in 1995 Rs.	75	50	70	40

- (a) 120.90 (b) 12.60
(c) 809.56 (d) 12.888

Answer: A**Explanation:**

Commodity	P ₀	P ₁	$\frac{P_1}{P_0} \times 100$
A	60	75	125
B	45	50	111.11
C	80	70	87.50
D	25	40	160
Total	210	235	

Question 15

Calculating weighted aggregate price index from the following data using Laspeyre's method

Base Period	Current period			
	Quantity Price		Quantity	
A	2	10	4	5
B	5	12	6	10
C	4	20	5	15
D	2	15	3	10

- (a) 155.09 (b) 12.60
(c) 135.26 (d) 12.888

Answer: C

Explanation:

Commodity	Price	Quantity (Q ₀)	Price	Quantity	P ₀ Q ₀	P ₁ Q ₀
A	2	10	4	5	20	40
B	5	12	6	10	60	72
C	4	20	5	15	80	100
D	2	15	3	10	30	45
					$\sum P_0Q_0 = 190$	$\sum P_1Q_0 = 257$

Laspeyre's Method

$$P_{01} = \frac{\sum P_1Q_0}{\sum P_0Q_0} \times 100 = \frac{257}{190} \times 100 = 135.2$$

Question 16

Calculate weighted aggregate price index member from the following data by using paasches method

Commodity	Base year		Current	
	Price	Quantity	Price	Quantity
A	10	30	12	50
B	8	15	10	25
C	6	20	6	30
D	4	10	6	20

- (a) 199.79
- (b) 119.79
- (c) 135.26
- (d) 12.888

Answer: B

Explanation:

P ₀ Q ₀	P ₀ Q ₁	P ₁ Q ₀	P ₁ Q ₁
300	500	360	600
120	200	150	250
120	180	120	180
40	80	60	120
$\sum 580$	$\sum 960$	$\sum 690$	$\sum 1150$

Paasche's price index: $P_{01} = \frac{\sum P_1Q_0}{\sum P_0Q_1} \times 100 = 119.79$

Question 17

Calculate Laspeyres and Passche index for the following data:

Commodity	1970		1990	
	Price	Expenditure	Price	Expenditure
A	8	100	10	90
B	10	60	11	66
C	5	100	5	100
D	3	30	2	24

E	2	8	4	20
----------	---	---	---	----

(a) 109.73, 107.91

(b) 119.79, 169.56

(c) 135.26, 0.465

(d) 135.26, 0.465

Answer: A**Explanation:**

Since we are given the expenditure and price we can obtain the quantity by dividing expenditure by the price for each commodity.

Commodity	1970		1990		P_0q_0	P_1q_0	P_0q_1	P_1q_1
	P_0	q_0	P_1	q_1				
A	8	12.5	10	9	100	125	72	90
B	10	6	11	6	60	66	60	66
C	5	20	5	20	100	100	100	100
D	3	10	2	12	30	20	36	24
E	2	4	4	5	8	16	10	20
					$\sum P_0q_0 = 298$	$\sum P_1q_0 = 327$	$\sum P_0q_1 = 278$	$\sum P_1q_1 = 300$

(i) Laspeyre's Method: $P_{01} = \frac{\sum p_1q_0}{\sum p_0q_0} \times 100$

$$= \frac{327}{298} \times 100$$

$$= 109.73$$

(ii) Paasche's Method: $P_{01} = \frac{\sum p_1q_1}{\sum p_0q_1} \times 100$

$$= \frac{300}{278} \times 100$$

$$= 107.91$$

Question 18

Calculate weighted average of price relative index from the following data

Item	Weight in % (Rs)	Base year Price (Rs)	Current year Price (Rs)
A	40	2	4
B	30	5	6
C	20	4	5
D	10	2	3

(a) 215

(b) 156

(c) 965

(d) 325

Answer: B**Explanation:**

Item	W	P_0	P_1	$R = \frac{P_1}{P_0} \times 100$	RW
A	40	2	4	$\frac{4}{2} \times 100 = 200$	8000
B	30	5	6	$\frac{6}{5} \times 100 = 120$	3600
C	20	4	5	$\frac{5}{4} \times 100 = 125$	2500
D	10	2	3	$\frac{3}{2} \times 100 = 150$	1500

Total	$\sum W = 10$				$\sum RW = 15600$
-------	---------------	--	--	--	-------------------

$$P_{01} = \frac{\sum RW}{\sum W} = \frac{15600}{10} = 156$$

Question 19

The monthly capital expenditure incurred by worker of an industrial center during 1980 and 2005 on the following item are given below: The weights of these item are 75,10,5,6 and 4 respectively Prepare a weighted index number cost of living for 2005 with 1980as base.

Item	Price in 1980	Price in 2005
Food	100	200
Clothing	20	25
Fuel and Lighting	15	20
Music	30	40
House Rent	35	65

- (a) 185 (b) 156
(c) 165 (d) 325

Answer: A**Explanation:**

Item	W	P ₀	P ₁	$R = \frac{P_1}{P_0} \times 100$	RW
Food	75	100	200	200	15000
Clothing	10	20	25	125	1250
Fuel and Light	5	15	20	133.33	666.65
Music	6	30	40	133.33	799.98
House Rent	4	35	65	185.71	742.84
					$\sum PW = 18459.47$

$$CPI = \frac{\sum RW}{\sum W} = \frac{18459.47}{10} = 184.59 = 185 \text{ (Approx)}$$

Question20

An enquiry into the budget of the middle-class families in a certain city gave the following information:

Expenses on Item	Food 35%	Fuel 10%	Clothing 20%	Rent 15%	Music 20%
Price in 2004 (Rs.)	1500	250	750	300	400
Price in 1995 (Rs.)	1400	200	500	200	250

What is the cost of living index of 2004 as compared with 1995?

- (a) 165.62 (b) 134.5
(c) 165.60 (d) 325.8

Answer: B**Explanation:**

Item	Win %	P ₀	P ₁	$R = \frac{P_1}{P_0} \times 100$	RW
Food	35	1400	1500	107.14	3750

Fuel	10	200	250	125.00	1250
Clothing	20	500	750	150.00	3000
Rent	15	200	300	150.00	2250
Music	20	250	400	160.00	3200

$$CPI = \frac{\sum RW}{\sum W} = \frac{13450}{100} = 134.5$$

Question 21

Calculate the cost of living index number using family budget method

Commodities	Wheat	Rice	Pulses	Ghee	Sugar	Oil	Fuel	Cloths
Unit consumed in	200	50	56	20	40	50	60	10
Price Rs. in Bose	1.0	3.0	4.0	20.0	2.5	10.0	2.0	15.0
Price Rs. InC.Y	1.2	3.5	5.0	30.0	5.0	15.5	2.5	18.0

- (a) 166.62
(c) 165.870
- (b) 136.88
(d) 325.8

Answer: B

Explanation:

Commodities	Q ₀	P ₀	P ₁	$R = \frac{P_1}{P_0} \times 100$	W = P ₀ q ₀	RW
Wheat	200	1.0	1.2	120.00	200	24000
Rice	50	3.0	3.5	116.67	150	17500.5
Pulses	56	4.0	5.0	125.00	224	28000
Ghee	20	20.0	30.0	150.00	400	60000
Sugar	40	2.5	5.0	200.00	100	20000
Oil	50	100	15.5	155.00	500	77500
Fuel	60	2.0	2.5	125.00	120	15000
Cloths	40	15.0	18.0	120.00	600	72000
					$\sum W = 22$	$\sum RW =$

$$CPI = \frac{\sum RW}{\sum W} = \frac{314000.5}{2294} = 136.88$$

Question 22

If the salary of person in the base year is Rs. 4,000 per annum and the current year salary is Rs. 6,000 by how much should his salary rise to maintain the same standard of living if The CPI of the current year is 400?

- (a) 10000
(c) 165870
- (b) 13688
(d) 16000

Answer: D

Explanation:

Salary required in the current year to maintain the same standard of living of base year.

$$\text{Base year salary} \times \frac{\text{CPI OF CURRENT YEAR}}{\text{CPI OF base year}} = 4000 \times \frac{400}{100} \text{ Rs. } 16,000$$

Current year salary = Rs. 16,000

The increase in current Year salary required = 16000- 6000 = Rs. 10,000

Question 23

Given the following data:

Year	1995-	1996-	1997-	1998-	1999-	2000-	2001-	2002-
WPI (1993	121,6	127.2	132.8	140.7	145.7	155.7	161.3	161

Calculate the inflation of year 1998 – 99

- (a) 5.94% (b) 59.89%
(c) 4.4% (d) None

Answer: A

Explanation:

$$\text{Year 1996-97} = \frac{X_1 - X_{t-i}}{X_{t-i}} \times 100 = \frac{127.2 - 121.6}{121.6} \times 100 = 4.6\%$$

$$\text{Year 1997-98} = \frac{X_1 - X_{t-i}}{X_{t-i}} \times 100 = \frac{132.8 - 127.2}{127.2} \times 100 = 4.40\%$$

$$\text{Year 1998-99} = \frac{X_t - X_{t-i}}{X_{t-i}} \times 100 = \frac{140.7 - 132.8}{132.8} \times 100 = 5.94\%$$

Question 24

What will be the real wage of the consumer if his money wages Rs. 10 and the cost of living index is 526?

- (a) 1900 (b) 1.901
(c) 2186 (d) 4664

Answer: B

Explanation:

$$\text{Real wages} = \frac{\text{Money Wages}}{\text{Cost of living index}} \times \frac{10.000}{526} \times 100 = \text{Rs. 1.901}$$

Question 25

Index for base period is always taken as:

- (a) 100 (b) 0
(c) 200 (d) 1

Answer: A

Explanation:

The index at the base period is usually scaled to 100 or 1000. for example, that the index at the chosen base period is set to 1000. if at another period is 2000 then the value indicated by the index (e.g., prices) would be estimate double what it was during the base period.

Question 26

When the prices of rice are to be compared, we compute:

- (a) Volume Index (b) Value Index
(c) Price Index (d) Aggregate Index

Answer: C

Explanation:

Price index. Measure of relative price changes, consisting of a series of numbers are arranged so that a comparison between the values for any two period of places will show the average changes in price between period or the average difference in prices between places.

Question 27**Which formula is used in chain indices?**

- (a) $\frac{\sum P_n}{\sum P_o} \times 100$ (b) $\frac{P_n}{P_{n-1}}$
 (c) $\frac{P_n}{P_o}$ (d) None

Answer: B**Explanation:**

In the chain index the comparison takes place always between successive calculation periods. In the chain index the changes in two calculation periods is used to take forward the index point figure of the desired base period in the chain index the weight are changed in principal in each calculation period.

Question 28**An index number that can serve purpose is called**

- (a) General purpose index (b) Special purpose index
 (c) Cost of living index (d) None of these

Answer: A**Explanation:**

It is used measure the Changes in the wholesale price level of country over a period of time. It is used measure the changes in the cost of living of a certain selected people living in a certain locally.

It is very much used by the government agencies to for policies on different matter viz.

Question 29**Laspeyres index = 110, Paasche index = 108 then fisher ideal index equal to:**

- (a) 110 (b) 108
 (c) 100 (d) 109

Answer: D**Explanation:**

$$F = \sqrt{L \times P}$$

$$\text{So. } \sqrt{110 \times 108} = 109$$

Question 30**Consumer price indexes are obtained by:**

- (a) Paasche formula (b) Fisher`s ideal formula
 (c) Marshall Edgeworth formula (d) Family budget method formula

Answer: d**Explanation:**

A consumer price index (CPI) measure changes in the price level of market basket of consumer goods and services purchased by household, The CPI is a statistical estimate constructed using the price of a simple of representative item whose prices are collected periodically.

Question 31**Which of the following satisfy the time reversal test?**

- (a) $P_{01} = \frac{\sum P_1 q_0}{\sum P_0 q_0}$ (b) $P_{01} = \frac{\sum P_1 q_1}{\sum P_0 q_1}$
 (c) $P_{01} = \sqrt{\frac{\sum P_1 q_0}{\sum P_0 q_0} \times \frac{\sum P_1 q_1}{\sum P_0 q_1}}$ (d) None

Answer: C

Explanation:

Factor reversal test time reversal test This test is proposed by Living fisher According to him an index number (formula) should be such that when the base year and current year are interchanged (reversed) the resulting number should be the reciprocal of the earlier.

Question 32

Simple average method of relative method is equal to:

- (a) $\frac{P_n}{P_o} \times 100$ (b) $\frac{\sum P_n}{\sum P_o} \times 100$
 (c) $\sum \left(\frac{p_n}{P_o}\right) \times 100$ (d) $\frac{1}{N} \sum \left(\frac{P_n}{P_o}\right) \times 100$

Answer: D

Explanation:

In case of un weighted average of relative price relative of each commodity is first calculated and then the average (mean, median, or geometric mean) of these price relatives for all the commodities is taken average of relatives can be calculated by taking arithmetic mean, geometric mean or median as average.

Question 33

Link relative of current year is equal to:

- (a) $\frac{\text{Price of the current year}}{\text{price of the base year}} \times 100$ (b) $\frac{\text{Price of the base year}}{\text{price in the preceding year}} \times 100$
 (c) $\frac{\text{Price in the current year}}{\text{price in the preceding year}} \times 100$ (d) $\frac{\text{Price in the preceding year}}{\text{price in the current year}} \times 100$

Answer: C

Explanation:

This method of finding the seasonal indices in the form of the chain relatives was

$$(C) \frac{\text{PRICE IN THE CURRENT YEAR}}{\text{PRICE IN THE PRECEDING YEAR}} \times 100$$

Development by Prof. Karl Person and hence this method is also known as the person method of seasonal variation Hence is correct answer.

Question 34

Marshall Edge worth price index was proposed by:

- (a) Only English economist (b) Two English economist
 (c) Three English economist (d) May English economist

Answer: B

Explanation:

The Marshall Edgeworth index credited to Marshall (1887) and Edgeworth (1925) is a weighted relative current period to base period seats of prices this index uses the arithmetic a pseudo- superlative formula and is symmetric.

Question 35

Write down formula calculating inflation rate:

- (a) $\frac{X_1 X_{t-1}}{X_{1-1}} \times 100$ (b) $\frac{\sum P_n q_n}{\sum P_o q_o} \times 100$
 (c) $\frac{P_a}{P_{a-1}} \times 100$ (d) None

Answer: A

Explanation:

$$\text{Inflation rate} = \frac{X_t - X_{t-i}}{x_{t-i}} \times 100$$

Where X_t refers to WPI for the $(t)^{\text{th}}$ week

X_{t-1} refers to WPI for the $(t - 1)^{\text{th}}$ week.

Question 36

If all the values are not equal importance the index number is called

- (a) Simple (b) Un weighted
(c) Weighted (d) None

Answer: C

Explanation:

When all commodities are not equal importance, we assign to each commodity relative to its importance and the index computed from the weight is called weighted index number

Question 37

In fixed base method the base period should be:

- (a) For away (b) Abnormal
(c) Unreliable (d) Normal

Answer: D

Explanation:

The value in any specific time period is based on the value in the initial time period and this base remains unchanged through the index. This is different from chain base index in which values in any period are based on the preceding time period

Question 38

How many types are used in the calculation number?

- (a) 2 (b) 3
(c) 4 (d) 5

Answer: B

Explanation:

Index number are used as an indicate the changes in economic activity they also provide framework for decision making and to period future event. There are three types of index number are generally used they are price index, quantity index, and value index.

PAST EXAMINATION QUESTIONS:

MAY 2018

Question 1

A series of numerical figure show the relative position is called:

- (a) Index number (b) Relative number
(c) Absolute number (d) None

Answer: A

Explanation:

A series of numerical figures which show the relative called Index Number:

Question 2**P01 is the index for time:**

- (a) 1 on 0 (b) 0 on 1
(c) 1 on 1 (d) 0 on 0

Answer: A**Explanation:**

P01 is the index number 1 on 0.

Question 3**if $\sum P_0 Q_0 = 1360$, $\sum P_n Q_0 = 1990$, $\sum P_0 Q_n = 1344$, $\sum P_n Q_n = 1880$ then the Laspeyres' index number is:**

- (a) 0.71 (b) 1.39
(c) 1.75 (d) None

Answer: B**Explanation:**

if. if $\sum P_0 Q_0 = 1360$, $\sum P_n Q_0 = 1990$, $\sum P_0 Q_n = 1344$, $\sum P_n Q_n = 1880$ then the Laspeyres' index no. $\frac{\sum P_n Q_0}{\sum P_0 Q_0} = \frac{1990}{1360} = 1.3970$

Question 4**Price relative is expressed in term of**

- (a) $P = \frac{P_n}{P_0}$ (b) $P = \frac{P_0}{P_n}$
(c) $P = \frac{P_1}{P_0} \times 100$ (d) $P = \frac{P_0}{P_n} \times 100$

Answer: C**Explanation:**Price relative $P = \frac{P_1}{P_0} \times 100$ **Question 5****Circular test is satisfied by:**

- (a) Laspeyres' index number (b) Paasche index number
(c) The simple geometric mean of price relatives and the weighted aggregative weight (d) None of these

Answer: C**Explanation:**

Circular test is satisfied by the simple geometric mean of price relative weighted aggregative with fixed weighted

Question 6

If the 1970 index with base 1956 is 200 and 1965 index weighted 150 the index 1970 on base 1960 will be:

- (a) 700 (b) 300
(c) 500 (d) 600

Answer: B

Explanation:

Let 1960 1965 1970
 P_0 P_1 P_2

Index no. of 1965 with base year 1960

$$P_0 = \frac{P_2}{P_1} \times 100 = 150$$

$$\frac{P_1}{P_0} = \frac{150}{100}$$

Index no of 1970 with the base 1965

$$P_\infty = \frac{P_2}{P_1} \times 100 = 200$$

$$\frac{P_2}{P_1} = \frac{200}{100}$$

Multiply equation (1) (2)

$$\frac{P_1}{P_0} \times \frac{P_2}{P_1} = \frac{150}{100} \times \frac{200}{100}$$

$$\frac{P_2}{P_0} = 3$$

$$\frac{P_1}{P_0} = 100$$

$$\frac{P_2}{P_1} \times 100 = 3 \times 100$$

$$P_\infty = 300$$

Nov 2018

Question 1

Which of the following statement is true?

- (a) Passhe`s is index number is based on the base year quantity (b) Fisher index number is the arithmetic mean of Laspeyre`s index number and Paasche`s index number
(c) Arithmetic mean is the most appropriate average for constructing the index number (d) Fisher index number is an ideal index number

Answer: d

Explanation:

Fisher index number is an ideal index NO.

Question 2

It Laspeyre's index number is 250 and Paasche index number is 160 then Fisher index number is:

- (a) 40,000 (b) $\frac{25}{16}$
 (c) 200 (d) $\frac{25}{16}$

Answer: C

Explanation:

Laspeyre's index NO. (l) = 250

Paasche index NO. (p) = 160

Fisher index NO. (F) = $\sqrt{L \times P}$

$$= \sqrt{250 \times 160}$$

$$= \sqrt{40,000}$$

$$= 200$$

Question 4

If $\sum P_0 Q_0 = 240$, $\sum P_0 Q_1 = 480$, $\sum P_1 Q_0 = 600$, $\sum P_1 Q_1 = 192$ the Laspyres's index number is:

- (a) 250 (b) 300
 (c) 350 (d) 200

Answer: A

Explanation:

If $\sum P_0 Q_0 = 240$, $\sum P_0 Q_1 = 480$, $\sum P_1 Q_0 = 600$, $\sum P_1 Q_1 = 192$

Laspeyre's index no. $\frac{\sum P_1 Q_0}{\sum P_0 Q_0} = \frac{600}{240} \times 100$

$$= 250$$

May 2019

Question 1

The prices and quantities of 3 commodities in base and current year are as follow:

P_0	P_1	Q_0	Q_1
12	14	10	20
10	8	20	30
8	10	30	10
30	32	60	60

The Laspeyres price index is:

- (a) 128.13 (b) 107.14
 (c) 120.10 (d) None

Answer: B

Explanation:

$$LA = \frac{\sum P_1 Q_0}{\sum P_0 Q_0} \times 100$$

$$= \frac{32 \times 60}{30 \times 60} = \frac{1920}{1800} = 1.0777 \times 100$$

$$= 107.4$$

Question 2**Which is called an ideal index number?**

- (a) Laspeyre's index number (b) Paasche index number
 (c) Fisher index number (d) Marshall Edgeworth number

Answer: C**Explanation:**

the reason the fisher index is called the ideal index is twofold because the Paasche index and the Laspeyre's index. the index satisfies the time reversal test and the factor reversal test

Question 3**The most commonly used mathematical method for finding secular trend is:**

- (a) Moving average (b) Semi – average
 (c) Least squares (d) None of these

Answer: B**Explanation:**

This method is a simple and relatively objective as the free hand method the data is divided in two equal halves and the arithmetic mean of the two sets of modules of Y is plotted against the center of the relative time span It is the number of observations is even the division into halves will be straight forward

Question 4**Semi average method if the number of values is odd then we drop**

- (a) First value (b) Last value
 (c) Middle value (d) Middle two value

Answer: C**Explanation:**

If the number of observations is even the division into halves will be straight forward however if the number of observations is odd then the middle most item i.e., $\left(\frac{n+1}{2}\right)$ is dropped the two points so obtained are joined through a straight line which show the trend

Question 5**If Laspeyre's index is L and P Paasche index is P then Fisher index F is $F_2 = 1 \times P$**

- (a) $F = L \times P$ (a) $F_2 = L \times P$
 (c) $F_2 = \sqrt{L + P}$ (d) $F = \frac{1}{L \times P}$

Answer: B

Explanation:

If Laspeyre's index is L and Paasche index is P then Fisher index F is $F^2 = L \times P$

Nov 2019

Question 1

Fisher's index does not satisfy:

- | | |
|--------------------------|------------------------|
| (a) Circular test | (b) Time reversal test |
| (c) Factor reversal test | (d) Unit test |

Answer: A

Explanation:

Fisher's ideal formula for calculating index no. satisfies unit test as unit test require that the formula should be independent of the unit in which or for which prices and quantities are quoted and that is full filled by fisher's ideal index Factor reversal test hold when the product of price index and quantity index should be equal to corresponding value index i.e.

$$\frac{P_1 Q_1}{P_0 Q_0}$$

$$P_{01} \times Q_{01} = \frac{P_1 Q_1}{P_0 Q_0}$$

Hence it is satisfied by Fisher's Ideal index

Time reversal test is a test to determine whether a given method will work both ways in time forward and backward So fisher's satisfies this test

Circular test: It is concerned with the measurement of price change over a period of year this is not met by Fisher ideal index no.

Question 2

The index number of prices at place in the year 2008 is 225 with 2004 as the base then there is

- | | |
|-------------------|-------------------|
| (a) 125% increase | (b) 225% increase |
| (c) 100% increase | (d) 25% increase |

Answer: A

Explanation:

Let the index no. of price of base year be 100

Year index no.

2004 = 100

Increase = 225 - 100 = 125

So there is 125% increase.

Question 5

In semi average method if the no. of value is are exclude:

- (a) First value
(c) Middle value
- (b) Last value
(d) None

Answer: C

Explanation:

Semi average method is a method of measurement of secular trend. Under this method the whole the series data is classified into two equal parts and the average for each half are calculated. If the data is for even no. of year it is easily divided into two. If data is for odd no. of year then the middle year of the time series is left and the two halves are constituted with the period on each side of middle year.

DEC 2020

Question 1

Index Number are expressed as _____

- (a) Squares
(c) Percentages
- (b) Ratios
(d) Combinations

Answer: C

Explanation:

Index numbers provide a simple way of representing changes over time. Each value is expressed as a percentage of a base value which is the value that occurred in a base period. The index numbers below show how average earnings in different sectors changed between 2000 and 2006.

Question 2

If Laspeyre's index number is 110 and Fisher's ideal Index number is 109. Then Paasche's Index number is

- (a) 108
(c) 109
- (b) 110
(d) 118

Answer: A

Explanation:

Laspeyre's Index (L.I.) = 110

Paasche's Index (P.I.) = 108

Fisher's Ideal Index = $\sqrt{L.I. \times P.I.}$

= $\sqrt{110 \times 109}$

= 108

IAN 2021

Question 1

The cost of living index is always

- (a) Price index number
(c) Weighted index number
- (b) Quantity index number
(d) Value index number

Answer: C

Explanation:

The cost of living index is always Weighted index number - The cost-of-living index, or general index, shows the difference in living costs between cities. The cost of living in the base city is always expressed as 100. The cost of living in the destination is then indexed against this number.

Question 2

Fisher's index number does not satisfy.

- (a) Unit test
(c) Time reversal test
- (b) Circular Test
(d) Factor reversal test

Answer: B

Explanation:

The circular test is satisfied by Fisher's index number.

Question 3

When the prices for quantities consumed of all commodities are changing in the same ratio, then the index numbers due to Laspyres's and Paasche's will be

- (a) Equal
(c) Reciprocal of Marshall Edge worth index number
- (b) Unequal
(d) Reciprocal of Fisher Index number

Answer: A

Explanation:

When the prices for quantities consumed of all commodities are changing in the same ratio, then the index numbers due to Laspyres's and Paasche's will be equal

July 2021

Question 1

The consumer price Index goes up from 120 to 180 when salary goes up from 240 to 540, what is the increase in real terms?

- (a) 80
(c) 120
- (b) 150
(d) 240

Answer: Options (c)

Question 2

The weighted aggregative price index numbers for 2001 with 2000 as the base year using Paasche's Index Number is

Commodity	Price (in ₹)		Quantities	
	2000	2001	2000	2001
A	10	12	20	22
B	8	8	16	18
C	5	6	10	11
D	4	4	7	8

(a) 112.32

(b) 112.38

(c) 112.26

(d) 112.20

Answer: Options (d)**Question 3**

The weighted aggregative price index numbers for 2001 with 2000 as the base year using Marshal - Edge worth Number is

Commodity	Price (in ₹)		Quantities	
	2000	2001	2000	2001
A	10	12	20	22
B	8	8	16	18
C	5	6	10	11
D	4	4	7	8

(a) 112.26

(b) 112.20

(c) 112.32

(d) 112.38

Answer: Options (a)**Question 4**

The weighted aggregative price index numbers for 2001 with 2000 as the base year using Fisher's Index Number is

Commodity	Price (in ₹)		Quantities	
	2000	2001	2000	2001
A	10	12	20	22
B	8	8	16	18
C	5	6	10	11
D	4	4	7	8

(a) 112.32

(b) 112.20

(c) 112.32

(d) 112.38

Answer: Options (d)**DEC 2021****Question 1**

If P_{10} and P_{01} are index for 1 on 0 and 0 on 1 respectively then formula $P_{01} \times P_{10} =$

1 is used for

- (a) Unit test (b) Time Reversal Test
(c) Factor Reversal test (d) Circular Test

Answer:**Explanation:**

$P_{01} \times P_{10} = 1$ is used for 'Time Reversal Test'.

Question 2

The weighted averaged of price relatives of commodities, when the weights are equal to the value of commodities in the current year, yields _____ index number.

- (a) Fisher's ideal (b) Laspeyres's
(c) Paasches (d) Marshall Edgeworth

Answer: c**Explanation:**

The weighted Averaged of Price relatives of commodities, when the weights are equal to the value of commodities in the current year yield Paasche's Index No.

Question 3

From the following data base year:

Commodity	Base Year		Current year	
	Price	Quantity	Price	Quantity
A	4	3	6	2
B	5	4	6	4
C	7	2	9	2
D	2	3	1	5

Fisher's ideal Index is

- (a) 117.30 (b) 115.43
(c) 118.35 (d) 116.48

Answer: a**Explanation:**

Fisher's Index

$$= \sqrt{\frac{\sum P_n Q_0}{\sum P_0 Q_0} \times \frac{\sum P_n Q_n}{\sum P_0 Q_n}} \times 100$$

$$= \sqrt{\frac{(6 \times 3) + (6 \times 4) + (9 \times 2) + (1 \times 3) + (6 \times 2) + (6 \times 4)}{(4 \times 3) + (5 \times 4) + (7 \times 2) + (2 \times 3) + (4 \times 2) + (5 \times 4)}}$$

$$= \sqrt{\frac{63}{52} \times \frac{59}{52}} \times 100 = 117.3$$

Question 4**Index numbers are not helpful in**

- | | |
|--------------------------------|------------------------|
| (a) Framing economics policies | (b) Revealing trend |
| (c) Forecasting | (d) Identifying errors |

Answer: d**Explanation:**

Index numbers are not helpful in Identifying Errors.

Question 5**The three index numbers, namely, Laspeyre, Paasche and Fisher do not satisfy _____ test.**

- | | |
|-------------------|---------------------|
| (a) Time reversal | (b) Factor reversal |
| (c) Unit | (d) Circular |

Answer: d**Explanation:**

Laspeyre, Paasche and Fisher do not satisfy circular test.

JUNE 2022**Question 1****Geometric mean method used in which index number to find it out**

- | | |
|--------------------------|--------------|
| (a) Laspeyres | (b) Paasches |
| (c) Fishers index Number | (d) None |

Answer: c**Explanation:**

Geometric mean Method used in Fisher's Index No to find it out.

Question 2**Which test is known for shift base index no.**

- | | |
|-------------------|------------------------|
| (a) Factor test | (b) Unit test |
| (c) Circular test | (d) Time reversal test |

Answer: c**Explanation:**

Circular test is known for shift base Index No

Question 3**Laspeyre and Paasche do not satisfy -**

- | | |
|------------------------|-------------------|
| (a) Unit Test | (b) Factor Test |
| (c) Time Reversal Test | (d) Bowley's Test |

Answer: c

Explanation:

Laspeyres and Paasche do not satisfy 'Time Reversal Test'

Question 4

Laspeyres's index number is based on?

- (a) Last year weight (b) Present year weight
(c) Last year value (d) Present year value

Answer:**Explanation:**

Laspeyres Index Number is based on last year weight.

Question 5

Price relative is-

- (a) $\frac{P_1}{P_0 \times 100}$ (b) P
(c) P₀ (d) $\frac{P_1}{P_0}$

Answer: a**Explanation:**

Price relative (R) $\frac{P_1}{P_0} \times 100$

Question 6

Which one of the following is not appropriate for calculation of index number?

- (a) Unit Test (b) Price Relative Test
(c) Circular Test (d) Time Reversal Test

Answer: b**Explanation:**

Price Relative test is not appropriate for calculation of Index No.

DEC 2022**Question 1**

From the following data extract the index number by Laspeyres's method:

$\sum P_1 Q_1 = 460, \sum P_0 Q_0 = 140, \sum P_1 Q_0 = 350, \sum P_0 Q_1 = 200$

- a) 250 b) 240
c) 238.24 d) 276.04

Answer: Options (a)**Explanation:**

Laspeyres's Price Index = $\frac{\sum P_1 Q_0}{\sum P_0 Q_0} \times 100$

$$= \frac{350}{140} \times 100$$

= 250

Question 2

Which of the following index measures the changes from month to month in the cost of a representative “basket” of goods & services of the type which are bought by a typical household?

- | | |
|-------------------------|---------------------|
| a) Consumer Price Index | b) Laspeyre’s Index |
| c) Fisher’s Index | d) Paasche’s Index |

Answer: Options (a)

Explanation:

The consumer price index (CPI), a common measure of inflation, measures the price change over time for a basket of goods and services. The basket is representative of consumer spending patterns, and the change in its price represents the rate of inflation faced by consumers as a whole.

Question 3

Fisher’s Index is called an ideal index number because it satisfying

- | | |
|---------------------------------------|-----------------------|
| a) Factors reversal test | b) Time reversal test |
| c) Both factor and time reversal test | d) Circular test |

Answer: Options (c)

Explanation:

Fisher’s formula is called the ideal because of the following reasons:

- i) It is based on geometric mean which is considered best for constructing index numbers.
- ii) It fulfills both the time reversal and factor reversal tests.
- iii) It takes into account both current year as well as base year’s prices and quantities.
- iv) It is free from bias.

Question 4

If Laspeyre’s Index is 119 and Paasche’s Index is 112, then Fisher’s Index number will be:

- | | |
|-----------|-----------|
| a) 113.99 | b) 115.45 |
| c) 115.89 | d) 151.98 |

Answer: Options (b)

Explanation:

Laspeyre's Index (L.I.) = 119

Paasche's Index (P.I.) = 112

Fisher's Ideal Index = $\sqrt{L.I. \times P.I.}$
 $= \sqrt{119 \times 112}$
 $= 115.45$

Question 5

In price index, when a new commodity is required to be added, which of the following index is used?

- a) Shifted price index
- b) Splicing price index
- c) Deflating price index
- d) Value price Index

Answer: Options (a)

Explanation:

Splicing price index

