

UNIT - 1: INTRODUCTION

What is Economics about?

- ♣ Greek word '**Oikonomia**' which means **Household**
- ♣ 19<sup>th</sup> century Economics was known as '**Political Economy**'.
- ♣ An inquiry into the '**Nature and Causes of the wealth of Nations**' (1776), The wealth of Nations by **Adam Smith** (first modern work of economics)
- ♣ Two fundamental facts
  - Human being have **unlimited wants** and
  - The means to satisfy these unlimited wants are relative **scarc**

Meaning of business economics?

- ✚ Decision Making refers to the process of **selecting an appropriate alternative** that will provide the most efficient means of attaining a desired end, from two or more alternative course of action.
- ✚ Decision making is **not simple and straightforward**. It is highly complex and dynamic.
- ✚ Business economics **integrates economics theory with business practice**
- ✚ Business economics also **referred as managerial economics**.

Definition of business economics?

- ◆ The use of economic analysis to make business decisions involving **the best use of an organization's scarce resources**.
- ◆ **Joel Dean** defined business economics in terms of the use of **economics analysis in the formulation of business policies**. Business economics is essentially a component of applied economics.

Nature of Business Economics

Micro Economics

- ♥ Study of the behavior of different **individuals** (consumer and firms) and organization within an economic system.

Macro Economics

- ♠ Study of the overall economic phenomena or the **economy as a whole**.

Describing the nature of business economics

- *Economic world is complex and interdependence*
- *Economic theories are hypothetical and simplistic in nature*
- *Business economics is a science*
- *Based on macro economics*
- *Incorporates elements of Macro Analysis*
- *Business economics is also an Art*
- *Use of Theory of markets and private enterprises*
- *Pragmatic (practical way of dealings with problems) in approach*

## CHAPTER-1: NATURE AND SCOPE OF BUSINESS ECONOMICS

---

- *Interdisciplinary in Nature*
- *Normative in Nature (ought to be, descriptive in nature, involves value judgement) & Positive in nature (what is, no value judgement, cause and effect relationship )*

### Scope of Business Economics

1. Microeconomics applied to Internal or Operational issues:- that arise within the organization and fall within the purview and control of management.

- ✓ Demand analysis and Forecasting
- ✓ Production and cost analysis
- ✓ Inventory management
- ✓ Market structure and Pricing policies.
- ✓ Resource allocation
- ✓ Theory of capital and investment decisions
- ✓ Profit analysis
- ✓ Risk and uncertainty analysis

2. Macroeconomics applied to external or Environmental issues

- ✓ Economic system
- ✓ Business cycle
- ✓ National income, employment prices, saving and investment
- ✓ Fiscal policy, foreign trade policy, economic policies
- ✓ Central banks
- ✓ Unions and cooperatives
- ✓ Social and political environment.

**UNIT 2:- BASIC PROBLEM OF AN ECONOMY**

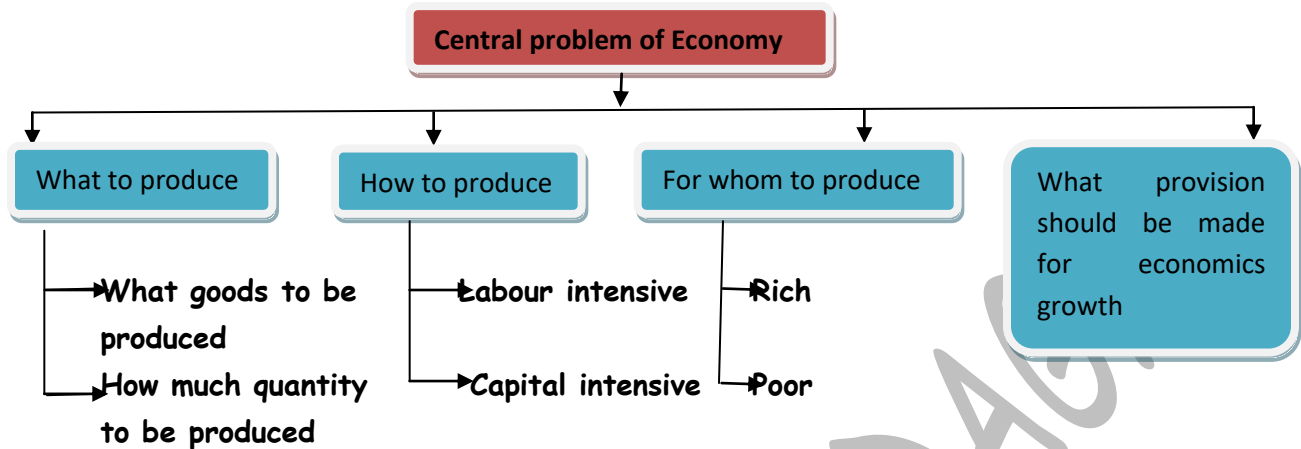

**CAPITALIST ECONOMY** (eg: United States and United Kingdom, Hong Kong, South Korea)

**Characteristics:**

- (i) Right to private property
- (ii) Freedom of enterprise
- (iii) Freedom of economic choice
- (iv) Profit motive
- (v) Consumer sovereignty
- (vi) Competition
- (vii) Absence of government interference

**How do capitalist economies solve their central problems?**

- ✚ Deciding what to produce - capital goods
- ✚ Deciding how to produce - capital intensive
- ✚ Deciding for whom to produce - rich
- ✚ Deciding about consumption, saving and investment - higher the level of income and interest rates, higher will be the savings. Greater the profit expectation greater will be investment.

**Merits of Capitalist Economy**

- ♣ Self regulating
- ♣ Profit motive
- ♣ Economic growth is faster
- ♣ Optimum allocation of resources
- ♣ Operating efficiency
- ♣ Cost of production is minimized

## CHAPTER 1 - NATURE AND SCOPE OF BUSINESS ECONOMICS

---

- ♣ *Incentive for efficient economic decisions and implementation*
- ♣ *Quality goods due to competition*
- ♣ *Incentive for innovation*
- ♣ *Fundamental right to property and right to freedom*
- ♣ *Democratic framework*

### Demerits of Capitalism

- ♣ *Economic inequality and social injustice*
- ♣ *Property rights over human rights*
- ♣ *Economic inequalities*
- ♣ *Ignores human welfare*
- ♣ *Income inequality*
- ♣ *Exploitation of labour*
- ♣ *Consumer sovereignty is myth*
- ♣ *Misallocation of resources ( for luxury goods)*
- ♣ *Less of merit goods (education and health)*
- ♣ *Unplanned production*
- ♣ *Enormous waste of productive resources*
- ♣ *Formation of monopolies*
- ♣ *Excessive materialism as well as conspicuous and unethical consumption.*

### SOCIALIST ECONOMY (eg: China, North Korea)

The concept of socialist economy was propounded by **Karl Marx and Frederic Engels** in their work '**the Communist Manifesto**' published in 1848. Socialist economy is also called as command economy or centrally planned economy.

### Characteristics:

- ♥ *Collective ownership*
- ♥ *Economic planning*
- ♥ *Absence of consumer choice*
- ♥ *Relatively equal income distribution*
- ♥ *Minimum role of price mechanism or market forces*
- ♥ *Absence of competition*

### Merits of Socialism

- ♦ *Equitable distribution of wealth and income*
- ♦ *Rapid and balanced economic development*
- ♦ *Better utilization of resources*
- ♦ *Unemployment is minimised*

## CHAPTER 1 - NATURE AND SCOPE OF BUSINESS ECONOMICS

---

- ◆ *Co-operative mentality*
- ◆ *Right to work and minimum standard of living*
- ◆ *Social security*

### Demerits of Socialism

- *Predominance of bureaucracy, corruption, red tapism*
- *Restrict freedom of individual*
- *Right to property not available*
- *Administered prices are not determined by market forces*
- *Does not provide incentive*
- *State monopolies*
- *Limited freedom of choice*

### MIXED ECONOMY (eg; India)

*Features of Mixed Economy (private, public, combined sector)*

*Merits are same as of capitalist and socialist economy*

### Demerits of Mixed Economy

- *Constrained growth of private sector*
- *Poor implementation of planning*
- *Higher rate of tax*
- *Lack of efficiency*
- *Corruption*
- *Wastage of resources*
- *Undue delay in economic decisions*
- *Poor performance of public sector*

UNIT 1 - LAW OF DEMAND AND ELASTICITY OF DEMAND

Meaning of Demand

- + *Desire*
- + *Means to purchase*
- + *Willingness to use those means for that purchase*
- + *Quantity demanded is expressed at a given price.*
- + *Quantity demanded is flow*

What determines demand?

- ❖ **Price of the commodity** ( P increases D decreases )
- ❖ **Price of related commodities** (substitute[ P increase tea and coffee D decrease] positive relation, complementary[ P increase pen and ink D increase] negative relation)
- ❖ **Disposal income of the consumer** { I increase Normal goods D increase positive relation, I increase Inferior goods D decreases negative relation}
- ❖ **Taste and preference of buyers**
  - **Demonstration effect** - people buy or have things because they see that other people are able to have them.
  - **Snob effect** - demand for a consumer's good is decreased owing to the fact that others are also consuming
  - **Veblen effect** - highly priced goods are consumed by status seeking rich people to satisfy their need for conspicuous consumption.
  - **Bandwagon effect** - demand for a commodity is increased due to the fact that others are also consuming the same commodity.
- ❖ **Consumer's expectations** { consumer expects increase in future prices, increases in income and shortage in supply, more quantities will be demanded and vice versa.
- ❖ **Other factors**
  - *Size of population*
  - *Age distribution of population*
  - *The level of national income and its distribution*
  - *Consumer credit facility and interest rates*
  - *Government policies and regulations*

Demand function

$$Q_x = f(P_x, Y, P_r)$$

The Law of Demand

Prof. Alfred Marshall defined the law thus: "The greater the amount to be sold, the smaller must be the price at which it is offered in order that it may find purchasers or in other words the amount demanded increases with a fall in price and diminishes with a rise in price".

Thus there is an inverse relationship between price and quantity demanded, *ceteris paribus*.

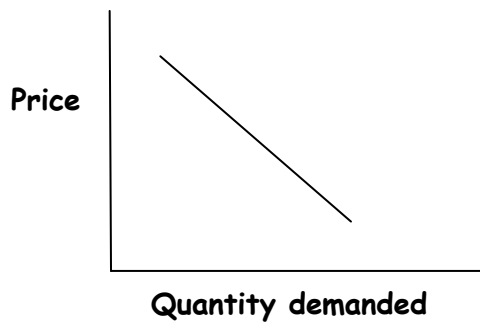

### The Demand Schedule

- ✓ **Individual demand schedule** - single buyer
- ✓ **Market demand schedule** - two or more buyers

### Rationale of the Law of Demand

- ✦ **Price effect of a fall in price** - already discussed above
  - Substitution effect
  - Income effect
- ✦ **Utility maximising behaviour of consumers** - with reduction in price, consumers will demand more commodity as the law of diminishing marginal utility concept applies.
- ✦ **Arrival of new consumers** - more consumers, more demand
- ✦ **Different uses** - more uses, more demand

### Exception to the Law of Demand ( P increases D increases )

- ◆ **Conspicuous goods** - prestigious goods
- ◆ **Giffen goods** - Sir Robert Giffen named some inferior goods as Giffen goods.
- ◆ **Conspicuous necessities** - necessities of life
- ◆ **Future expectations about prices**
- ◆ **Incomplete information and irrational judgement**
- ◆ **Demand for necessities**
- ◆ **Speculative goods**

### Expansion and Contraction of Demand/movement along the demand curve (due to change in price )

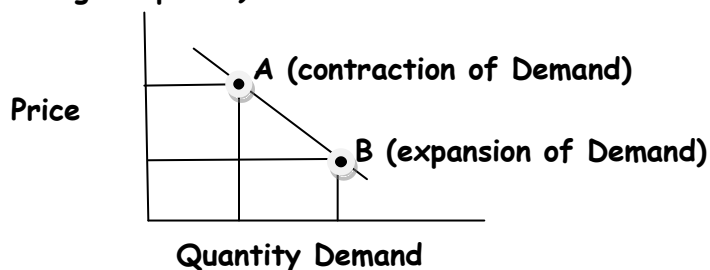

### Increase and decrease in Demand/shift in Demand curve (due to other determinants other than price)

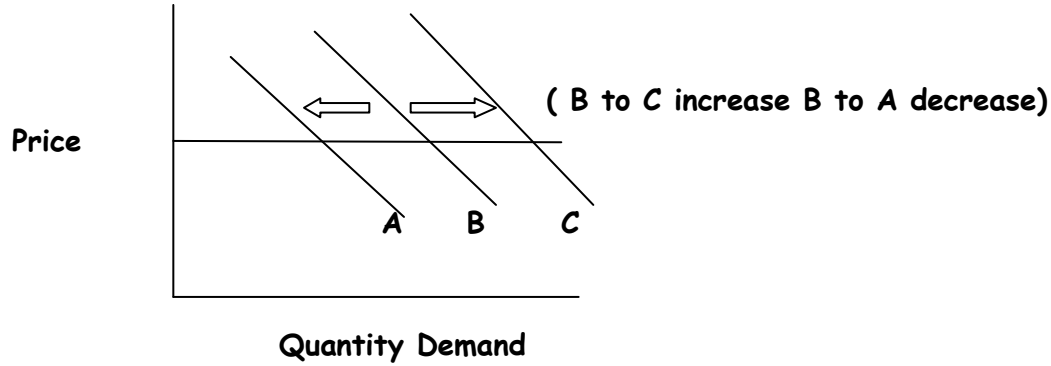

**Elasticity of Demand**

Elasticity of demand is defined as the responsiveness of the quantity demanded of a good to changes in one of the variables on which demand depends. More precisely, elasticity of demand is the percentage change in quantity demanded divided by the percentage change in one of the variables on which demand depends.

**Price Elasticity of Demand**

$$E_p = \frac{\% \text{change in Quantity Demanded}}{\% \text{ change in Price}}$$

$$E_p = \frac{\Delta q}{\Delta p} \times \frac{p}{q}$$

**Point elasticity**

The product of price quantity ratio at a particular point on the demand curve and the reciprocal of the slope of the demand curve

**Measurement of Elasticity on a Linear Demand Curve - Geometric Method**

$$= \frac{\text{lower segment}}{\text{Upper segment}}$$

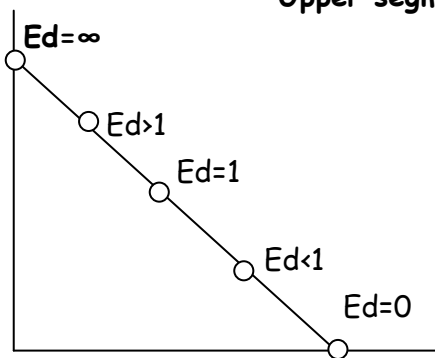

**Arc Elasticity**

$$E_p = \frac{Q_2 - Q_1}{Q_2 + Q_1} \times \frac{P_2 + P_1}{P_2 - P_1}$$

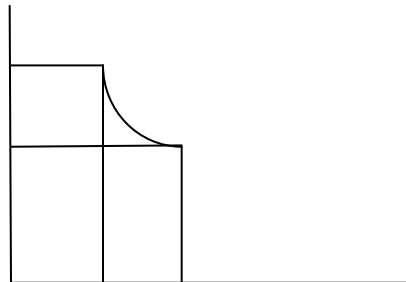



Interpretation of the numerical values of Elasticity of Demand

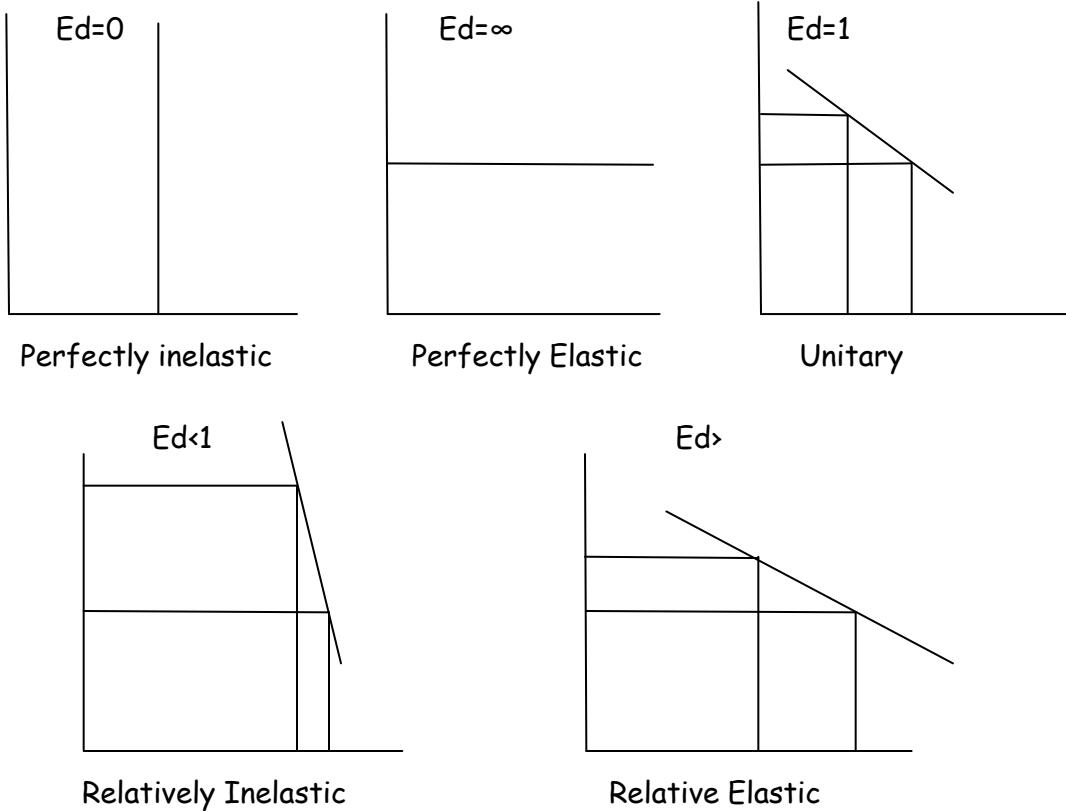

Total Outlay Method of Circulating Price Elasticity

- ✚  $Ed = 1$  -  $P$  increases and total revenue/total expenditure remains same
- ✚  $Ed > 1$  -  $P$  increases and total revenue/total expenditure falls
- ✚  $Ed < 1$  -  $P$  increases and total revenue/total expenditure increase

Total revenue (TR) =  $P \times Q$  sold

- Price effect:  $P$  increases  $R$  increases
- Quantity effect:  $P$  increases  $R$  decreases

Relationship between price elasticity and total revenue

Demand			
	Elastic	Unitary elastic	Inelastic
P increases	TR decreases	TR remains same	TR increases
P decreases	TR increases	TR remains same	TR decreases

Determinants of Price Elasticity of Demand

- ◆ Availability of substitute - more substitute elastic demand, no substitute inelastic
- ◆ Position of a commodity in the consumer budget - greater income spent more elastic and vice versa

- ◆ Nature of the need that a commodity satisfies - luxury goods elastic and necessities goods inelastic
- ◆ Number of uses to which a commodity can be put - more uses more elasticity and vice versa
- ◆ Time period - longer period elastic and short period inelastic
- ◆ Consumer habits - habit then inelastic and no habit elastic
- ◆ Tied demand - goods with very high or low range inelastic demand, middle range elastic demand
- ◆ Minor complementary goods - cheap goods with costlier goods demand is inelastic.

### Income elasticity of demand

$$E_i = \frac{\% \text{change in Quantity Demanded}}{\% \text{change in income}}$$

$$E_i = \frac{\Delta q}{\Delta y} \times \frac{y}{q}$$

### Relationship between income elasticity for a good and the proportion of income spent.

- ♣ Proportion of income spent on a good remains same as income increases, the income elasticity for that good is equal to one
- ♣ Proportion of income spent on a good increases as income increases, the income elasticity for that good is greater than one
- ♣ Proportion of income spent on a good decreases as income rises, the income elasticity for that good is positive but less than one.

Income elasticity is positive then its normal goods. If income elasticity is negative then its inferior goods.

### Cross price elasticity of demand

- ♥ Substitute product and demand - P increases (X) D increases (Y) upward (positive) sloping curve
- ♥ Complementary goods - P increases (X) D decreases (Y) downward (negative) sloping curve

$$E_c = \frac{\% \text{change in Quantity Demanded of X good}}{\% \text{change in price of Y good}}$$

$$E_c = \frac{\Delta Q_x}{\Delta P_y} \times \frac{P_y}{Q_x}$$

- ❖ Goods are perfect substitute, cross elasticity is infinite
- ❖ Goods are close substitute, cross elasticity will be positive and large
- ❖ Goods are not close substitute, cross elasticity will be positive and small
- ❖ Goods are totally unrelated, cross elasticity between them is zero

### Advertising elasticity

Advertising elasticity is positive

### Demand Forecasting

Forecasting of demand is the art and science of predicting the probable demand for a product or a service at some future date on the basis of certain past behaviour patterns of some related events and the prevailing trends at present.

### Type of forecasts

- ✓ *Macro-level forecasting deals with the general economic environment*
- ✓ *Industry-level forecasting is concerned with the demand for the industry's product as a whole*
- ✓ *Firm-level forecasting refers to forecasting the demand for a particular firm's product*

### Basis on time period

- *Short term demand - 6 to 12m*
- *Long term forecasting - 1 to 5 y*

### Demand distinctions

- ✚ *Producer's goods - for production*
- ✚ *Consumer goods - final consumption*
- ✚ *Durable goods - consumed over a long period of time*
- ✚ *Non-durable goods - cannot be consumed more than once*
- ✚ *Derived demand - demand arises bcoz demand for some other commodity*
- ✚ *Autonomous demand - if the demand for a product is independent of the demand for other good*
- ✚ *Industry demand - total demand for the product of a particular industry*
- ✚ *Demand for firm's product - demand for the products of a particular firm*
- ✚ *Short run demand - demand with its immediate reaction to changes*
- ✚ *Long run demand - demand which exist over a long period*

### Factors affecting demand for Non-durable consumer goods

- ♣ *Disposal income*
- ♣ *Price*
- ♣ *Demography*

### Factors affecting demand for Durable consumer goods

- ◆ *Postpone*
- ◆ *Special facilities for their use*
- ◆ *Used by more than one person*
- ◆ *Replacement demand*
- ◆ *Prices and credit facilities*

### Factors affecting demand for Producer goods

- ♣ *Growth prospects*
- ♣ *Norms of consumption*

**Method of demand forecasting**

❖ **Survey of buyers intentions**

- Complete enumeration
- Sample survey method
- End use method

❖ **Collective opinion method/sales force opinion/grass roots approach**

❖ **Expert opinion method** - the Delphi technique, developed by Olaf Helmer, provides a useful way to obtain informed judgments from diverse experts.

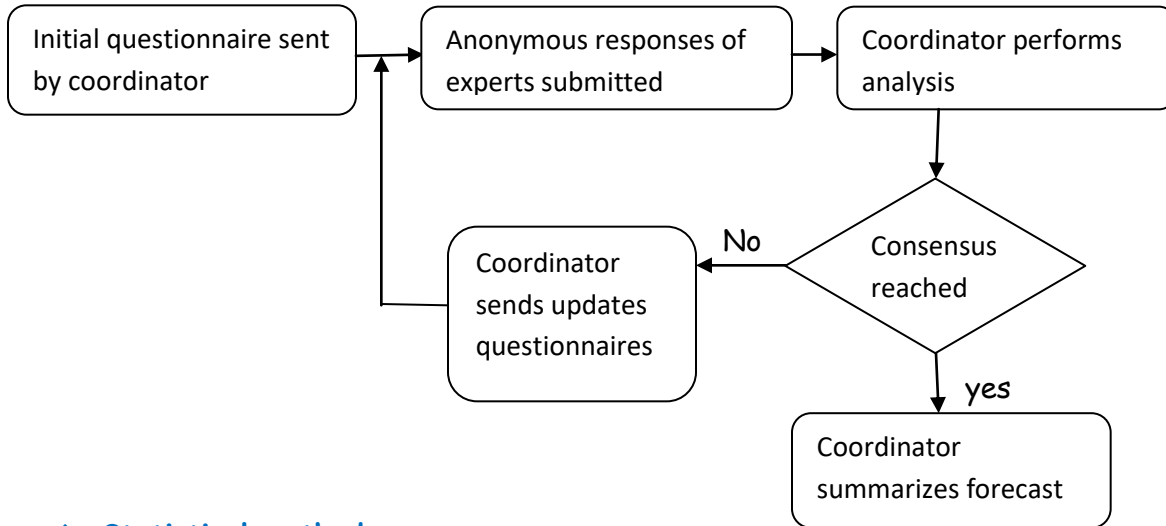

❖ **Statistical methods**

✚ **Trend projection method/classical method** - is considered as a naïve approach to demand forecasting.

- Graphical method
- Fitting trend equation

✚ **Regression analysis**

❖ **Controlled experiments**

❖ **Barometric method of forecasting**

**UNIT 2 - THEORY OF CONSUMER BEHAVIOUR**

**Nature of Human Wants**

- ✦ Wants refers to wish, desire or motive
- ✦ Wants are unlimited
- ✦ Wants differ in intensity
- ✦ Wants is satiable
- ✦ Wants are competitive
- ✦ Wants are complementary
- ✦ Wants are subjective and relative
- ✦ Wants vary with time, place, and person
- ✦ Wants may become habits and customs
- ✦ Wants are affected by income, taste, fashion
- ✦ Wants arise from multiple causes

**Classification of wants**

- **Necessaries** - essential for living
- **Comforts** - makes life comfortable and satisfying
- **Luxuries** - which are superfluous and expensive

**Utility**

- Utility is thus the want satisfying power of a commodity.
- Utility is subjective and relative entity.
- *Marginal utility analysis* propounded by Alfred Marshall
- *Indifference curve analysis* propounded by J.R Hicks and R.G.D Allen

**The Marginal Utility Analysis**

- ♣ It is a quantitative measure
- ♣ Utility is the numerical score in terms of *utils*
- ♣ *Total utility* - as the sum of utility derived from different units of a commodity consumed by a consumer
- ♣ *Marginal utility* - it is the utility derived from the marginal or one additional unit consumed or possessed by the individual
- ♣  $MU_n = TU_n - TU_{n-1}$

**Assumption of marginal utility analysis**

- ♥ *Rationality (samjhdar)*
- ♥ *Cardinal measurement of utility - no ke terms main*
- ♥ *Money is the measuring rod of utility*
- ♥ *Theory assumes all the other factors constant*
- ♥ *Continuity in consumption*
- ♥ *Units are homogenous or identical in nature*
- ♥ *Standard units*
- ♥ *Marginal utility of money remains constant*

- ♥ *Independent utility*
- ♥ *Ignores complementarity between goods.*

### The Law of Diminishing Marginal Utility

As consumer increases the consumption of any one commodity keeping constant the consumption of all other commodity, the marginal utility of the variable commodity must eventually decline.

- ♣ *TU rises as long as MU positive but at diminishing rate*
- ♣ *MU diminishes*
- ♣ *MU is zero TU is maximum (saturation point)*
- ♣ *MU is negative, TU is diminishing*

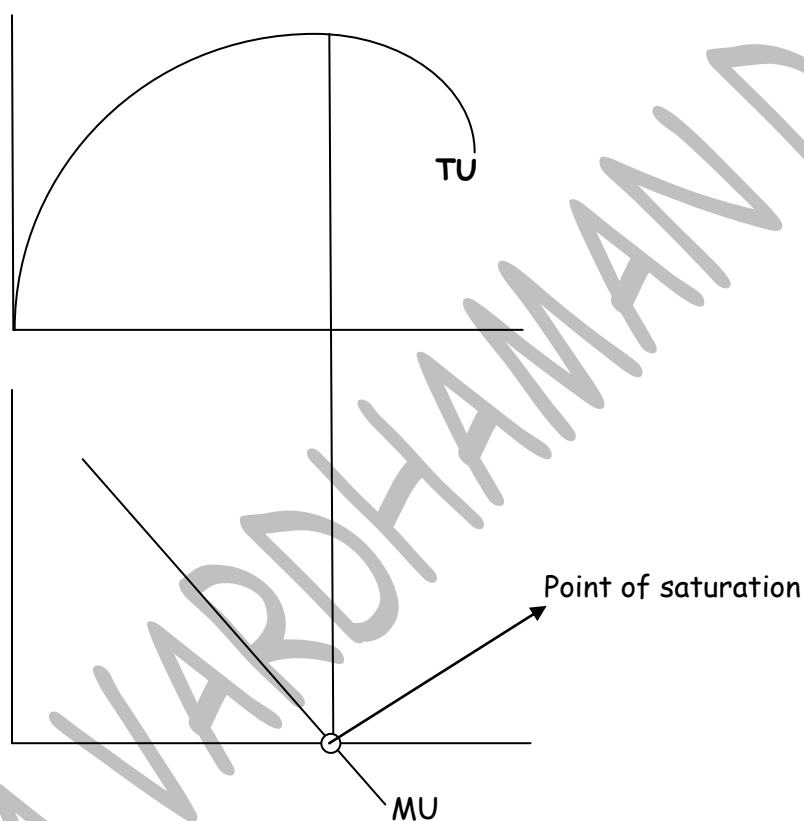

### Limitation and Exceptions of the Law of Diminishing Marginal Utility

- ◆ *Rigorous assumption*
- ◆ *Not independent*
- ◆ *Law is not universal*
- ◆ *Prestigious goods*
- ◆ *Hobbies, rare collection, creative art, painting, music, poetry etc*
- ◆ *In case of habit*
- ◆ *People with miserly behavior*

Consumer equilibrium in single commodity case

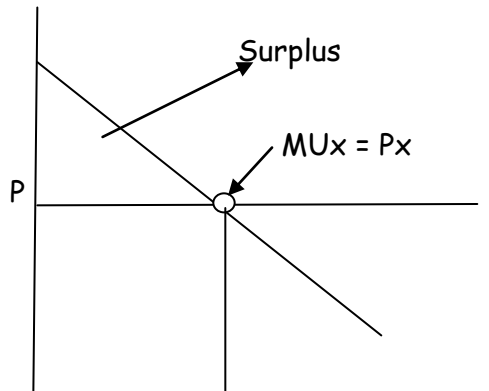

$$\frac{MU_x = MU_m}{P_x}$$

Consumer equilibrium in two commodity case (Equi-Marginal Utility)

$$\frac{MU_x}{P_x} = \frac{MU_y}{P_y} = \frac{MU_m}{M}$$

Consumer surplus

Marshall defined the concept of consumer surplus as the "excess of the price which a consumer would be willing to pay rather than go without a thing over that which he actually does pay", is called consumer surplus.

Applications

- ✦ Consumer surplus is a measure of the welfare that people gain from consuming goods and services
- ✦ Helps in setting price
- ✦ Large scale investment decision involve cost benefit analysis which takes into account the extent of consumer surplus
- ✦ For raising price
- ✦ Guide to finance ministry

Limitations

- Cannot be measured precisely
- In case of necessities, consumer surplus is infinite
- Consumer surplus is affected by availability of substitute
- No simple rule for deriving the utility scale
- Consumer surplus cannot be measured in terms of money
- Concept can be accepted only if it is assumed that utility can be measured in terms of money or otherwise.

Indifference curve

Assumption underlying indifference curve approach

- Consumer knows his taste and preference
- Consumer is rational

- Ordinal concept
- Consumer choices are assumed to be transitive
- More is better assumption or the assumption of non-satiation

### Indifference curves

- ♣ Is a curve which represents all those combination of two goods which give same satisfaction to the consumer
- ♣ It is also called as iso-utility curve or equal utility curve
- ♣ A set of indifference curve is known as indifference map

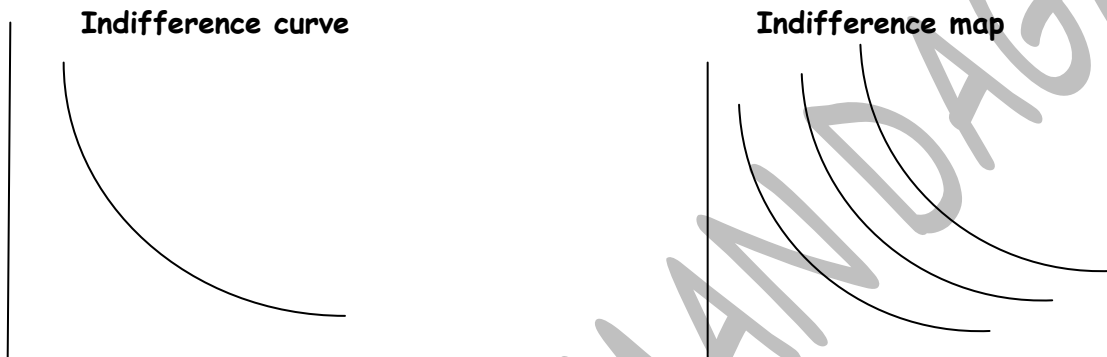

### Marginal rate of Substitution (MRS)

- ♥ Is the rate at which a consumer is prepared to exchange goods X and Y, holding the level of satisfaction constant (i.e moving along the indifference curve)
- ♥ MRS is falling bcoz consumer want to gain more and sacrifice less.  
Two reasons for this -
  - ♣ Want for a particular good is satiable so that when a consumer has more of it, his intensity of want for it decreases.
  - ♣ Most goods are imperfect substitute of one another. If perfect substitute the MRS will be constant.

### Properties of Indifference Curve

- ✚ Indifference curves slopes downward to the right - bcoz ek ko sacrifice toh dusare ko gain
- ✚ Indifference curves are always convex to origin - due to falling MRS
- ✚ Indifference curve will be L shaped if two goods are perfect complementary.
- ✚ Indifference curve can never intersect each other - as higher and lower level are equal
- ✚ A higher indifference curve represents a higher level of satisfaction that the lower indifference curve
- ✚ Indifference curve will not touch either axes - as it is combination of two goods.



**Budget line**

Budget line shows all the *combination of two goods* which the consumer can buy spending his given money *income* on the two goods at their given prices.

$$P_x Q_x + P_y Q_y = B \text{ (income)}$$

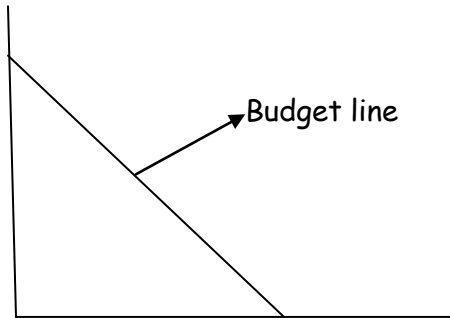

Budget line shift due to change in income and price of the goods.

**Consumer equilibrium**

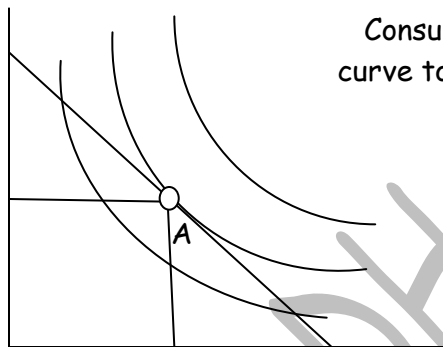

Consumer is in equilibrium at the point where indifference curve touches the budget line

$$MRS_{xy} = \frac{P_x}{P_y}$$

**Assumptions:-**

- ❖ *Combination of two goods*
- ❖ *Fixed income to spent on two goods*
- ❖ *Prices of goods are fixed*
- ❖ *Goods are homogenous and divisible*
- ❖ *Consumer acts rationally and maximize his satisfaction*

**UNIT 3 - SUPPLY**

Supply refers to the amount of a good or service that the producers are *willing and able to offer* to the market at *various prices* during a *given period of time*.

Determinants of supply

- ♣ **Price of the good** - P increases S increases
- ♣ **Prices of the related goods** - P increases of related goods S increases of it
- ♣ **Prices of factors of production** - Cost increases S decreases
- ♣ **State of technology** - new technology S increases
- ♣ **Government policy** - taxes increases S decreases subsidy increases S increases
- ♣ **Nature of competition and size of industry** - competitive S increases
- ♣ **Expectations** - future price increase S decreases currently
- ♣ **Number of sellers** - more firms more S
- ♣ **Other factors** - govt. policies, natural factors etc.

The Law of Supply

Other things remain constant, P increases S increases and vice versa (positive relation)

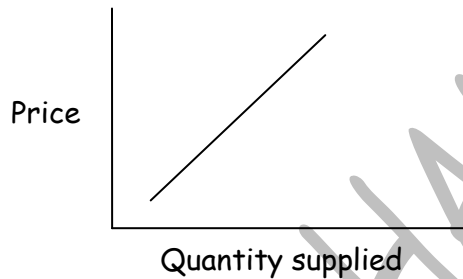

Movements on the supply curve - increase or decrease in the quantity supplied ( due to price)

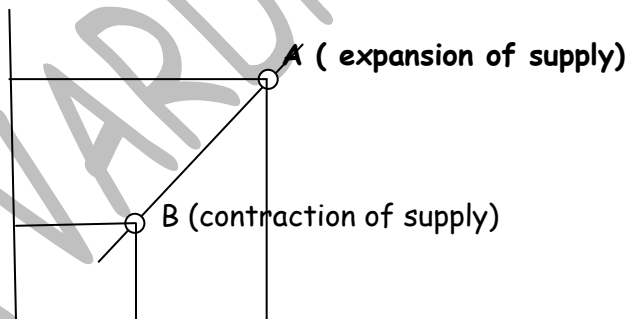

Shift in supply curve - increase or decrease in supply (due to change in other factors other than price)

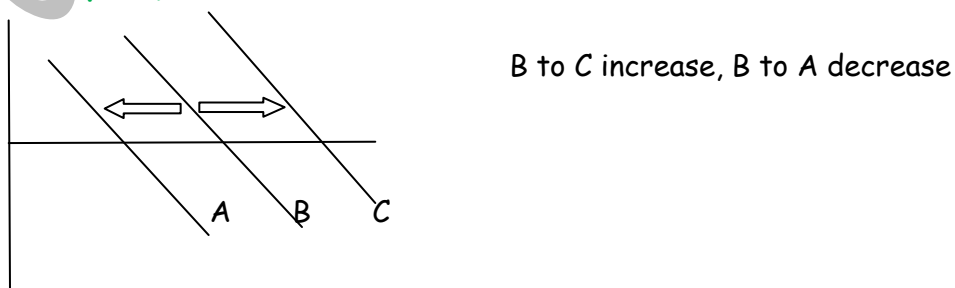

## CHAPTER 2 - THEORY OF DEMAND AND SUPPLY

### Elasticity of supply

As the responsiveness of the quantity supplied of a good to a change in price.

$$E_s = \frac{\% \text{change in Quantity Supplied}}{\% \text{change in Price}}$$

$$E_s = \frac{\Delta q}{\Delta p} \times \frac{p}{q}$$

### Types of supply elasticity

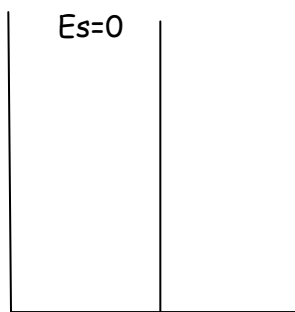

Perfectly inelastic

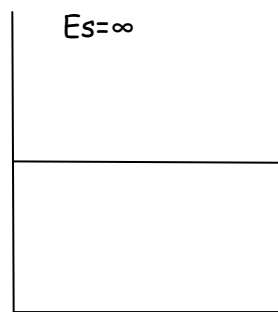

Perfectly Elastic

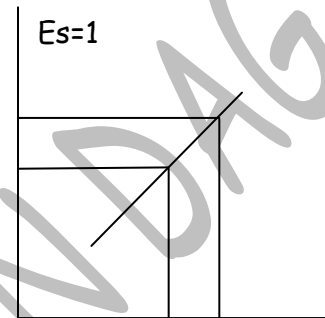

Unitary

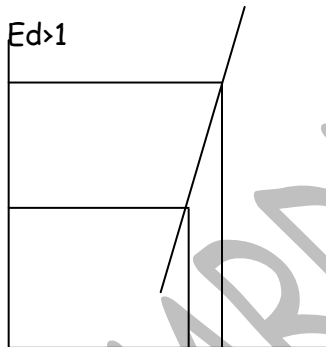

Relatively elastic

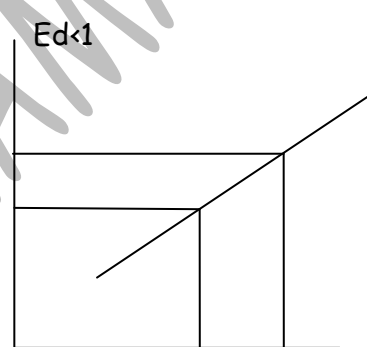

Relative InElastic

### Arc elasticity

$$E_p = \frac{Q_2 - Q_1}{Q_2 + Q_1} \times \frac{P_2 + P_1}{P_2 - P_1}$$

### Determinants of elasticity of supply

- ✦ Cost increases S is inelastic and vice versa
- ✦ Long period supply is elastic and vice versa
- ✦ Large number of producers supply is elastic and vice versa
- ✦ Unutilized capacity is there supply is elastic and vice versa
- ✦ Raw material and inputs cheaper supply is elastic and vice versa
- ✦ Adequate stocks of raw material etc supply will be elastic and vice versa

## CHAPTER 2 - THEORY OF DEMAND AND SUPPLY

- ✦ **Factor of production** commonly available and can easily be substituted or increased then supply is elastic and vice versa
- ✦ **Capital and labour are occupationally** mobile then supply is elastic and vice versa
- ✦ **Expectation of substantial rise in price** supply would be inelastic and vice versa

### Equilibrium price

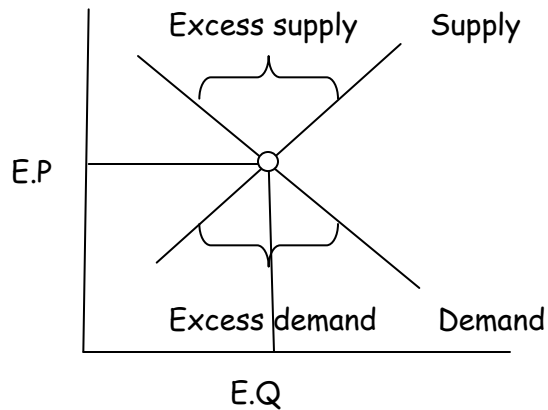

### Market equilibrium and social efficiency

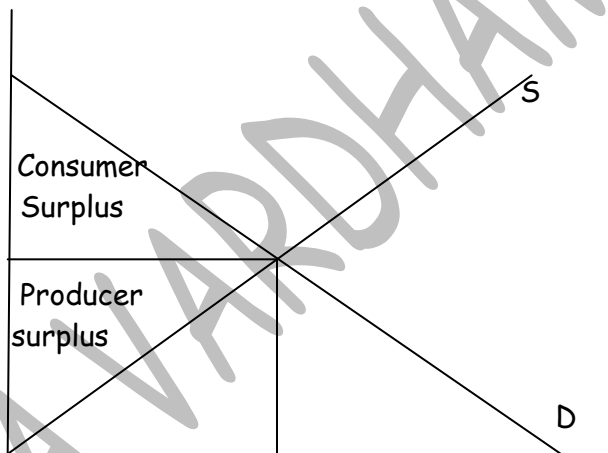

UNIT 1 - THEORY OF PRODUCTION

Production is the organized activity of transforming resources into finished products in the form of goods and services; and the objective of production is to satisfy the demand of such transformed resources.

✚ **Creation of utility**

✚ Any economic activity which converts inputs into output which are capable of satisfying human wants.

✚ **Form utility** - raw material to finished goods

✚ **Place utility** - one place to one another

✚ **Time utility** - jab goods ki need ho available karwana

Factors of production

Land

Characteristics:-

- ♣ Land is *free gift of nature*
- ♣ Supply of land is fixed - *perfectly inelastic*
- ♣ Land is *permanent and has indestructible powers*
- ♣ Land is *passive factor*
- ♣ Land is *immobile*
- ♣ Land has *multiple uses*
- ♣ Land is *heterogeneous* - not same

Labour

Means any physical or mental exertion directed to produce goods or services.

Characteristics of labour:-

- ♥ *Human efforts*
- ♥ Labour is *perishable*
- ♥ Labour is an *active factor*
- ♥ Labour is *inseparable* from the labourer
- ♥ Land *power differs* from labourer to labourer
- ♥ All labour *may not be productive*
- ♥ Labour has *poor bargaining power*
- ♥ Labour is *mobile*
- ♥ There is *no rapid adjustment of supply* of labour to the demand for it
- ♥ *Choice between hours of labour and hours of leisure(rest)*

Capital

Rightly defined as 'produced means of production' or 'man-made instrument of production'. Capital refers to all man made goods that are used for further production of wealth.

Types of capital:

- ◆ **Fixed capital** - which exist in durable shape eg. Machines

## CHAPTER 3 - THEORY OF PRODUCTION AND COST

---

- ◆ **Circulating capital** - single use eg. Raw material
- ◆ **Real capital** - physical goods eg. Plant
- ◆ **Human capital** - human skill and ability
- ◆ **Tangible capital** - can be perceived by senses
- ◆ **Intangible capital** - cannot be perceived by senses in form of rights and benefits
- ◆ **Individual capital** - personal property
- ◆ **Social capital** - belong to society eg. Roads

### Capital formation

Capital formation means a sustained increase in the stock of real capital in a country. (eg. Capital goods)

### Stages of capital formation

- ♣ *Savings*
- ♣ *Mobilisation of savings*
- ♣ *Investment*

### Entrepreneur

#### Functions of entrepreneur

- *Initiating business enterprise and resource co-ordination*
- *Risk bearing and uncertainty bearings*
- *Innovations*

### Enterprise's objectives and constraints

#### Objectives of an enterprise

- **Organic objectives** - survive and growth
- **Economic objectives** - profit ( accounting profit = total revenue - total cost (explicit cost) and economic profit = total revenue - total cost (explicit and implicit cost)
  - ✓ **H A simon** argues that firms have 'satisfying' behaviour and strive for profits that are satisfactory
  - ✓ **Baumol's theory** of sales maximization holds that sales revenue maximization rather than profit maximization is the ultimate goal of the business firms.
  - ✓ **A.A Berle and G.C.** means pointed out that in large business corporations, management is separated from ownership and therefore the managers enjoy discretionary powers to set goals of the firm they manage.
  - ✓ **Williamson's model** of maximization of managerial utility function is an important contribution to managerial theory of firm's behaviour.

## CHAPTER 3 - THEORY OF PRODUCTION AND COST

---

- ✓ **Cyert and March** suggests four possible functional goals in addition to profit goal namely, production goal, inventory goal, sales goal and market share goal.
- **Social objective** - related to society
  - ❖ Continuous and sufficient supply of goods
  - ❖ Avoid profiteering and anti-social practices
  - ❖ Create employment
  - ❖ Does not cause pollution
  - ❖ Improving quality of life
- **Human objective** - related to human and employee
  - Fair deal to employee
  - Develop new skills and ability
  - Provide employee to participate in decision making
  - Make job interesting and challenging
- **National objectives** - towards nation
  - ✚ Remove inequalities of opportunities
  - ✚ Produce according to national priorities
  - ✚ Country become self-reliant and avoid dependence
  - ✚ Train young man as apprentices

In the pursuit of this objective, an enterprise's actions may get Constrained by many factors

- ♣ Lack of knowledge and information
- ♣ Restrictions imposed in public interest by the state on the production, price and movement of factors.
- ♣ Infrastructure inadequacies and consequent supply chain bottlenecks
- ♣ Changes in business and economic conditions
- ♣ Events such as inflation, rising interest rates, unfavourable exchange rate fluctuations

### Enterprise problems

- ♥ Problem relating to *objectives*
- ♥ Problem relating to *location and size of the plant*
- ♥ Problem relating to *selecting and organising physical facilities*
- ♥ Problem relating to *finance*
- ♥ Problem relating to *organisational structure*
- ♥ Problem relating to *marketing (4p's)*
- ♥ Problem relating to *legal formalities*
- ♥ Problem relating to *industrial relations*

### Production function

The relationship between the maximum amount of output that can be produced and the input required to make that output. It is defined for a given state of technology

i.e., the maximum amount of output that can be produced with given quantities of inputs under a given state of technical knowledge. (samuelson) L=labour K=capital

### Assumptions -

- ✦ Relationship between input and output exists for a specific period of time
- ✦ There is given "state-of-the-art" in the production technology
- ✦ Whatever input combinations are included in a particular function, the output resulting from their utilization is at maximum level

**Short-Run** - if the amount of at least one of the inputs used remains unchanged during that period.

**Long-Run** - is a period of time (or planning horizon) in which all factors of production are variable.

### Cob-Douglas Production Function

Where Q is output and L the quantity of labour and C the quantity of capital K and a are positive constraints

The conclusion drawn from the famous statistical study is that labour contributed about 3/4<sup>th</sup> and capital about 1/4<sup>th</sup> of the increase in the manufacturing production. It is used in economics as an approximation

### Law of variable proportions or the law of diminishing returns

The law states that as we increase the quantity of one input which is combined with other fixed input, the marginal physical productivity of the variable input must eventually decline.

**Total product (TP)** - TP is the total output resulting from the efforts of all factors of production combined together at any time.

**Average product (AP)** - AP is the total product per unit of the variable factor.

$$AP = TP/Q$$

**Marginal product (MP)** - MP is the change in total product per unit change in quantity of variable factor.

$$MP_n = TP_n - TP_{n-1}$$

### Relationship between AP and MP

- AP rises as a result of an increase in the quantity of variable input, MP is more than AP
- MP cuts the AP at its maximum
- When AP falls, MP is below AP



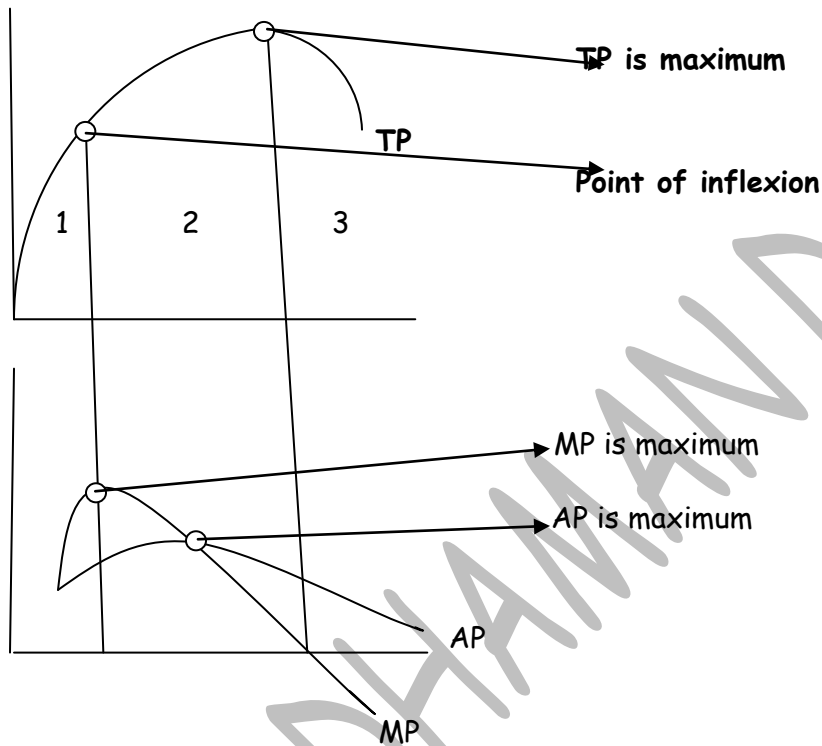

**Stage 1: The stage of increasing returns**

- ♣ Better utilization of fixed factor
- ♣ Division of labour and increase in efficiency
- ♣ Better co-ordination between factors

**Stage 2: The stage of Diminishing returns**

- ♥ Fixity of a factor
- ♥ Imperfect factor substitutability
- ♥ Poor co-ordination between factors

**Stage 3: The stage of negative returns**

- ♦ Excessive variable factor

**Stage of operation - stage 2**

**Return to scale**

Changes in output when all factors of production in a particular function are increased together.

## CHAPTER 3 - THEORY OF PRODUCTION AND COST

**Constant return to scale** - increase in scale in same proportion, output increases in the same proportion. (eg. 10% - 10% )

**Increasing return to scale** - output increases in a greater proportion than the increase in inputs (eg. 10% - 20%)

**Decreasing return to scale** - output increases in smaller proportion relative to an increase in all inputs (eg. 10% - 5%)

### Production optimisation

- ♣ **Isoquants** similar to indifference curve
- ♣ All those combinations of inputs which are capable of producing the same level of output.
- ♣ Isoquants are also called equal-product curves, production indifference curve or iso-product curves
- ♣ Isoquants are convex due to diminishing marginal rate of technical substitution (MRTS)
- ♣ **Iso cost** or equal-cost lines similar to budget line
- ♣ Iso cost is a combination of two factors, which the firm can buy with a given outlay.

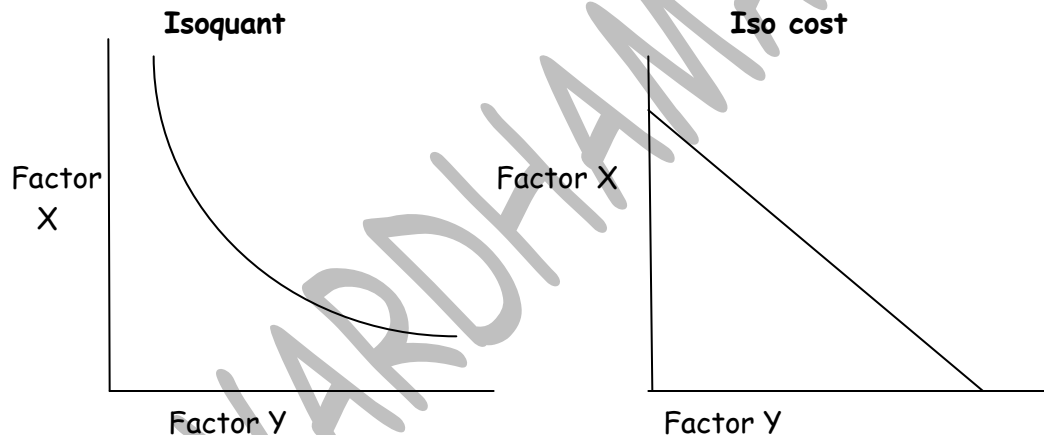

### Least-cost combination of factors: Producer's Equilibrium

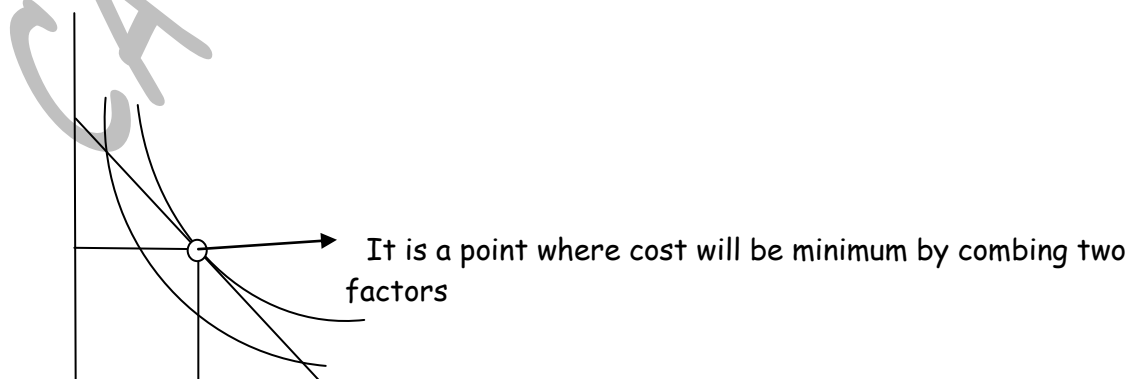

UNIT 2 - THEORY OF COST

Cost concepts

Accounting cost

- ❖ Which involve cash payment by the entrepreneur
- ❖ These are explicit cost

Economic cost

- ✚ Monetary payments of all factors owned by the entrepreneur himself in his own business
- ✚ Normal return on money capital invested by the entrepreneur himself in his business
- ✚ Wages or salary not paid to the entrepreneur, but could have earned if the services has been sold somewhere else.

Outlay cost

- ♣ Actual expenditure of funds on say wages, materials, rent, interest, etc

Opportunity cost

- Cost of next best alternative opportunity which has foregone in order to pursue a certain action

Direct or traceable costs

- ❖ Are those which have direct relationship with a component operation like manufacturing a product, organizing a process or an activity etc.

Indirect cost or Non-traceable cost

- Are those which are not easily and definitely identifiable in relation to a plant, product, process or department.

Incremental cost

- ♠ Refers to the additional cost incurred by a firm as result of a business decision

Sunk cost

- ♥ Refers to those cost which are already incurred once and for all and cannot be recovered

Historical costs

- Refers to the cost incurred in the past on the acquisition of a productive asset such as machinery, building etc

Replacement costs

- ◆ Money expenditure that has to be incurred for replacing an old asset

Private costs

- Cost actually incurred or provided for by firms and are either explicit or implicit

Social costs

- Refers to the total cost borne by the society on account of a business activity and include private cost and external cost

## CHAPTER 2 - THEORY OF PRODUCTION AND COST

### Fixed cost

- ◆ Fixed cost or constant costs are not a function of output, they do not vary with output upto a certain level of activity

### Variable cost

- ✦ Cost that are a function of output in the production period

### Shutdown cost

- ✦ Some cost which will continue even after the operation are suspended eg. Storing of old machines which cannot be sold in the market.

**Cost function** - refers to the mathematical relation between cost of a product and the various determinants of costs.

**Short run** - is a period of time in which output can be increased or decreased by change only the amount of variable factors.

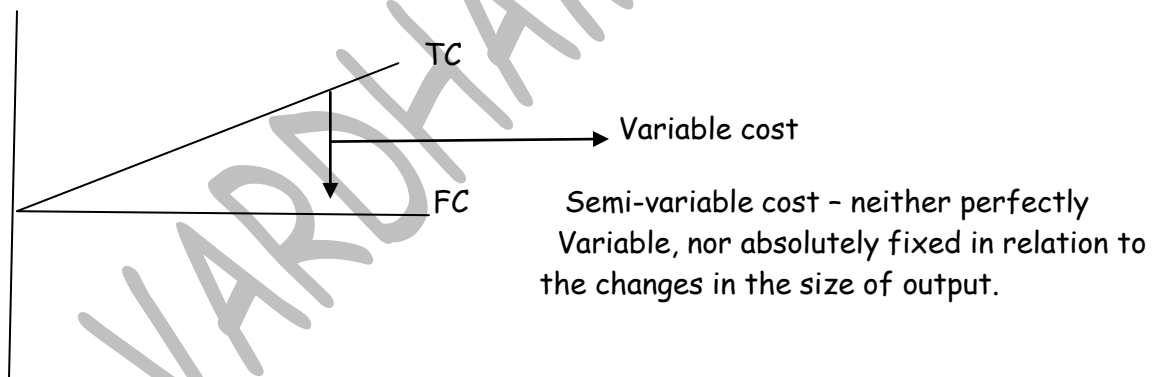
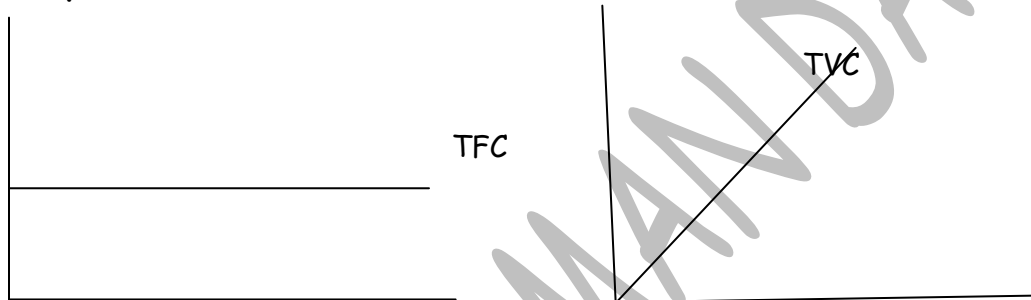

**Stair-step variable cost** - they remain fixed over certain range of output; but suddenly jump to a higher level when output goes beyond a certain limit.

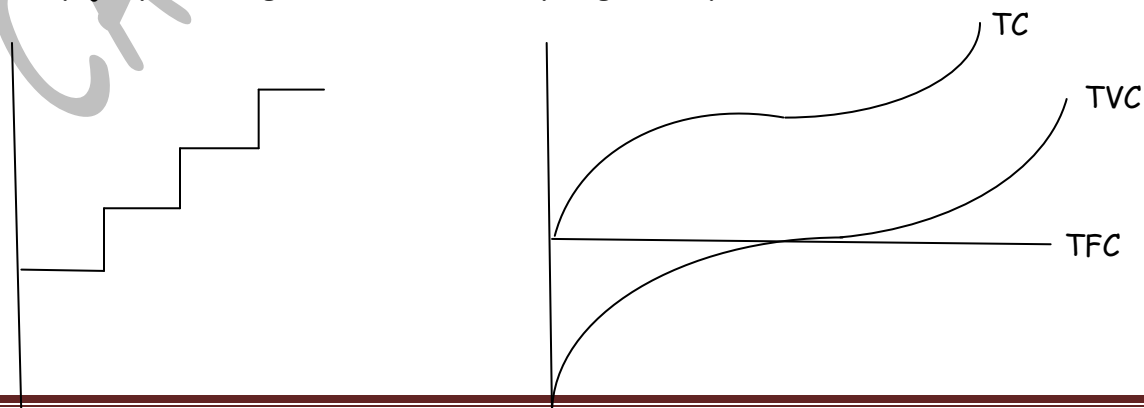

## CHAPTER 2 - THEORY OF PRODUCTION AND COST

Stair-step variable cost

$$TC = TVC + TFC$$

*TC and TVC both are S shaped due to law of variable proportion (LVP) applies. In the increasing stage of LVP our TP and MP both increases at increasing rate and our TC and TVC increases at diminishing rate. At the diminishing stage of LVP our TP increases at diminishing rate and MP decreases and our TC and TVC increases at increasing rate.*

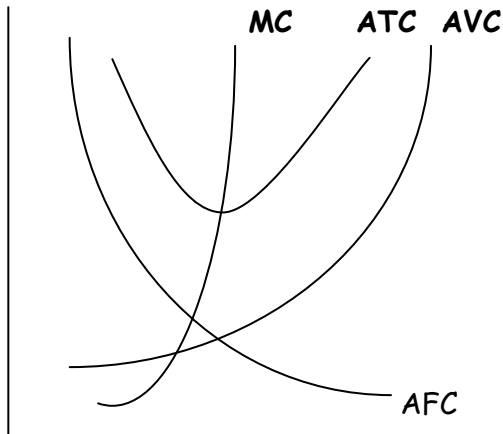

*AVC and ATC both are U shaped due to LVP applies. In the increasing stage of LVP our AVC and ATC both decreases. At the end of the increasing stage our AVC and ATC are minimum. In the diminishing stage of LVP our AVC and ATC both increases.*

*MC is U shaped as at the increasing stage our MP increases and MC decreases. At the end of the first stage MP is maximum and MC is minimum. At the second stage MP starts declining and MC start rising. (marginal hamesa average ko bolega agar gira toh there se teji se and bada toh tere se teji se)*

*The point were MC cuts AC, there the cost is minimum for producer. MC, TVC ke change se nikalta hai*

### Long run average cost curve

- ✚ Long run is a period of time during which the firm can vary all its inputs.
- ✚ Short run average cost curves (SACs) are called 'plant curve'.
- ✚ Long run average cost curve (LACs) is **not tangent** to the minimum points of the SAC curves.
- ✚ LAC is tangent to the falling and rising portion of the SAC.
- ✚ LAC is often called as 'planning curve' or envelope curve.
- ✚ LAC is U shaped due to economies and diseconomies of scale.
- ✚ L-shaped long run cost curve implies that initially when the output is increased due to increase in size of the plant, per unit cost falls rapidly due to economies of scale.

Economies and diseconomies of scale

Internal economies and diseconomies

- ♣ Technical economies and diseconomies
- ♣ Managerial economies and diseconomies
- ♣ Commercial economies and diseconomies
- ♣ Financial economies and diseconomies
- ♣ Risk bearing economies and diseconomies

External economies and diseconomies

- ❖ Change raw material and capital equipment
- ❖ Technology external economies
- ❖ Development of skilled labour
- ❖ Growth of ancillary industries
- ❖ Better transportation and marketing facilities
- ❖ Economies of information

## CHAPTER 4 - PRICE DETERMINATION IN DIFFERENT MARKETS

---

### UNIT - MEANING AND TYPES OF MARKETS

- ✚ Price signifies the quantity of money necessary to acquire a good or service.
- ✚ Value in exchange or exchange value, according to Ricardo, means command over commodities in general, or power in exchange over purchasable commodities in general.
- ✚ Value in use refers to usefulness or utility i.e the attributable which a thing may have to satisfy human needs.
- ✚ Value in exchange or economic value is the amount of goods or services which we may obtain in the market in exchange of a particular thing.
- ✚ The elements of a market are -
  - Buyers and sellers
  - A product or service
  - Bargaining for a price
  - Knowledge about market conditions; and
  - One price for a product or service at a given time.

#### Classification of market

##### On the basis of geographical area

- ♣ Local markets - buyers and sellers limited to a local area or region. Highly perishable goods and bulky articles
- ♣ Regional markets - covers a wide area such as a few adjacent cities, parts of states, or cluster of states.
- ♣ National market - demand for a commodity or service is limited to the national boundaries of a country. Eg; hindi books
- ♣ International market - commodity is said to have international market when it is exchanged internationally. Eg gold

##### On the basis of time

- ♣ Very short period market - eg. Vegetables
- ♣ Short period market - output can be increased from variable factor and fixed factor remains constant
- ♣ Long period market - all factors are variable
- ♣ Very long period or secular period - is one when secular movements are recorded in certain factors over a period of time

##### On the basis of nature of transaction

- ♦ Spot or cash market - either immediately or within a short span of time.
- ♦ Forward or future market - promised to pay and delivery goods at future date

##### On the basis of regulation

- ❖ Regulated market - statutorily regulated
- ❖ Unregulated market - free market

## CHAPTER 4 - PRICE DETERMINATION IN DIFFERENT MARKETS

### On the basis of volume of market

- Wholesale market - large quantities
- Retail market - small quantities

### On the basis of competition

- a) Perfect competition b) imperfectly competitive

### Types of market structures

Assumptions	Market types			
	Perfect competition	Monopolistic competition	Oligopoly	Monopoly
Number of sellers	Very large	Large	Small numbers	One
Product differentiation	None	Slight	None to substantial	Extremen
Price elasticity of demand of a firm	Infinite	Large	Small	Small
Degree of control over price	None	Some	Some	Very considerable

### Concept of total revenue, average revenue and marginal revenue

- **Total revenue** - sum total of money.  $TR = P \cdot Q$
- **Average revenue** - revenue earned per unit of output.  $AR = TR/Q$
- **Marginal revenue** - change in the total revenue resulting from the sale of an additional unit of commodity.  $MR = TR_n - TR_{n-1}$

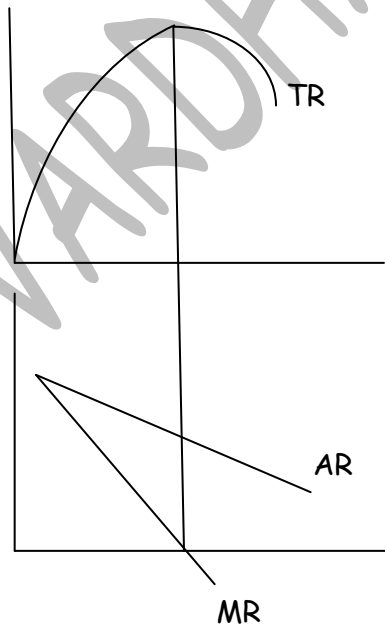



## CHAPTER 4 - PRICE DETERMINATION IN DIFFERENT MARKETS

At starting our TR increases at Diminishing rate and MR and AR decreases, when TR reaches at its highest point our MR is zero and AR is also decreasing. TR start decreasing, MR is negative and AR is still decreasing.

### Relationship between AR,MR,TR and price elasticity of demand

$$MR = AR * \frac{e-1}{e}$$

$$e = 1, MR = 0$$

$$e > 1 \text{ MR positive}$$

$$e < 1 \text{ MR negative}$$

AR curve is also known as demand curve

### Behavioural principles

**Principle 1** - a firm should not produce at all if its total variable costs are not meet.

**Principle 2** - The firm will be making maximum profits by expanding output to the level where marginal revenue is equal to marginal cost. (  $MC = MR$ ,  $MC$  must be rising,  $AR > AVC$  )

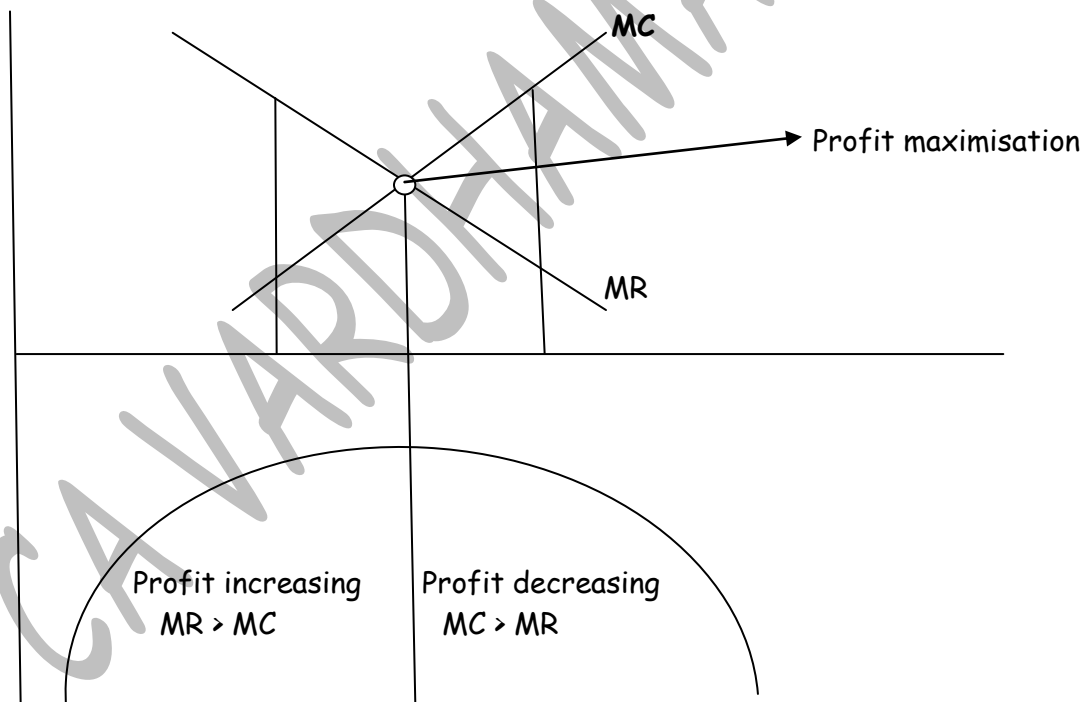

**UNIT 2 - DETERMINATION OF PRICES**

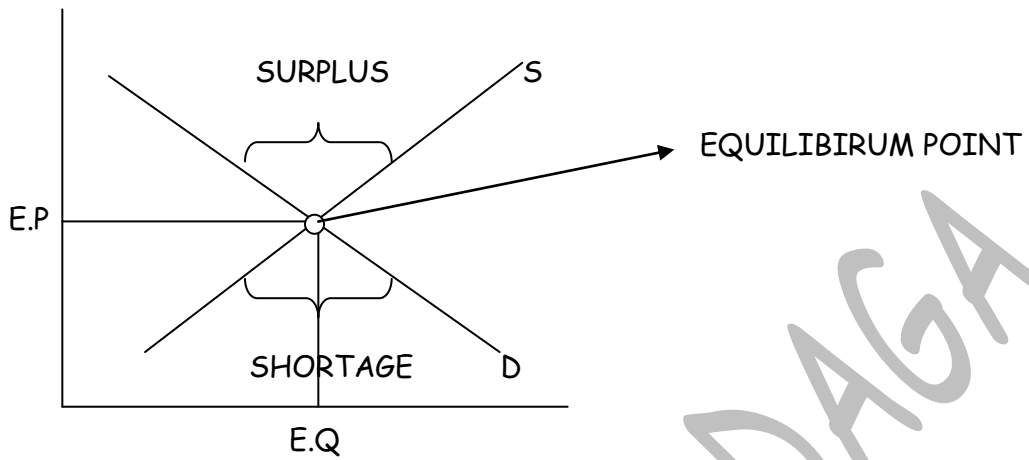

Change in Demand and Supply

Increase/decrease in demand

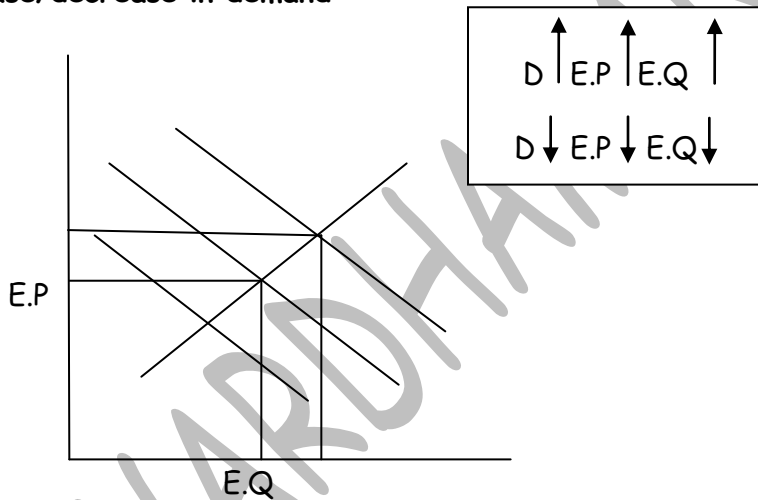

Increase/decrease in supply

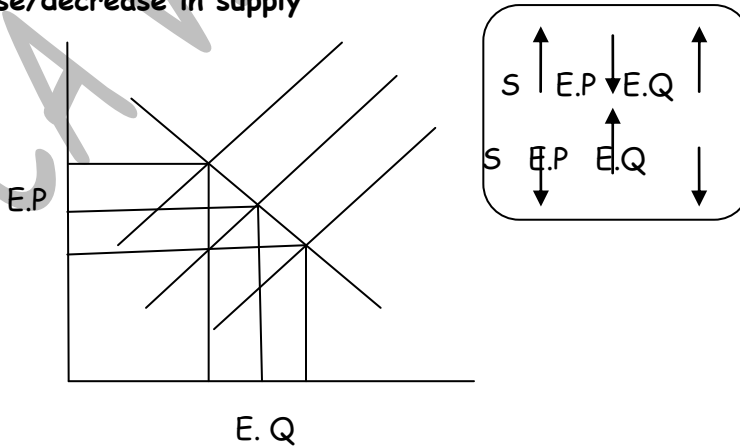

Simultaneous changes in demand and supply

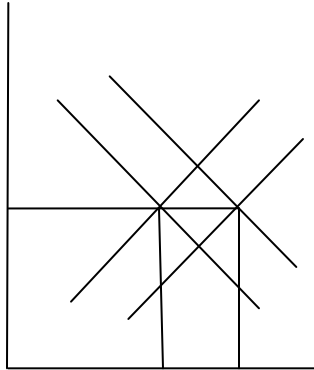

$D \uparrow$  |  $S \uparrow$   
 $E.Q \uparrow$  |  $E.P$  no change

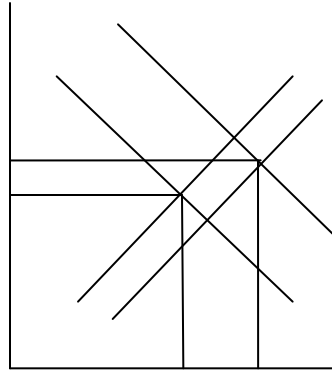

$D \uparrow$  |  $S \downarrow$   
 $E.P \uparrow$  |  $E.Q \uparrow$

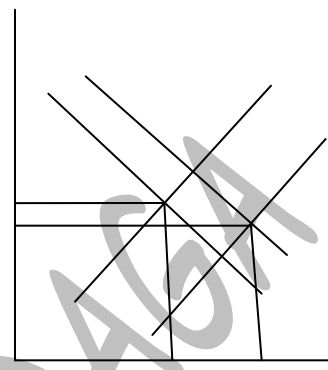

$D \downarrow$  |  $S \uparrow$   
 $E.P \downarrow$  |  $E.Q \uparrow$

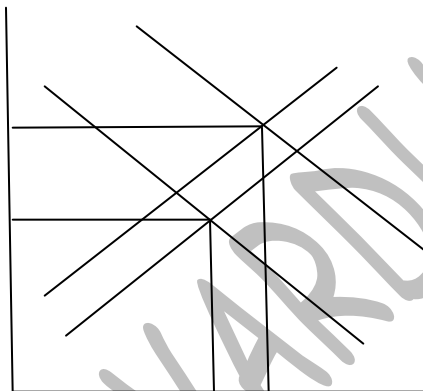

$D \downarrow$  |  $S \downarrow$  |  $E.P \uparrow$  |  $E.Q \downarrow$

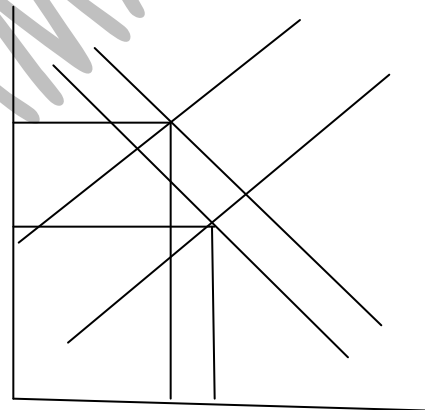

$D \uparrow$  |  $S \downarrow$  |  $E.P \uparrow$  |  $E.Q \downarrow$

UNIT 3 - PRICE OUTPUT DETERMINATION UNDER DIFFERENT MARKET FORMS

Perfect competition

Characteristics

- ✦ Large number of buyers and sellers
- ✦ Homogenous product and perfect substitute
- ✦ Free to entry or exist  
( if all this three conditions are present then there is a pure competition)
- ✦ Perfect knowledge
- ✦ Low transaction cost
- ✦ Firms are price takers

Price determination under perfect competition and short run profit maximization by a competitive firm

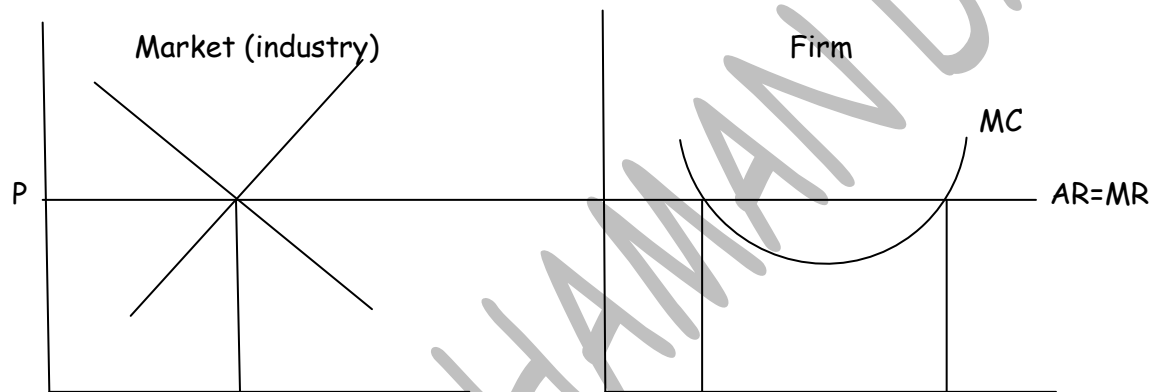

Condition for equilibrium of a firm

- ✦  $MC = MR$
- ✦  $MC$  must be rising

Short run supply curve of the firm in a competitive market

- a)  $P$  below  $AVC$  firm should not continue its production
- b)  $P$  above  $AVC$  firm can produce goods

Can a competitive firm earn profit?

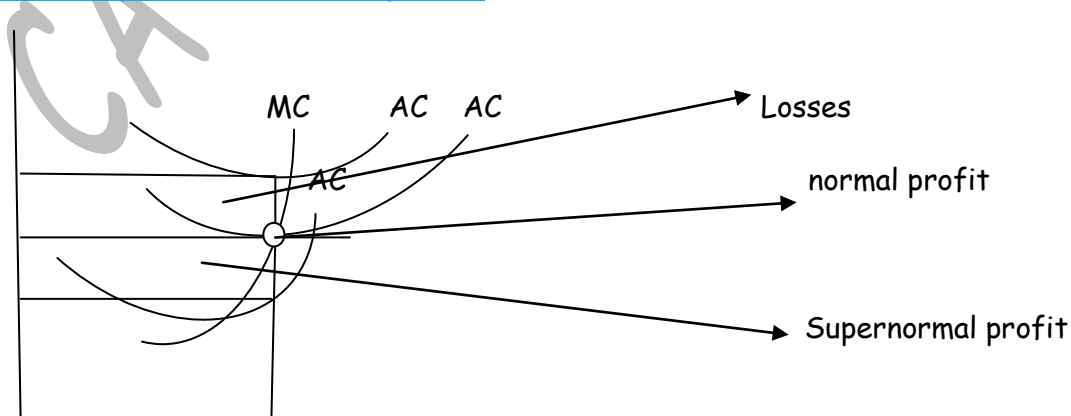

Long run equilibrium of a competitive firm

Firm are in equilibrium in the long run when they have adjusted their plant so as to produce at the minimum point of their long run ATC curve, which is tangent to the demand curve defined by the market price.

Long run equation

$$SMC = LMC = SAC = LAC = P = MR$$

Long run equilibrium of the industry



Monopoly

Features of monopoly market

- Single seller of the product
- Barriers to entry
- No close substitute
- Market power

How to monopoly arise?

- ♣ Strategic control over the resources
- ♣ Unique product
- ♣ Exclusive right to produce and sell a good or a service
- ♣ Patent and copyright
- ♣ Business combination and cartels
- ♣ Large start up
- ♣ Natural monopolies due to very large economies scale
- ♣ Goodwill
- ♣ Stringent legal and regulatory requirements for entry of a new firm
- ♣ Anti-competitive practices

Monopolist's revenue curves

**Monopoly are mainly two types:**

- ♥ **Simple monopoly** - uniform price from all the buyers
- ♥ **Discriminating monopoly** - different prices from different buyers of the same good or service

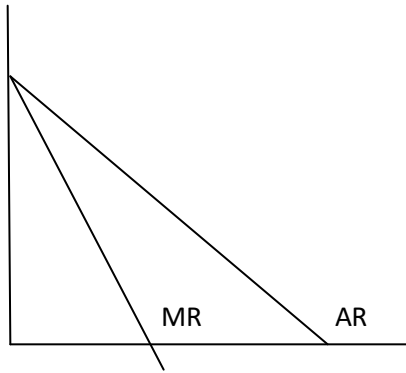

**Short run equilibrium**

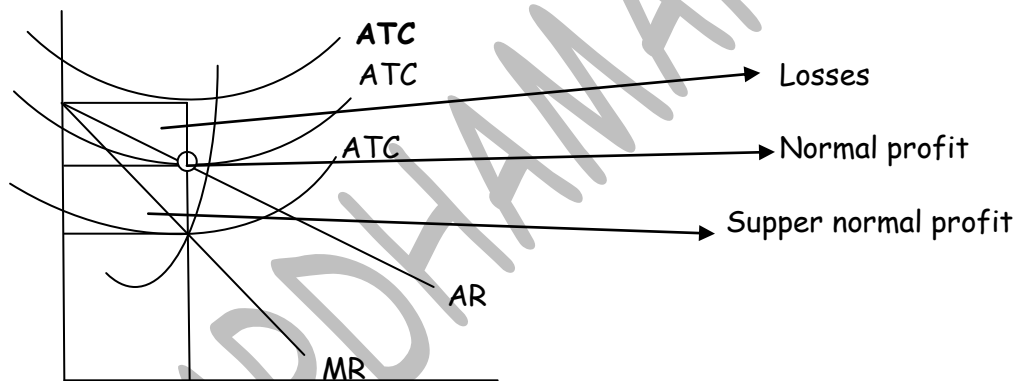

**Price discrimination**

Price discrimination occurs when a producer sells a specific commodity or service to different buyers at two or more different prices for reason not associated with differences in cost.

**Conditions for price discriminations**

- ✚ Control over supply of product
- ✚ Divide market into two or more sub market
- ✚ Price elasticity of the product should be different in different sub-market
- ✚ There must be no market arbitrage
- ✚ Demand is inelastic

$$MR = AR \left[ \frac{e - 1}{e} \right]$$

**Objectives of price discrimination**

## CHAPTER 4 - PRICE DETERMINATION IN DIFFERENT MARKETS

- To earn maximum profit
- To dispose off surplus stock
- To enjoy economies of scale
- To capture foreign market and
- To secure equity through pricing

### Prof. Pigou classified three degree of classification

- ◆ **First degree** - the monopolist separates the market into each individual consumer and charges them the price they are willing and able to pay and thereby extract the entire consumer surplus.
- ◆ **Second degree** - different prices are charged for different quantities of sold. The monopolist will take away only a part of a consumer surplus.
  - a) Different consumers pay different price if they buy different quantities. Larger quantities are available at lower unit price.
  - b) Each consumer pays different price for consecutive purchases.
- ◆ **Third degree** - price varies by attributes such as location or by customer segment.

### Economic effect of monopoly

- Reduces aggregate economic welfare
- Substantially higher prices and produce lower levels of output.
- Earns economic profits which is unjustifiable
- Exceed marginal costs and therefore reduces consumer surplus.
- Restrict consumer sovereignty
- Unjust means for creating barriers
- Political powers used for benefit
- Do not have necessary incentive to introduce efficient innovations
- Pay low prices to the supplier
- Suffer X inefficiency

### Imperfect competition - monopolistic competition

#### Features of monopolistic competition

- ❖ Large number of sellers
- ❖ Product differentiation
- ❖ Freedom of entry and exit
- ❖ Non-price competition
- ❖ Elastic demand

#### Price-output determination under monopolistic competition: Equilibrium of a Firm

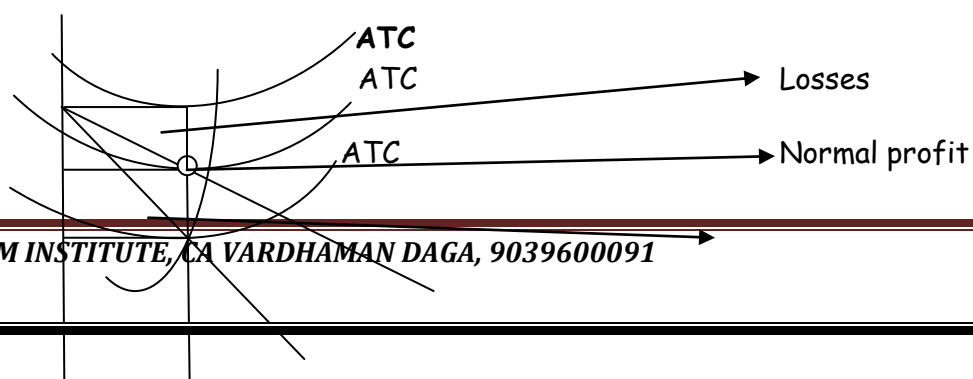

Super normal profit

AR

MR

### Oligopoly

Prof. Stigler defines oligopoly as that "situation in which a firm bases its market policy, in part, on the expected behaviour of a few close rivals

### Types of oligopoly

- ♣ **Pure oligopoly or perfect oligopoly** - when the product is homogeneous in nature
- ♣ **Open and closed economy** - In open new firm can enter and in closed entry is restricted
- ♣ **Collusive and competitive oligopoly** - when there is a common understanding or act in collusion with each other in relation price or output then it is called collusive. If there is absence of understanding then competitive
- ♣ **Partial or full oligopoly** - when industry is dominated by one large firm, the dominating firm will be price leader then it is partial and in absence of price leadership it is called full.
- ♣ **Syndicated and organized oligopoly** - when firms sell their product through a centralized syndicate is called syndicated. When firms organize themselves into a central association for fixing prices, output etc. is called organized

### Characteristics of oligopoly

- ♣ Strategic interdependence
- ♣ Importance of advertising and selling costs
- ♣ Group behaviour

### Price and output decision in an Oligopolistic Market

- ✚ Some oligopolistic firms ignore interdependence so their demand curve is definite.
- ✚ Some oligopolistic firms predict the pattern of competitors and make decisions relating to price and quantity
  - a. **Cournot model** - the firm's control variable is output in contrast to price. They do not collude
  - b. **Stackelberg's model** - the leader commits to an output before all other firms. The rest of the firms are followers and they choose their output so as to maximize profits, given the leader's output.
  - c. **Bertrand model** - price is the control variable for firms and each firm independently sets its price in order to maximize profits
- ✚ Third approach oligopolistic firms enter into agreement and try to pursue their common interests.



### Price leadership

A group of firms that explicitly agree (collude) to co-ordinate their activities is called a cartel. Here the firms set the price in such a way that big firms and small firms both are benefited.

### Kinked demand curve

Kinked demand curve hypothesis given by an American economist Paul A. Sweezy. This is called as Sweezy Model.

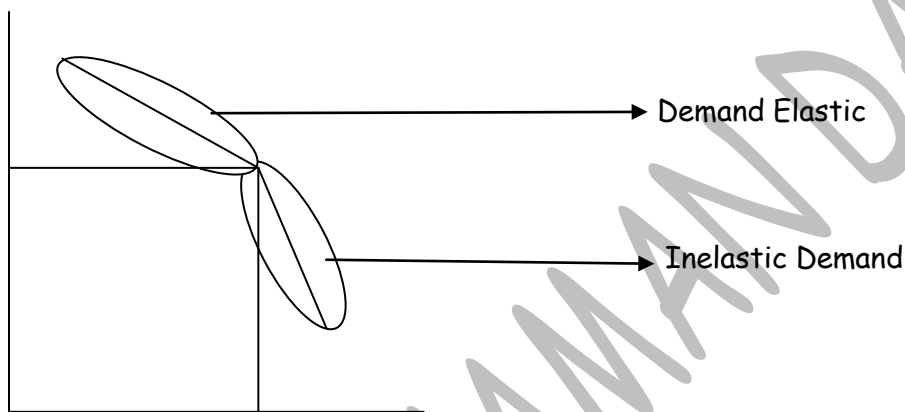

Demand is elastic as firm lower price so that the demand of the product increases. So in starting firms takes the advantage of increase in demand but when other firms also reduce the price then the benefit of reduced is not received

### Other important market forms

- ♥ Duopoly - two firms
- ♥ Monopsony - single buyer of product
- ♥ Oligopsony - small number of large firms
- ♥ Bilateral monopoly - single seller and a single buyer.

**BUSINESS CYCLE**

Business cycle refers to alternative expansion and contraction of overall business activity as manifested in fluctuations in measures of aggregate economic activity, such as, gross national product, employment and income.

**Phases of business cycle**

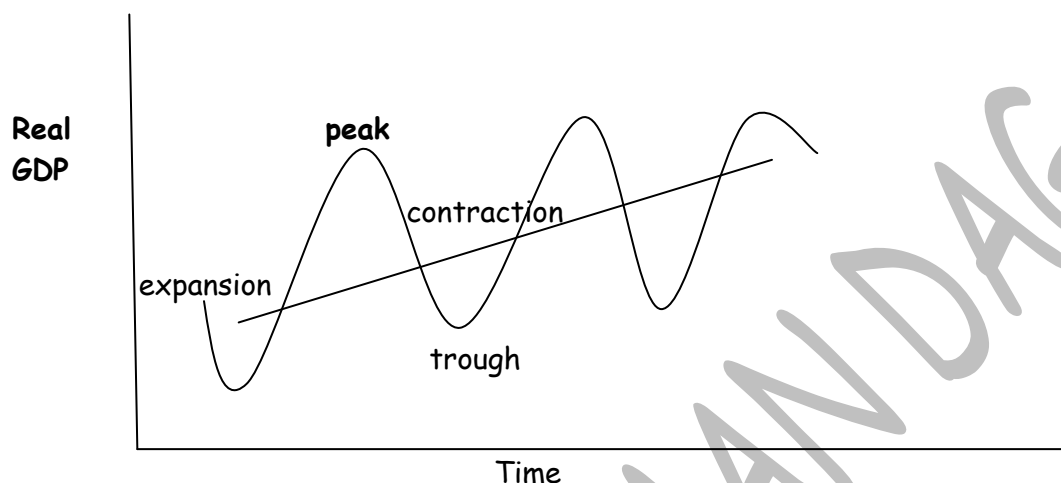

**Expansion**

- Increase in national output, employment, aggregate demand
- Full employment
- Involuntary employment is zero and unemployment is either frictional or structural
- Prices and cost tends to rise
- High prosperity and high standard of living
- Growth rate eventually slows down and reaches its peak

**Peak**

- + Highest point of business cycle
- + Shortage of demand and inputs are difficult to find, input price increases
- + Output price rises, rising cost of living
- + Consumer begin to review expenditure
- + Actual demand stagnates
- + Economic growth stabilize and moves in reverse direction

**Contraction**

- Fall in level of investment and employment
- Producers anticipate higher level of demand
- Discrepancy or mismatch in demand and supply
- Supply exceed demand
- Stoppage of production and beginning of recession
- Business firm becomes pessimistic

### Trough and depression

- ❖ *Severe form of recession*
- ❖ *Extremely sluggish economic activities*
- ❖ *Growth rate becomes negative, level of national income and expenditure declines rapidly.*
- ❖ *Typical feature of depression is the fall in interest rate*
- ❖ *At the depth of depression, all economic activities touch the bottom and the phase of trough is reached.*

### Recovery

- ♣ *End of pessimism and beginning of optimism*
- ♣ *First seen in labour market*
- ♣ *Producer expects lower cost and better business environment*
- ♣ *All things goes favourable and depression turns into expansion*

### Indicators

Economists use changes in a variety of activities to measure the business cycle and to predict where the economy is headed towards.

**Leading indicators** - is a measurable economic factor that changes before the economy starts to follow a particular pattern or trend

**Lagging indicators** - reflects the economy's historical performance and changes in these indicators are observable only after an economic trends or pattern has already occurred

**Coincident indicator** - also called as concurrent indicators, coincide or occur simultaneously with the business-cycle movements.

Example of business cycle

- ✓ Great depression of 1930
- ✓ Information technology bubble burst of 2000
- ✓ Global economic crises (2008-09)

### Features of business cycle (BC)

- Occurs periodically and do not exhibit same regularity
- BC have 4 phases
- BC originate in free market economies
- BC affects capital goods industries, durable consumer goods industry etc disproportionately and agriculture and industrial sector are adversely affected
- BC are exceedingly complex phenomena
- Repercussions of business cycles get simultaneously felt on nearly all economic variables
- BC are contagious and are international in character
- BC have serious effect on society

**Causes of business cycle**

**Internal causes**

- ◆ *Fluctuations in effective demand*
- ◆ *Fluctuations in investment*
- ◆ *Variations in government spending*
- ◆ *Macroeconomic policies*
- ◆ *Money supply*
- ◆ *Psychological factors*

**External causes**

- ♥ *War*
- ♥ *Post war reconstruction*
- ♥ *Technology shock*
- ♥ *Natural factors*
- ♥ *Population growth*

## CHAPTER - 1 BCK - AN INTRODUCTION

### Domains of business and commercial knowledge (BCK)

**Domains** is defined as a specified sphere of knowledge (in simpler term subject)

- ✦ BCK is **vast**
- ✦ BCK is **eclectic (multidisciplinary)**
- ✦ BCK is **ever evolving and expanding**

### Importance of BCK for Chartered Accountant

- ❖ **Large share** of their work arena.
- ❖ Each business has its **own peculiarities and associated variations** in notions of product, inventory, revenue, profit etc.
- ❖ **CA's can add value** to their work if they understand the nuances of the business.
- ❖ **CA's can audit diligently, take decisions, strategies, make plans and budgets.**

### Human activities - economic and non-economic

<b>Economic activities</b>	<b>Non-economic activities</b>
All that we do to earn a living comprises	Concern for fellow beings, affection & love for family etc.
Rationality or Self-interest	Emotional or sentimental reasons or altruism
Non-economic activities have an economic dimensions as time money and material are required	
The motive or intent behind any activity defines it as economic or non-economic activities	

### Characteristics of Economic activities -

- ♥ Economic activities are **income generating**
- ♥ Economic activities are **productive**
- ♥ Even consumption is an **economic activity**
- ♥ **Saving, investment and wealth**

### Business as an economic activity

- **Market oriented production** represents supply side of economics
- Shift from subsistence driven production towards **commercialisation of production.**
- **Broader prospective**, business may be defined as an economic activity comprising the entire spectrum of activities pertaining to production, distribution and trading (exchange) of goods and services.
- In India, **agriculture does not comprise industry and hence business.**
- **Medium prospective**, business refers to a particular type of activity or industry
- **Narrow prospective**, business may be defined as one's usual occupation of creating, owing and actively operating an economic organisation i.e. a firm.

## CHAPTER - 1 BCK - AN INTRODUCTION

- **Layer 1** - commerce (includes all types of economic activity)
- **Layer 2** - specific type of industry
- **Layer 3** - daily occupation

### Distinguishing characteristics of business vis-à-vis other economic occupations

S. No	Basis of Distinction	Business	Profession	Employment
1.	<b>Meaning</b>	Entire spectrum of market-oriented activities coming under industry, trade and commerce	Independent rendering of services of specialised nature based on prescribed qualifications under the aegis of a professional body that also prescribes a code of conduct	Rendering of services under a contract of employment for wages/ salaries. Also, called wages-employment.
2.	<b>Mode of establishment</b>	Entrepreneur's decision and other legal formalities, if necessary	Membership of a professional body and certificate of practice	Letter of appointment and service agreement
3.	<b>Source of livelihood</b>	Profit	Professional fee	Wages and salaries
4.	<b>Prescribed qualification</b>	None	Strictly prescribed	Minimum qualification for each type of job
5.	<b>Ethical guidance</b>	Founder's value	Professional codes	Employer's codes
6.	<b>Investment</b>	Substantial requirement	Some requirement	None
7.	<b>Personal autonomy/freedom</b>	The most you are own boss	Quiet a bit	Not much
8.	<b>Popular psychological motive</b>	Economic achievement	Service to the client/society	Livelihood
9.	<b>Certainty of income</b>	Least	Quiet a bit	The most
10.	<b>Stability of tenure/durability of occupation</b>	Uncertain	Quite certain	Quiet certain
11.	<b>Transfer of</b>	Possible	Not possible	Not possible

## CHAPTER - 1 BCK - AN INTRODUCTION

.	<b>interest/succession</b>		
---	----------------------------	--	--

### Characteristics of business -

- *Job creator, not job seeker*
- *Provides momentum to economic growth and development*
- *Investment intensive*
- *Gestation and uncertainties*
- *Systematic, organised, efficiency-oriented activity.*
- *Objective oriented/purposeful*

Economic objectives	Organic objectives	Social objectives	Legal, ethical and environmental objectives
Sales, profits, return on investment, efficiency, economic value added	Survival, health, growth, diversification of capabilities	Community service, education, health, sanitation, heritage conservation, support during calamities & disasters etc. Specific responsibilities towards employees, investors, customers, suppliers, competitors etc.	Respect for law in letter and spirit, fair practices, transparency, truthfulness, honesty & integrity. Green technologies, product-usage & disposal, lower emissions, effective waste handling and disposal, preservation of air, water and soil quality.

### Forms of business organisation

- ✦ Business ownership is a **bundle of rights**
- ✦ Business may be **owned singly or jointly**
- ✦ Business may be organised as a **proprietary or a corporate concern**

### Sole proprietorship

<i>Easiest and the earliest form of business</i>	<i>Economic hero</i>	<i>One-person band</i>
<i>Small scale</i>	<i>Enjoy people trust and provide personalised services</i>	<i>Unorganized or informal sector</i>
<i>These enterprises are largest</i>	<i>Contribution to GDP, Employment and even exports</i>	<i>Indirect contribution to large suppliers</i>
<i>Products are often derogatorily called 'local'.</i>	<i>Poor working condition</i>	<i>Hire and fire policy</i>
<i>Lack of employee welfare</i>	<i>Lack of social and environmental concerns</i>	<i>Fate of the enterprise is linked with the personal well-being of the owner.</i>
<i>Relies on personal savings and</i>	<i>Obtain micro-finance and</i>	<i>Can act as business</i>

## CHAPTER - 1 BCK - AN INTRODUCTION

<i>assets</i>	<i>bank finance</i>	<i>facilitators</i>
<i>Keep all profits and bear all risks</i>		

Features	Whether merits or limitations
Autonomy of being one's own boss	Merit
Sole provider of capital	Limitations
Visibility of the owner and personalised services	Merit
Sole bearer of risks	Limitation
Unlimited liability	Limitation
Fate of going concern	Limitation
Succession of ownership	By will or application of the law of inheritance.

### Hindu Undivided Family (HUF) Business

Enjoys separate entity status under Income tax act	HUF cannot earn income from salary	Three successive generations of an undivided family are known as HUF
Hindu Succession Act, 1956		

Features	Whether merit or limitation
Formed by birth in a Hindu	Merit
Family pool of resources	Merit
Social capital through family involvement	Merit
The family members are automatic co-owners (called co-parceners) by birth	Limitation
Decision making is quick	Merit
Unlimited liability of the karta	Limitation
Fate of going concern	Limitation
Succession of ownership	By will or application of the law of inheritance.

### Partnership

Contractual co-ownership of a business	Agree to share profit	Indian partnership Act, 1932
--	-----------------------	------------------------------

Features	Whether merit or limitation
Agreement	Merit
Two or more persons	Merit and limitation
Profit sharing	Merit
Business objects quite wide	Merit



## CHAPTER - 1 BCK - AN INTRODUCTION

Mutual agency	Merit and limitation
Unlimited liability	Limitation
Fate as a going concern	Limitation
Succession of ownership	Limitation

### Limited Liability Partnership (LLP)

Liability of partner is limited	Mandatory incorporated/registered	Designated partner
Separate legal entity	Perpetual succession	Hybrid form of business

Features	Whether merit or limitation
Limited liability	Merit
Incorporation is mandatory	Merit
Legal entity separate from its members	Merit
Minimum 2 and no limit on maximum number of members	Merit
ROC is the administrating authority	Merit
Statutory compliances	Limitation
Every partner of LLP is only agent of firm	merit

### Company

Elaborate system of corporate functioning	Regulation of capital market
MOA, AOA, prospectus	Statutory audit, quarterly audit, listing
Indian corporate sector is numerically dominated by private limited companies	

	Features of private company	Features of public company
Minimum number of members	2	7
Maximum number of members	200	No limit
Transfer of shares	Restricted	Freely transferable
Directors	2	3
Committees	Exempted	Audit committee, CSR committee, stakeholder committee and the Nomination and Remuneration committee
Start business	Upon incorporation	After certificate of commencement of business

## CHAPTER 2 - BUSINESS ENVIRONMENT

### Meaning of Business Environment

**According to Gluek and Jauch** - "The environment includes factors outside the firm which can lead to opportunities for, or threats to the firm. Although, there are many factors, the most important of the factors are socio-economic, technological, supplier, competitors, and government."

### Characteristics of business environment

Complex	Dynamic	Multi-faceted
Far reaching impact		

### Importance of business environment

Determining opportunities and threats	Giving direction for growth	Continuous learning
Image building	Meeting competition	

### Relationship between organisation and its environment

- ✦ Exchange of information
- ✦ Exchange of resources ( 5 M's Men, Money, Method, Machine, Material)
- ✦ Exchange of influence and power

### Environmental influences on business

Environmental factors or constraint are largely if not totally, external and beyond the control of individual industrial enterprises and their managements. These are essentially the 'givers' within which firms and their managements must operate in a specific country and then vary, often greatly, from country to country.

**Business functions as a part of broader environment** - inputs in different form is converted into product/services and latter income generated is used for economic growth and development

### Framework to understand the environmental influences

- **Firstly**, initial view of the nature of the organization environment in terms of how uncertain it is.
- **Secondly**, auditing of environmental influences
- **The final step**, explicit consideration of the immediate environment of the organization

### Why environmental analysis?

To identify the demand of environment and changing its strategy

### Utility of environmental analysis

From environmental analysis, strategists get time to anticipate opportunities and to plan optimal responses to these opportunities. It also helps strategists to develop an early warning system to prevent threats or to develop strategies which can turn a threat to the firm's advantage.

## CHAPTER 2 - BUSINESS ENVIRONMENT

### Purpose of environmental analysis

- ◆ **First**, understanding of current and potential changes
- ◆ **Second**, inputs for strategic decision making
- ◆ **Third**, facilitate and foster strategic thinking in organisation

### Environmental scanning

Environmental scanning can be defined as the process by which organizations monitor their relevant environment to identify opportunities and threats affecting their business for the purpose of taking strategic decisions.

- ♣ **Events** are important and specific occurrences
- ♣ **Trends** are the general tendencies or the courses of action along which events takes place.
- ♣ **Issues** are the current concerns that arise in response to events and trends.
- ♣ **Expectations** are the demands made by interested group in the light of their concern for issues.

### Components of business environment

**Internal environment** - is composed of multiple elements existing within the organisation, including management, current employees and corporate cultures.

**External environment** - these factors that happen outside the business are known as external factors or influences. There are two major types of external environment:

- ❖ Micro environment
- ❖ Macro environment

The four environmental influences could be described as follows:

- A **Strength is an inherent capacity** which an organization can use to strategic advantage over its competitors
- A **weakness is an inherent limitation or constraint** which creates a strategic disadvantage.
- An **opportunity is a favourable condition** in the organization's environment which enables it to consolidate and strengthen its position
- A **threat is an unfavourable condition** in the organization's environment which creates a risk for, or caused damage to, the organization.

### SWOT Analysis

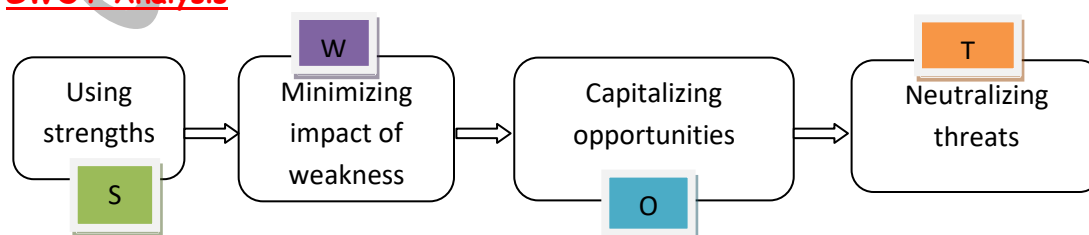

## CHAPTER 2 - BUSINESS ENVIRONMENT

### Micro and Macro Environment

**Micro environment** is related to small area or immediate periphery of an organization.

Following issues to be address:

- *Employee of the firm*
- *Customer base*
- *Finance*
- *Firm suppliers*
- *Local community*
- *Direct competition*

**Micro environment** are specific and short term but regular basis. Micro environment consists of:

Customers	Organization	Market
Intermediaries	Competitors	Suppliers

Macro environment has broader dimensions and for long period. The issues are:

- *Threat from competitive world*
- *Technology*
- *Bargaining/dominance of supplier and customers*

Macro environment consists of:

Demographic	Political	Economic
Social	Technological	Government
Legal	Global	

### Elements of micro environment

- ✦ **Customers/consumers** - according to Peter Druker the main aim of business is to create and retain customers.
- ✦ **Competitors** - may be direct or indirect. Direct means which are in same business activity, selling the same product, products which are related to each other or are exactly the same. Indirect means were product/services are different.
- ✦ **Organization** - owners, Board of Directors, employees.
- ✦ **Market** - key issues are:
  - ◆ Cost structure of the market
  - ◆ The price sensitivity of the market
  - ◆ Technologies structure of the market
  - ◆ The existing distribution system of the market
  - ◆ Is the market mature
- ✦ **Suppliers** - important component. Organization need to take major decision regarding 'outsourcing' or 'in-house' production depending upon supplier environment.
- ✦ **Intermediaries**

## CHAPTER 2 - BUSINESS ENVIRONMENT

---

### Elements for Macro Environment

- ♥ **Demographic environment** -
  - Population size (population growth rate and life expectancy rate)
  - Geographic distribution (from region to region)
  - Ethnic mix (relating to or characteristics of a human group)
  - Income distribution (level of individual and group purchasing power)
- ♥ **Economic environment** - refers to the nature and direction of the economy in which a company competes or may compete.  
Factors that affect the economic environment:
  1. Economic systems
    - ♣ Capitalism
    - ♣ Socialism
    - ♣ Mixed economy
  2. Economic conditions or factors
  3. Economic policies
    - Industrial policy
    - Fiscal policy
    - Monetary policy
    - Foreign investment policy
    - Export-import policy (Exim policy)
- ♥ **Political-legal environment** -
  - Government
  - Legal
  - Political
- ♥ **Socio-culture environment** - some of the important factors and influences operating in the socio-cultural environment are:
  - ♣ Social concerns,
  - ♣ Social attitudes and values
  - ♣ Family structure and changes in it
  - ♣ Role of women in society
  - ♣ Education levels
- ♥ **Technological environment** - following factors to be considered:
  - ❖ Pull of technological change
  - ❖ Opportunities arising out of technological innovation.
  - ❖ Risk and uncertainty of technological development.
  - ❖ Role of R&D in a country and government's R&D budget
- ♥ **Global environment** - following factors to be considered:
  - ✓ Potential positive and negative impact of significant international events.
  - ✓ Identification of both important emerging global markets and changes.

## CHAPTER 2 - BUSINESS ENVIRONMENT

---

- ✓ Differences between cultural and institutional attributes of individual global markets.

### PESTLE ANALYSIS

- × **Political factors** are how and to what extent the government intervenes in the economy and the activities of business firms.
- × **Economic factors** have major impacts on how businesses operate and take decisions.
- × **Social factors** affects the demand for a company's products and how that company operates.
- × **Technological factors** can determine barriers to entry, minimum efficient production level and influence outsourcing decisions.
- × **Legal factors** affect how a company operates, its costs, and the demand for its products, ease of business.
- × **Environmental factors** affect industries such as tourism, farming, and insurance.

Political	Economic	Social
<ul style="list-style-type: none"> <li>• Political stability</li> <li>• Political principles and ideologies</li> <li>• Current and future taxation policy</li> <li>• Regulatory bodies and processes</li> <li>• Government policies</li> <li>• Government term and change</li> <li>• Thrust areas of political leaders</li> </ul>	<ul style="list-style-type: none"> <li>• Economic situation and trends</li> <li>• Market and trade cycles</li> <li>• Specific industry factors</li> <li>• Customer/end-user drivers</li> <li>• Interest and exchange rates</li> <li>• Inflation and unemployment</li> <li>• Strength of consumer spending</li> </ul>	<ul style="list-style-type: none"> <li>• Lifestyle trends</li> <li>• Demographics</li> <li>• Consumer attitudes and opinions</li> <li>• Brand, company, technology image</li> <li>• Consumer buying patterns</li> <li>• Ethnic/religious factors</li> <li>• Media views and perception</li> </ul>
Technological	Legal	Environment

## CHAPTER 2 - BUSINESS ENVIRONMENT

<ul style="list-style-type: none"><li>• Replacement technology/solution</li><li>• Maturity of technology</li><li>• Manufacturing maturity and capacity</li><li>• Innovation potential</li><li>• Technology access, licensing, patents</li><li>• Intellectual property rights and copyrights</li></ul>	<ul style="list-style-type: none"><li>• Business and corporate law</li><li>• Employment law</li><li>• Competition law</li><li>• Health &amp; safety law</li><li>• International treaty and law</li><li>• Regional legislation</li></ul>	<ul style="list-style-type: none"><li>• Ecological/environmental issues</li><li>• Environmental hazards</li><li>• Environmental legislation</li><li>• Energy consumption</li><li>• Waste disposal</li></ul>
---	---	---

### Strategic responses to the environment

#### a) Internal strategic responses

- ✦ **Administrative responses** - formation or clarification of the organization's mission; the development of objectives, policies, and budgets; or the creation of scanning units.
- ✦ **Competitive response** - competitive responses to the environment typically are associated with for-profit firms.
- ✦ **Collective response** - when two or more businesses come together to benefit from each others advantages, its termed as collective responses.

#### b) Holistic strategic responses

- ✦ **Least resistance** - eg. BSNL
- ✦ **Proceed with caution** - eg. Airtel
- ✦ **Dynamic response** - eg. Reliance Jio

## CHAPTER 3 - BUSINESS ORGANISATION

S.No	Company name	Incorporation year	Headquarters	Chairman	Present managing director	Chief executive officer	Chief financial officer	Ranking in Forbes World's Largest Public Corporations List 2021	Ranking in Forbes World's Best Employer's List 2021
1	Adani Ports and special Economic Zone Ltd.	1998	Ahmedabad, Gujarat, India		Gautambhai Shantilal Adani	Karan Gautambhai Adani	Deepak Maheshwari	1489 <sup>th</sup>	
2	Asian Paints Ltd.	1942	Mumbai, Maharashtra, India		Amit Syngle	Amit Syngle	RJ Jeyamurugan	1536 <sup>th</sup>	
3	Axis Bank Ltd.	1993	Mumbai, Maharashtra, India		Amitabh chaudhry	Amitabh chaudhry	Puneet Sharma	585 <sup>th</sup>	254 <sup>nd</sup>
4	Bajaj Auto Ltd.	1945	Pune, Maharashtra, India	Rahul Bajaj	Rajiv bajaj	Rajiv bajaj	Dinesh Thapar	1620 <sup>TH</sup>	
5	Bharti Airtel Ltd.	1995	New Delhi, India	Sunil Bharti Mittal	Gopal Mittal	Gopal Mittal	Soumen Ray	725 <sup>th</sup>	
6	Bharat Petroleum Corporation Ltd.	1952	Mumbai, Maharashtra, India	Arun Kumar Singh	Arun Kumar Singh	K Padamkar	Ramakrishna Gupta Vetsa	792 <sup>st</sup>	
7	Cipla Ltd.	1935	Mumbai, Maharashtra, India	Y K Hamied	Umang Vohra	Umang Vohra	Kedar Upadhye		460 <sup>th</sup>
8	Coal India Ltd	1975	Kolkata, West		Pramod	Pramod Agrawal	Sunil Kumar	770 <sup>th</sup>	



## CHAPTER 3 - BUSINESS ORGANISATION

			Bengal, India		Agrawal		Mehta		
9	Dr. Reddy's Lab Ltd.	1984	Hyderabad, Telangana, India	Kallam Satish Reddy		Erez Israeli	Parag Agrawal		
10	Flipkart	2007	Singapore (legal domicile) Bengaluru, Karnataka, India (operational headquarters)			Kalian krishnamurthy	Sriram Venkataraman		
11	GAIL (India) Ltd.	1984	New Delhi, India	Manoj Jain	Manoj Jain	Manoj Jain	A K Tiwari	1377 <sup>th</sup>	
12	HDFC Bank Ltd	1994	Mumbai, Maharashtra, India	Deepak S Parek	Sashidhar jagdishan		Srinivasan vaidyanathan	116 <sup>th</sup>	77 <sup>th</sup>
13	ICICI Bank Ltd.	1994	Mumbai, Maharashtra, India	Girish Chandra Chaturvedi	Sandeep Bakhshi	Sandeep Bakhshi	Rakesh Jha	182 <sup>nd</sup>	65 <sup>th</sup>
14	Indian Oil Corporation Ltd	1959	New Delhi, India	Shrikant Madhav Vaidya			Sandeep Kumar Gupta	599 <sup>th</sup>	
15	Infosys Ltd	1981	Bengaluru, Karnataka, India	Nandan Nilekani	Salil Parekh	Salil Parekh	Nilanjan Roy	492 <sup>nd</sup>	588 <sup>th</sup>
16	ITC Ltd	1910	Kolkata, West Bengal, India	Sanjiv Puri	Sanjiv Puri	Sanjiv Puri	Supratim Dutta	833 <sup>rd</sup>	453 <sup>rd</sup>
17	Larsen & Toubro Ltd	1938	Mumbai, Maharashtra, India	Anil Manibhai Naik	S.N Subrahmanya n	S.N Subrahmany n	Shankar Raman	366 <sup>th</sup>	127 <sup>th</sup>
18	NTPC Ltd.	1975	New Delhi, India	Gurdeep singh		Gurdeep singh	Anil Kumar Gautam	513 <sup>th</sup>	
19	Oil & Natural Gas Corporation Ltd.	1956	Uttarakhand India	Dr. Alka Mittal	Dr. Alka Mittal		Anurag Sharma	665 <sup>th</sup>	404 <sup>th</sup>
20	Power Grid	1989	Gurugram,	Sreekant	Sreekant		Mohammed	796 <sup>th</sup>	

## CHAPTER 3 - BUSINESS ORGANISATION

	Corporation of India Ltd.		Haryana, India	Kandikuppa	Kandikuppa		Taj Mukarrum		
21	Reliance Industries Ltd.	1966	Mumbai, Maharashtra, India	Mukesh Ambani	Mukesh Ambani	Mukesh Ambani	Srikanth Venkatchari and Alok Agrawal	55 <sup>th</sup>	52 <sup>nd</sup>
22	State Bank of India	1806	Mumbai, Maharashtra, India	Dinesh Kumar Khara	C.S Setty Ashwani Bhatia, Swaminathan J., Ashwini Kumar Tewari		Charanjit Surinder Singh Attra	110 <sup>th</sup>	119 <sup>th</sup>
23	Tata Sons Private Ltd	1868	Bombay House, Mumbai, Maharashtra, India	Natarajan Chandrasekaran	Natarajan Chandrasekaran		Sourabh Agrawal and Eruch Noshir Kapadia	Tata Motors-784 <sup>th</sup> TCS-322 <sup>nd</sup> Tata Steel-939 <sup>th</sup>	Tata group – 746 <sup>th</sup>
24	Wipro Ltd	1945	Bengaluru, Karnataka, India	Rishad Premji	Rishad Premji	Thierry Delaporte	Jatin Dalal	769 <sup>th</sup>	

### GLOBAL COMPANIES

S.No	Company name	Incorporation year	Headquarters	Chairman	Chief executive officer	Chief financial officer	Ranking in Forbes World's Largest Public Corporations List 2021	Ranking in Forbes World's Best Employer's List 2021`	Ranking in Fortune 500 Companies List 2021

## CHAPTER 3 - BUSINESS ORGANISATION

1	Amazon	1994	Seattle, Washington, U.S	Jeff Bezos	Jeff Bezos	Brain T. Olsavasky	10 <sup>th</sup>	4 <sup>th</sup>	2 <sup>nd</sup>
2	American Express	1850	New York, Unites States of America	Stephen Squeri	Stephen Squeri	Jeffery C Campbell	95 <sup>th</sup>	245 <sup>th</sup>	312 <sup>th</sup>
3	Apple	1977	California, United States of America		Time Cook	Luca Maestri	6 <sup>th</sup>	5 <sup>th</sup>	3 <sup>th</sup>
4	Goldman sachs	1869	New York, United States of America	David M. Solomon	David M. Solomon	Stephen Scherr	26 <sup>th</sup>	660 <sup>th</sup>	59 <sup>th</sup>
5	HP Inc.	1939	California, United States of America	Charles Victor Bergh	Enrique Lores	Marie Myers	709 <sup>th</sup>	197 <sup>th</sup>	56 <sup>th</sup>
6	IBM Corporation	1911	New York, United States of America	Arvind Krishna	Arvind Krishna	James J. Kovnaugh	59 <sup>th</sup>	2 <sup>nd</sup>	42 <sup>nd</sup>
7	Intel Corporation	1968	California, United States of America	Omar Ishrak	Patrick Paul Gelsinger	George Davis	36 <sup>th</sup>	69 <sup>th</sup>	40 <sup>th</sup>
8	Microsoft Corporation	1975	Washington,	John W. Thompson	Satya Nadella	Amy Hood	15 <sup>th</sup>	3 <sup>rd</sup>	15 <sup>th</sup>
9	Nestle	1866	Vevey, Switzerland	Paul Bulcke	Ulf Mark Schneider	Francois-Xavier Roger	39 <sup>th</sup>	501 <sup>th</sup>	
10	Walmart	1969	Arkansas, United	Gregory B, Penner	Dough McMillon	Bret Biggs	18 <sup>th</sup>		1 <sup>st</sup>

## CHAPTER 3 - BUSINESS ORGANISATION

---

			States of America					
--	--	--	----------------------	--	--	--	--	--

CA VARDHAMAN DAGA

## CHAPTER 4 - GOVERNMENT POLICIES FOR BUSINESS GROWTH

### Policy Framework in India - A historical sketch

#### Ancient India

- ◆ Universities of takshashila, vaishali and nalanda
- ◆ Chanayaka outlined public policy and book 'Arthashastra'.
- ◆ Ashoka introduced the policy of peace and harmony
- ◆ Guptas defined policies on taxes, trade and warfare.
- ◆ Alauddin khilji introduced stringent tax reforms
- ◆ During the time of Akbar, land reforms were introduced

#### India under the british rule

- ♥ Dadabhai Naoroji through his seminal work 'His book Poverty and Un-British Rule in India'.
- ♥ Zamindari system

#### India since Independence

- ♣ First industrial policy 1948
- ♣ Preamble of constitution adopted in 1950
- ♣ First five year plan in 1951
- ♣ Industrial policy resolution 1956
- ♣ LPG policy 1991

Policy regime of mid fifties	Policy regime since 1990s
Mixed economy, with dominant public sector	Capitalistic economy
Economic planning	Market mechanism
Closed economy policies	Open economy policies - towards globalization
Acquiring commanding heights through public sector undertakings	State ownership of business as exception; privatisation of public sector undertakings
Regulation and control	Liberalisation of regulation

#### Spectre of government policies for business

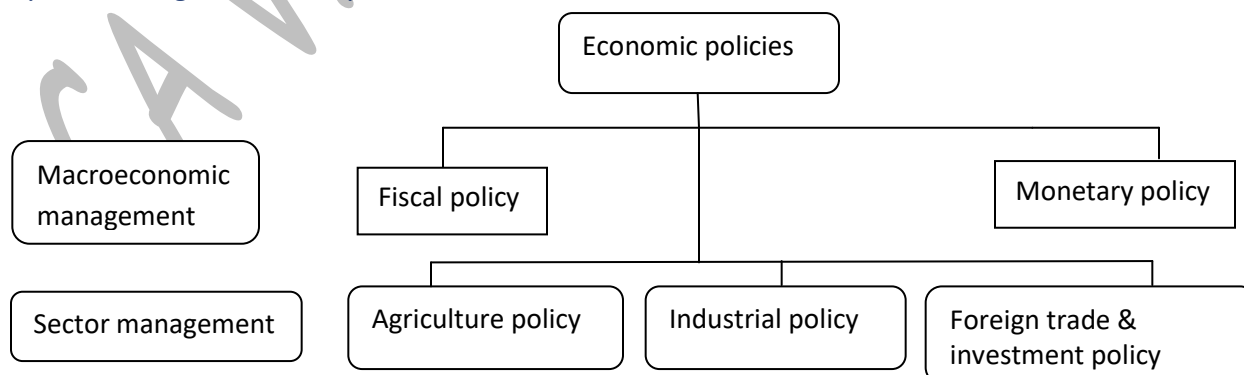

## CHAPTER 4 - GOVERNMENT POLICIES FOR BUSINESS GROWTH

**Fiscal policies** - that is the policies relating to the government expenditure and tax and non-tax revenue.

**Monetary policies** - that is policies relating to supply of money, credit and foreign exchange broadly impact the business.

**Sectoral policies** - pertain to the specific sectors of the economy.

### Macro policy indicators and business conduciveness

**GDP, inflation, tax rates, interest rates, and exchange rates** are the five most significant macro policy indicators impact business.

Variable	Direction	Meaning
GDP	Rising	Economic optimism; high demand expectation
Inflation	Moderate	Demand and profit expectation
Tax	Lower	Incentive for investors in the form of post-tax business income
Interest	Lower	Lower cost of funds
Exchange	Moderate	Protection to domestic production; incentive for exports

### Policy formulation and impact transmission process

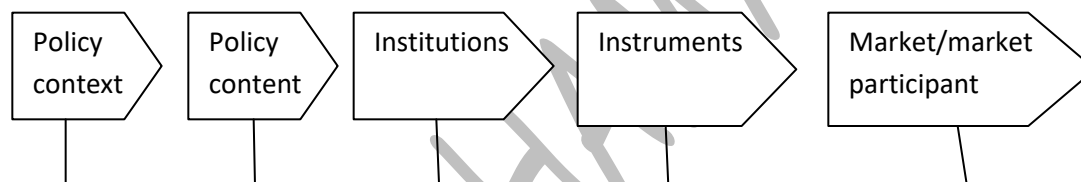

The process is bi-directional.

### Types of government policies by intended impact

- ✦ **Protective policies** - aim to provide protection to the businessman so that these may sustain themselves and grow. Eg. Inward looking trade strategy
- ✦ **Restrictive policies** - put a curb on business growth lest it should become detrimental to the interest of the consumers and public at large. Eg. MRTP act
- ✦ **Regulatory policies** - policies aim at putting in place an institutional set up for the organised functioning of the relevant activity/market. Eg. RBI
- ✦ **Facilitative/developmental policies** - are the ones which facilitates an activity. Eg. MSMEs and NSDC.

### The economic change process

#### Liberalization

- ❖ Remove or loosen restrictions
- ❖ Dismantling of licensing and permits, regulation, easing of approvals,
- ❖ Systematic loosening of legislative and administrative controls over business.

## CHAPTER 4 - GOVERNMENT POLICIES FOR BUSINESS GROWTH

---

- ❖ Liberalization may be defined as a systematic process of the enlargement and enhancement of the freedom of the private sector in the economy.
- ❖ 18 industries reduced to 3 industries i.e. defense aircraft and warships, atomic energy generation, and railway transport.
- ❖ Industrial licensing abolished except for alcohol, cigarettes, industrial explosives, aerospace, drugs and pharmaceuticals.

### Privatization

- ❖ Refers to a managerial approach of changing the ownership structure of one or more government owned institutions.
- ❖ Higher flexibility and scope of innovation
- ❖ Enhance market potencies by enhancing efficiency, quality and competitiveness.
- ❖ Effective tool for rapid restructuring and reforming the public sector.
- ❖ **Delegation** - government keeps hold of responsibility and private enterprise handles fully or partly the delivery of product and services. There is active involvement by government.
- ❖ **Divestment** - government surrenders partial ownership and responsibility and sells the majority stake to one or more private entities in course of time.
- ❖ **Displacement** - the private enterprise expands and gradually displaces the government entities. Eg. BSNL and MTNL replaced by private sector.
- ❖ **Disinvestment** - selling a portion of ownership (stake) in a public enterprise to private parties.

### Inward foreign direct investment in India (IFDI)

Foreign direct investment (FDI) may be described as a flow of capital investment to an enterprise in a nation by another enterprise located in a different nation by capturing a majority stake in ownership in a company in the target country or by expanding operations of an existing business in that country.

Where there is no approval through automatic route, the company concerned has to seek permission from **foreign investment facilitation portal (FIFP)**. Few sectors where FDI is prohibited under both the government route as well as the automatic route.

- *Atomic energy*
- *Lottery business*
- *Gambling and betting*
- *Business of chit fund*
- *Nidhi company*
- *Agriculture (excluding floriculture, horticulture, development of seeds, animal husbandry, pisciculture and cultivation of vegetables, mushrooms etc. under controlled conditions and services related to agro and allied sectors) and plantations activities (other than tea plantations)*

## CHAPTER 4 - GOVERNMENT POLICIES FOR BUSINESS GROWTH

---

- *Housing and real estate business (except development of townships, construction of residential/commercial premises, roads or bridges to the extent specified)*
- *Trading in transferable development rights (TDRs)*
- *Manufacturing of cigars, cheroots, cigarillos, of tobacco or of tobacco substitutes.*

### Foreign institutional investors (FII)

- ♣ FII's are large foreign groups with substantial investible funds
- ♣ FII's are registered abroad and invest for short period

### Investment from India abroad (OFDI)

Indian firms invest abroad too. Eg. Bharti Airtel, PVR cinemas, Sun pharma. Data released by RBI show that investments by Indian firms in foreign countries in January 2020 rose by nearly 40% to USD 2.10 billion on a yearly basis.



## CHAPTER 5 - ORGANIZATIONS FACILITATING BUSINESS

---

### Introduction

**Business facilitators** as a system of arrangements that ease the doing of business. Business facilitator is defined as intermediary in financial sector. Business facilitator help the business in several ways some of them are:

- ✦ **Freight forwarder** - a person or company who organizes shipments for the business firms to get goods from the manufacturer or producer to a market, customer or final point of distribution.
- ✦ **Business incubator** - helps create and grow young businesses by providing them with necessary support and financial and technical services.
- ✦ **Financial accelerator** - helps a budding business quickly launch a product and put in the fast lane of commercial success.
- ✦ **Financial consultant** - who advises the business on the various sources of finance-domestic as well as foreign; debt as well as equity; short-term as well as long-term and helps it mobilise its requirement too.
- ✦ **Merchandiser** - who helps the business.

### Non-funding institutions for business facilitation in India (India regulatory bodies)

#### Reserve bank of India (RBI)

##### Introduction

- ♣ *RBI was established on 1<sup>st</sup> April, 1935 in accordance with the provisions of RBI Act, 1934.*
- ♣ *Nationalisation in 1949*
- ♣ *Rbi fully owned by government*
- ♣ *Central office in Mumbai*

##### Role of RBI

- ♣ *Apex monetary institution*
- ♣ *Maintenance of economic stability and assisting the growth*
- ♣ *Controlling the country's monetary policy*
- ♣ *Advisor to the government*
- ♣ *Act as a friend, philosopher and guide to commercial banks*
- ♣ *RBI keep inflationary trends under control*
- ♣ *Protect the market for government securities*

##### Function of RBI

- ♥ **Issue of currency** - not one rupee coins and notes and subsidiary coins
- ♥ **Banker to the government** -
  - *Transact all the general banking business of SG and CG*
  - *Manages public debt*
  - *Treasury bills on behalf of CG*
  - *Advances for 90 days to CG & SG*
  - *Act as an advisor to government*

## CHAPTER 5 - ORGANIZATIONS FACILITATING BUSINESS

---

- ♥ **Banker's bank** - control and supervise commercial banking system
- ♥ **Custodian of foreign exchange reserves**
- ♥ **Control of credit**
- ♥ **Promotional functions** - promoting banking habit among people and mobilising savings from every corner of the country
- ♥ **Collection and publication of data**

### RBI's role in business facilitation

- Currency policy
- Credit policy
  - ◆ Statutory liquidity ratio (SLR), Cash reserve ratio (CRR) or Bank rate are quantitative measures of credit policy
  - ◆ **Discount rate** - RBI provides loans to the banks either by direct lending or by rediscounting (buying back) the bills of commercial banks and treasury bills.
  - ◆ **Repo rate** - the rate at which banks borrow money from the RBI against pledging or sale of government securities to RBI
  - ◆ **Reverse repo rate** - it is the rate of interest offered by RBI, when banks deposits their surplus funds with RBI for short periods.
- Development of the financial system
- Fund transfer and payment mechanism

### Securities and Exchange Board of India (SEBI)

#### Introduction

- ✓ *Established by the government of India on 12<sup>th</sup> April 1988*
- ✓ *SEBI act, 1992 has come into force with effect from 30<sup>th</sup> January, 1992*
- ✓ *Headquarters at district of Bandra Kurla complex in Mumbai.*
- ✓ *SEBI consists of chairman, two members from ministry, one member from RBI, five other members out of which three members shall be whole time.*

#### Functions and responsibility of SEBI

SEBI has to be responsive to the needs of three groups,

- ✚ The issuers of securities
- ✚ The investors
- ✚ The market intermediaries

SEBI has three functions

- ❖ **Quasi-legislative** - draft regulation
- ❖ **Quasi-judicial** - passes ruling and orders
- ❖ **Quasi-executive** - conduct investigation and enforcement

There is securities appellate tribunal consists of three members which is headed by Mr. Justice J P Devadhar.

#### Powers of SEBI

- ♣ Approve by-laws of stock exchange

## CHAPTER 5 - ORGANIZATIONS FACILITATING BUSINESS

---

- ♣ Require stock exchange to amend their bye-laws
- ♣ Inspect the books of accounts and call for periodical return from stock exchange
- ♣ Inspect books of financial intermediary
- ♣ Compel certain companies to list their shares in one or more stock exchange

### SEBI's role in business facilitation

Enables firm to raise funds in the capital market and causes them to institute effective mechanisms of corporate governance.

### Competition Commission of India (CCI)

Competition commission was set up to create and sustain fair competition in the economy that will provide a 'level playing field' to the producers and make the markets work for the welfare of the consumers

- i. **Direct competition** - product that performs the same function compete against each other. Eg. Coca-cola and pepsi
- ii. **Indirect competition** - products that are close substitute for one another compete. eg. fine dining restaurant with local restaurant

### Benefits of free and fair competition

- ◆ Encourages innovations
- ◆ Increases efficiency
- ◆ Punishes the laggards
- ◆ Boosts choice improves quality, reduces costs
- ◆ Ensures availability of goods in abundance of acceptable quality in affordable price.

### Features of Competition Act, 2002

- ♥ Prevent practices having appreciable adverse effect on competition
- ♥ Promote and sustain competition
- ♥ Protect interest of consumers
- ♥ Ensures freedom of trade

### The Competition Commission of India (CCI)

- × Established by CG on 14<sup>th</sup> October 2003
- × Chairman and six members

### Objectives of CCI

- To prevent practices having adverse effect on competition
- To promote and sustain competition in markets
- To protect the interest of consumers and,
- Ensure freedom of trade

### Role of CCI

- Work for the benefit and welfare of consumers

## CHAPTER 5 - ORGANIZATIONS FACILITATING BUSINESS

---

- Fair and healthy competition
- Implement competition policies
- Develop and nurture effective relations and interactions with sectoral regulations
- Effectively carry out competition advocacy and spread the information

### Role of CCI as business facilitator

- ♣ Ensures co-existence of large and small enterprises
- ♣ Prevents misuse of dominant position in the market against other business

### Insurance Regulatory and Development Authority of India (IRDAI)

#### Introduction

- Is an autonomous apex statutory body
- IRDAI act, 1999

#### Mission statement of the authority

- ✚ To protect the interest of and secure fair treatment to policy holders
- ✚ Speedy and orderly growth of the insurance industry
- ✚ To set, promote, monitor and enforce high standards of integrity, financial soundness, fair dealing and competence
- ✚ To ensure speedy settlement of genuine claims, to prevent insurance frauds and other malpractices
- ✚ To promote fairness, transparency and orderly conduct in financial markets dealing with insurance
- ✚ To take action where standards are inadequate or ineffectively enforced
- ✚ Optimum amount of self-regulation

#### Duties, powers and functions of IRDAI

- ♣ Issue to the applicant a certificate of registration, renew, modify, withdraw, suspend or cancel such registration
- ♣ Protection of the interest of the policy holders
- ♣ Specifying requisite qualifications, code of conduct and practical training for intermediary
- ♣ Code of conduct for surveyors and loss assessors
- ♣ Promoting efficiency in business
- ♣ Promoting and regulating professional organisation connected with insurance
- ♣ Laying fees or other charges
- ♣ Calling for information, enquiry and investigation
- ♣ Control and regulation of rates, advantages, terms and conditions
- ♣ Specify the form and manner of books of accounts and statement of accounts
- ♣ Regulating investment of funds
- ♣ Regulating maintenance of margin of solvency
- ♣ Adjudication of dispute between insurers and intermediaries

## CHAPTER 5 - ORGANIZATIONS FACILITATING BUSINESS

---

- ♣ Supervising the functioning of the tariff advisory committee
- ♣ Specify the percentage of premium income
- ♣ Specify the percentage of life insurance and general insurance business
- ♣ Exercising such other powers as may be prescribed

### Role of IRDAI as a Business facilitator

Insurance is an important aid to business and IRDA ensures that this important service efficiently enables transfer of business risks.

### Funding institutions (Indian Development Banks)

- ✚ Need for day to day operations (working capital)
- ✚ Need for finance for undertaking (CAPEX)
- ✚ Industrial Finance Corporation of India (IFCI) in 1948
- ✚ Industrial Credit and Investment Corporation of India (ICICI) in 1955
- ✚ Industries Development Bank of India (IDBI) in 1964

### National Bank for Agriculture and Rural Development (NABARD)

- ♣ Apex development bank in India
- ♣ Headquarters at Mumbai
- ♣ Bank is entrusted with "matters concerning policy, planning and operations in the field of credit for agriculture and other economic activities in rural areas in India".
- ♣ NABARD discharge its duty -
  - Serves as an apex funding agency
  - Takes measures towards institutions buildings for improving absorptive capacity of the credit delivery system, including monitoring, formulation of rehabilitation schemes, restructuring credit institutions, training of personnel etc.
  - Co-ordinates the rural financing activities and maintain liaison with govt. of India, RBI and other national level institutions
  - Undertake monitoring and evaluation of projects refinanced by it
  - NABARD's refinance is available to state co-operative agriculture and rural development banks (SCARDBs), state co-operative bank(SCBs), regional rural bank (RRBs), commercial bank (CBs)
  - NABARD is also known for its 'SHG Bank Linkage Programme'

## CHAPTER 6 – COMMON BUSINESS TERMINOLOGIES

---

### BUSINESS - many facets of the same reality

- + **Technical facet** - technically a business may be viewed as a transformation process - a huge machine - where in inputs are subjected to the entire process for generating output
- + **Commercial facet** - commercially, business is all about marketing management, that is, planning, organising, directing and controlling a firm's relationships with its customers/markets.
- + **Financial facet** - from an economic, accounting and financial perspective, business implies investment and the associated returns and risks.
- + **HR facet** - from a HR perspective, a business organisation is all about people occupying different job positions and performing their respective roles, responsibilities and functions.
- + **Administrative facet** - administratively, BCK pertains to the forms of business organisation, regulations, approvals and clearances needed to start and carry a business.

### FINANCE, STOCK AND COMMODITY MARKET TERMINOLOGY

- ♥ **Agent** - A brokerage firm is said to be an agent when it acts on behalf of the client in buying or purchasing of shares.
- ♥ **Amortize** - to amortize is to charge a regular portion of an expenditure over a fixed period of time.
- ♥ **Annuity due** - an annuity whose payments occur at the beginning of each period
- ♥ **Annuity** - a series of payments of an equal amount at fixed intervals for a specified number of periods
- ♥ **Appreciation** - appreciation is an increase in value
- ♥ **Arbitrage** - arbitrage is the simultaneous purchase and sale of two identical commodities or instruments
- ♥ **Asset** - asset means an economic resources that is expected to be of benefit in the future.
  - Current assets - current assets are those assets that can be expected to turn into cash within a year or less.
  - Fixed assets - fixed assets cannot be quickly turned into cash without interfering with business operations
  - Intangible assets - intangible assets are items such as patents, copyrights, trademarks, and other kind of things or rights of value to a company, which are not physical objects
- ♥ **Ask/offer** - the lowest price at which an owner is willing to sell his securities. The offer is higher than the bid
- ♥ **Audit** - audit is a careful review of financial records of an organization to verify their accuracy

## CHAPTER 6 – COMMON BUSINESS TERMINOLOGIES

---

- ♥ **Bad debts** - bad debt are amounts owed to a company that are not going to be paid.
- ♥ **Balance sheet** - Balance sheet is a statement of the financial position of a company at a single specific time.
- ♥ **Bond** - bond is a type of long-term promissory note. It is a written record of a debt payable in the future.
- ♥ **Book value** - Total assets minus total liabilities means book value of shareholder's equity. Book value also means the value of an asset as recorded on the company's books or financial reports.
- ♥ **Breakeven point** - it is the amount of revenue from sales which exactly equals the amount of expenses.
- ♥ **Budget** - budget is the detailed plan for the future, usually expressed in formal quantitative terms.
- ♥ **Bears** - these stock-market players are pessimists, they expect share price or any other type of investment to fall.
- ♥ **Base price** - this is the price of a security at the beginning of the trading day
- ♥ **Basket trading** - basket trading is a facility by which investors are in a position to buy/sell all 30 scrips of sensex in the proportion of current weights in the sensex, in one go.
- ♥ **Bear market** - a market in which prices are falling consistently
- ♥ **Badla** - carrying forward of transaction form one settlement period to the next without effecting delivery or payment. A badla transaction attracts the following payments/charges:
  - Margin money and
  - Contango or badla charges (interest charges) determined on the basis of demand and supply
- ♥ **Blue chips** - blue chips are shares of large, well established and financially sound companies with an impressive record of earnings and dividends.
- ♥ **Beta** - it is a measurement of relationship between stock price of any particular stock and movement of whole market
- ♥ **Bid** - it is the highest price a buyer is willing to pay for a stock.
- ♥ **Broker/brokerage firm** - a registered securities firm are called broker/brokerage firm. They charge commission for their service
- ♥ **Bull market** - a market in which the stock price is increasing consistently
- ♥ **Business day** - days on which stock markets are open. Monday to Friday, excluding public holidays.
- ♥ **Bonus** - a free allotment of shares made in proportion to existing shares out of accumulated reserves.
- ♥ **Book closure** - dates between which a company keeps its register of members closed for updating prior to payment of dividends or issue of new shares or debentures.
- ♥ **Brokerage** - brokerage is the commission charged by the broker

## CHAPTER 6 – COMMON BUSINESS TERMINOLOGIES

---

- ♥ **Bull** - a bull is one who expects a rise in price so that he can later sell at higher price
- ♥ **Business risk** - the riskiness inherent in the firm's operations is it uses no debt
- ♥ **Buyer** - the trading member who have placed the order for the purchase of the securities.
- ♥ **Call option** - an option given to investor the right but not obligation to buy a particular stock at a specified price within a specified time period.
- ♥ **Capital budgeting** - the process of planning expenditure on assets whose cash flows are expected to extend beyond one year.
- ♥ **Capital gain yield** - the capital gain during a given year divided by the beginning price
- ♥ **Capital market** - the financial markets for stocks and for intermediate or long term debt
- ♥ **Cash budget** - a table showing cash flows (receipt, disbursement, and cash balances) for a firm over a specified period
- ♥ **Credit period** - the length of time for which credit is granted
- ♥ **Closing price** - the trade price of a security at the end of a trading day
- ♥ **Commercial paper** - unsecured, short term promissory notes of large firms, usually issued in denominations of ₹1,00,000 or more and having an interest rate somewhat below the prime rate of lending rate of commercial bank
- ♥ **Commodities** - product used for commerce that are traded on a separate, authorized commodities platform.
- ♥ **Convertible securities** - a security (bond, debentures, preferred stocks) by an issuer that can be converted into other securities of that issuer are known as convertible securities.
- ♥ **Consolidation** - business combination of two or more entities that occurs when the entities transfer all of their net assets to a new entity created for that purpose
- ♥ **Creditors** - these are people/organization you owe money to at any particular time
- ♥ **Debentures** - a type of debt instrument that is not secured by physical assets or collateral.
- ♥ **Debtors** - a debtor is a company or individual who owes money
- ♥ **Defensive stock** - a stock that provides a constant dividends and stable earnings even in the period of economic downturn.
- ♥ **Depreciation** - depreciation is a way of spreading the cost of an asset over its expected useful economic life.
- ♥ **Derivates** - a security whose price is derived from one or more underlying assets.
- ♥ **Diversification** - reducing the investment risk by purchasing shares of different companies operating in different sectors



## CHAPTER 6 – COMMON BUSINESS TERMINOLOGIES

---

- ♥ **Dividend** - a portion of the company's earning decided to pay to its shareholders in return to their investments.
- ♥ **Equity (net worth)** - the capital supplied by common stock holders common stock, paid-up-capital, retained earnings, and occasionally, certain reserves. Total equity is common equity plus preferred stock
- ♥ **Exchange rate** - the number of units of given currency that can be purchased for one unit of another currency
- ♥ **Face value** - it is the cash denomination or the amount of money the holder of the individual security going to earn from the issuer of the security at the time of maturity. It is also known as par value.
- ♥ **Financial instrument** - A financial instrument is anything that ranges from cash, deed, negotiable instrument, or for that matter any written and authenticated evidence that shows the existence of a transaction or agreement.
- ♥ **Financial intermediary** - A financial intermediary is basically a party or person who acts as a link between a provider who provides securities and the user, who purchases the securities.
- ♥ **Government bonds** - A government bond, which is also known as a government security, is basically any security that is held with the government and has the highest possible rate of interest
- ♥ **Hedge** - Hedge is a strategy that is used to minimize the risk of a particular investment and maximize the return of an investment.
- ♥ **Holding period** - the holding period is the time duration during which a capital asset is held/owned by an individual or corporation.
- ♥ **Income stock** - a security which has a solid record of dividend payments and offers the dividend higher than the common stock
- ♥ **Index** - a statistical measurement of change in the economy or security market.
- ♥ **Initial public offering (IPO)** - a company's first issue of shares to general public
- ♥ **Internet trading** - internet trading is a platform with internet as a medium.
- ♥ **Limit order** - An order to buy or sell a share at a specified price.
- ♥ **Liquidation** - A liquidation occurs when the assets of a division are sold off piecemeal, rather than as an operating entity.
- ♥ **Listed stocks** - the shares of a company that are traded on the stock exchange.
- ♥ **Market capitalization** - the total value in rupee of all of a company's outstanding shares.
- ♥ **Money market** - money market is component of financial market for asset involved in short term borrowing, lending, buying and selling with original maturities of one year or less.
- ♥ **Mutual fund** - A pool of money managed by experts by investing in stocks, bonds and other securities with the objective of improving their savings.

## CHAPTER 6 – COMMON BUSINESS TERMINOLOGIES

---

- ♥ **One-sided market** - A market that has only potential sellers or only potential buyers but not both.
- ♥ **Out of money (OTM)** - for call options, this means the stock price is below the strike price. For put options, this means the stock price is above the strike price.
- ♥ **Portfolio** - holding of any individual or institution. A portfolio may include various type of securities of different companies operating in different sectors.
- ♥ **Pre-opening sessions** - the pre open session is for duration of 15min i.e from 9:00 am to 9:15 am.
- ♥ **Price earning (P/E) ratio** - the market price of a share of stock dividend by the earnings (profit) per share.
- ♥ **Put option** - an option that gives an investor the right to sell a particular stock at a stated price within a specified time period.
- ♥ **Return on investment (ROI)** - ROI is a measure of the effectiveness and efficiency with which managers use the resources available to them, expressed as a percentage.
- ♥ **Risk** - a probable chances of investments actual returns will be reduced then as calculated.
- ♥ **Securities** - a transferable certificate of ownership of investment in products such as stocks, bonds, future contracts and options which an individual holds.
- ♥ **Strike price** - the price at which the holder of an option can buy (in case of call option) or sell (in case of put option) the securities they hold when the option is executed.
- ♥ **Stock** - a certificate (or electronic or other record) that indicates ownership of a portion of a corporation; a share of stock. Stock also means the stock of goods, the stock on hand, the inventory of a company.
- ♥ **Thin market** - a market in which there are comparatively low number of bids to buy and offers to sell.
- ♥ **Trading session** - the period of time stock market is open for trading for both sellers and buyers, within this time frame all the orders of the day must be placed (9:15 am to 3:30 pm) here all the orders placed in pre-opening sessions are matched and executed.
- ♥ **Venture capital** - venture capital is a form of private and a type of financing that investors provide to startup companies and small business that are believed to have long term growth potential.
- ♥ **Yield** - it is the measure of return on investments in terms of percentage.
- ♥ **Yield to call (YTC)** - the rate of return earned on a bond if it is called before its maturity date.
- ♥ **Zero coupon bond** - a bond that pays no annual interest but is sold at a discount below par, thus providing compensation to investors in the form of capital appreciation.

## CHAPTER 6 – COMMON BUSINESS TERMINOLOGIES

---

### MARKETING TERMINOLOGY

- ❖ **Advertising campaign** - an organization's programme of advertising activities over a particular period with specific aims.
- ❖ **Advertising** - advertising is any paid form of non-personal presentation and promotion of ideas, goods and services through mass media such as newspaper, magazines, television or radio by an identified sponsor.
- ❖ **After sales service** - the services received after the original goods or services have been paid for.
- ❖ **Agent** - agent is a part of the distribution channel.
- ❖ **Barrier to trade** - something that makes trade between two countries more difficult or expensive
- ❖ **Barriers to entry/exit** - economic or other characteristics of a marketplace that makes it difficult for new firms to enter or exit.
- ❖ **Benchmarking** - benchmarking is the process of comparing the products and services of a business against those of competitors in a market, or leading businesses in other markets, in order to find ways of improving quality and performance.
- ❖ **Brand** - a brand-represented by a brand name, symbol, design, logo, packaging- is the identity of a particular product form that customers recognise as being different from others.
- ❖ **Brand equity** - brand equity refers to the value of brand.
- ❖ **Brand loyalty** - it is a strongly motivated and long standing decision of the customer to purchase a particular product or service.
- ❖ **Brand recognition** - it is a customer's awareness that a brand exists and is an alternative to purchase.
- ❖ **Business model** - a company's business model is management's storyline for how the strategy will be a money maker.
- ❖ **Business portfolio** - the business portfolio is the collection of businesses and products that make up the business.
- ❖ **Business to business** - marketing activity directed from one business to another.
- ❖ **Buying behaviour** - buying behaviour concerns the process that buyers go through when deciding whether or not to purchase goods or services.
- ❖ **Cash discount** - a reduction in the price of goods given to encourage sale on cash basis.
- ❖ **Competitive advantage** - advantages that a firm has over its competitors.
- ❖ **Competitive position** - the position that a firm has or wishes to achieve within its industry as measured against its competition.
- ❖ **Conglomerate diversification** - a strategy of growing a firm by acquiring other firms for investment purposes; usually little or no anticipated synergy with the acquired firm.

## CHAPTER 6 – COMMON BUSINESS TERMINOLOGIES

---

- ♣ **Consortium** - consortium is a combination of several companies working together for a particular purpose.
- ♣ **Consumer markets** - consumer market are the markets for products and services bought by individual for their own or family use.
- ♣ **Corporate culture** - corporate culture refers to a company's values, beliefs, business principles, traditions, ways of operating, and internal work environment.
- ♣ **Cross selling** - using a customer's buying history to select them for related offers.
- ♣ **Customer demand** - customer demand is a want for specific product supported by an ability and willingness to pay for it.
- ♣ **Customer loyalty** - feeling or attitude that inclined a customer either to return to a company, shop or outlet to purchase there again, or else to re-purchase a particular product, service or brand.
- ♣ **Customer need** - a need is a basic requirement that an individual wishes to satisfy
- ♣ **Customer satisfaction** - the provision of goods or services which fulfil the customer's expectation in terms of quality and service, in relation to price paid.
- ♣ **Customer want** - a want is a desire for a specific product or service to satisfy the underlying need.
- ♣ **Differentiation** - a marketing strategy aimed at ensuring that products and services have a unique element to allow them to stand out from the rest.
- ♣ **Direct marketing** - when businesses and non-profit organization market their products, services or causes directly to consumers based on consumer interest.
- ♣ **Distribution Channel** - The network of organisations necessary to distribute goods or services from manufacturers to the consumers; the distribution channel therefore potentially consists of manufacturers, distributors, wholesalers, retailers and E-tailers.
- ♣ **Diversify** - A company, increases the range of goods or services it produces and sells.
- ♣ **E-Commerce** - The use of technologies such as the Internet, electronic data exchange and industry extranets streamline business transactions.
- ♣ **Economy of Scale** - A reduction in costs through larger operating units, spreading fixed costs over large numbers of items/units.
- ♣ **External Environment** - The conditions and forces that define a firm's competitive position and influences its strategic options. Also, called Competitive Environment.
- ♣ **Fast-Moving Consumer Goods (FMCG)** - Fast-moving consumer goods are those that sell in high volumes, with low unit value, and have fast consumer repurchase.

## CHAPTER 6 – COMMON BUSINESS TERMINOLOGIES

---

- ♣ **Forecasting** - The process of estimating future demands by anticipating what buyers are likely to do under a given set of marketing conditions.
- ♣ **Innovators** - Innovators are those who adopt new products first.
- ♣ **Internal Marketing** - The process of eliciting support for a company and its activities among its own employees, in order to encourage them to promote its goals.
- ♣ **Joint Venture** - A third party commercial operation established by two or more firms to pursue a particular market, resource supply, or other business opportunity.
- ♣ **Long-Term Objectives** - A firm's intended performance over a multi-year period of time; usually includes measures such as competitive position, profitability, return on investment, technology leadership, productivity, employee relations and development, public responsibility.
- ♣ **Market Development** - The process of growing sales by offering existing products (or new versions of them) to new customer groups.
- ♣ **Market Entry** - The launch of a new product into a new or existing market.
- ♣ **Market Leader** - The company that has control over a certain market.
- ♣ **Market Positioning** - A marketing strategy that will position a business products and services against those of its competitors in the minds of consumers.
- ♣ **Market Research** - The systematic gathering, recording and analysing of data about problems relating to the marketing of goods and services.
- ♣ **Market Segmentation** - Dividing consumers into groups based on different consumer characteristics, to deliver specially designed advertisements that meet these characteristics as closely as possible.
- ♣ **Market Share** - Market share can be defined as the percentage of all sales within a market that is held by one brand/ product or company.
- ♣ **Market Targeting** - Market targeting is the process of evaluating each market segment and selecting the most attractive segments to enter with a particular product or product line.
- ♣ **Marketing** - Marketing is the science and art of exploring, creating and delivering value to satisfy the needs of a target market at a profit. Marketing identifies unfulfilled needs and desires.
- ♣ **Marketing Mix** - It refers to the firm's marketing elements. It is common to describe these elements in terms of 4Ps of marketing, viz., Product, Price, Place and Promotion. For services marketing usually three additional Ps are referred to, viz, People, Processes and Physical Evidence.
- ♣ **Marketing Plan** - A detailed statement (usually prepared annually) of how a company's marketing mix will be used to achieve its market objectives.
- ♣ **Mass Marketing** - When many consumers receive the same message from businesses and non-profit organizations through mass media, such as broadcast television, radio and newspapers, regardless of consumer interests.

## CHAPTER 6 – COMMON BUSINESS TERMINOLOGIES

---

- ♣ **Merger** - Merger is considered to be a process when two or more companies come together to expand their business operations.
- ♣ **Mission** - The unique purpose of a firm that sets it apart from firms of its type; identifies scope of operations including markets, customers, products, distribution, technology, etc. in manner that reflects values and priorities of the firm's strategies.
- ♣ **Niche Marketing** - Niche marketing refers to the exploitation of comparatively small market segments by businesses that decide to concentrate their efforts.
- ♣ **Opportunities** - Opportunities are any feature of the external environment which creates conditions that a business can exploit to its advantage.
- ♣ **Personal Selling** - Oral communication with potential buyers of a product with the intention of making a sale.
- ♣ **Pre-Emptive Pricing** - Pre-emptive pricing is a strategy involves setting low prices in order to discourage or deter potential new entrants to the suppliers market.
- ♣ **Price** - The price of a product may be seen as a financial expression of the value of that product.
- ♣ **Price Discrimination** - Price discrimination occurs when a firm charges a different price to different groups of consumers for an identical good or service, for reasons not associated with costs.
- ♣ **Price Elasticity of Demand** - Price elasticity of demand measures the responsiveness of a change in demand for a product following a change in its own price.
- ♣ **Price Sensitivity** - Price sensitivity is the effect a change in price will have on customers.
- ♣ **Price Skimming** - Price skimming involves charging a relatively high price for a short time where a new, innovative, or much-improved product is launched onto a market.
- ♣ **Publicity** - Promotional activities designed to promote a business and its products by obtaining media coverage not paid for by the business.
- ♣ **Sales Promotion** - Sales promotion refers to any activity designed to boost the sales of a product or service.
- ♣ **Short-Term Objectives** - Usually one year objectives sometimes known as Annual Objectives. They often coincide with Long-Term Objectives; they usually indicate the speed at which management wants the organization to progress.
- ♣ **Stakeholder** - A person, group, or business that has an interest in the outcomes of a firm's operations.
- ♣ **Strength** - A skill, resource, or other advantage that a firm has relative to its competitors that is important to serving the needs of customers in its marketplace.

## CHAPTER 6 – COMMON BUSINESS TERMINOLOGIES

---

- ♣ **Target Marketing** - Reaching out to a group of consumers sharing common consumer characteristics with the most appropriate advertisements.
- ♣ **Telemarketing** - Using the telephone to contact individuals about an advertiser's products or services, or to get support for a cause.
- ♣ **Test Marketing** - Test marketing occurs when a new product is tested with a sample of customers, or launched in a restricted geographical area, to judge customers' reactions.
- ♣ **Threats** - Threats are any aspect of the external environment which cause problems and which may prevent achievement of objectives.
- ♣ **Unique Selling Proposition (USP)** - A unique selling proposition is a customer benefit that no other product can claim.
- ♣ **Weakness** - A limitation or lack of skills, resources, or capabilities that impedes a firm's effective performance.
- ♣ **Acceptance** - Acceptance which is also known as the banker's acceptance is a signed instrument of acknowledgment that indicates the approval and acceptance of all terms and conditions of any agreement on behalf of the banker.
- ♣ **Accepting House** - An accepting house is a banking or finance organization that specializes in the service of acceptance and guarantee of bills of exchange.
- ♣ **Accrued Interest** - Accrued Interest is the interest, accumulated on an investment but is not yet paid. Often, accrued interest is also termed as interest receivable.
- ♣ **Administered Rates** - Administered rates are the rates of interest which can be changed contractually by lender.
- ♣ **American Depository Receipt (ADR)** - American depository receipts, also known as ADRS, are depository receipts which are equal to a specific number of shares of company that have been issued in a foreign country.
- ♣ **Annuities** - Annuities are contracts that guarantee income or return, in exchange of a huge sum of money that deposited, either at the same time or is paid with the help of periodic payments.
- ♣ **Automated Clearing House** - An automated clearing house is nation-wide electronic clearing houses that monitors and administers the process of check and fund clearance between banks.
- ♣ **Automated Teller Machines** - Automated teller machines are basically used to conduct transactions with the bank, electronically.
- ♣ **Balance Transfer** - balance transfer is the repayment of a credit debt with the help of another source of credit. In some cases, balance transfer also refers to transfer of funds from one account to another.
- ♣ **Bank Account** - A bank account is an account held by a person with a bank, with the help which the account holder can deposit, safeguard his money, earn interest and also make cheque payments.

## CHAPTER 6 – COMMON BUSINESS TERMINOLOGIES

---

- ♣ **Bank Rate** - It is the interest rate at which the Central Bank in the discharge of its function as Banker's Bank lends to the commercial banks. Since this lending may be in the form of discounting of the securities pledged, it is also called the discount rate.
- ♣ **Basis Point** - It is a measure of change in financial parameters such as interest, stock indices and market rates. It is 1/100 of one percent.
- ♣ **Bounced Cheque** - A bounced cheque is nothing but an ordinary bank cheque that any bank can refuse to encash or pay because of the fact that there are no sufficient finances in the bank account of the originator or drawer of the cheque or some other valid reason.
- ♣ **Bridge Financing** - Also, known as gap financing, bridge financing is a loan where the time and cash flow between a short term loan and a long term loan is filled up. Bridge financing begins at the end of the time period of the first loan and ends with the start of the time period of the second loan, thereby bridging the gap between two loans. It is also known as gap financing.
- ♣ **Cap** - A cap is a limit that regulates the increase or decrease in the rate of interest and installments of an adjustable rate mortgage.
- ♣ **Cashier's Cheque** - The cashier's cheque is drawn by a bank on its own name to make payments to other organizations, banks, corporations or even individuals.
- ♣ **Cash Reserve** - The cash reserve is the total amount of cash that is present in the bank account and can also be withdrawn immediately.
- ♣ **Certificate of Deposit** - The certificate of deposit is a certificate of savings deposit that promises the depositor the sum back along with appropriate interest.
- ♣ **Cheque** - A cheque is a negotiable instrument that instructs the bank to pay a particular amount of money from the writer's bank, to the receiver of the cheque.
- ♣ **Clearing** - Clearing of a cheque is basically a function that is executed at the clearing house, when all amount of the cheque is subtracted from the payer's account and then added to the payee's account.
- ♣ **Clearing House** - The clearing house is a place where the representatives of the different banks meet for confirming and clearing all the checks and balances with each other. The clearing house, in most countries across the world, is managed by the central bank.
- ♣ **Compound Interest** - Compound interest is the interest that is 'compounded on a sum of money that is deposited.
- ♣ **Debit Card** - A consumer makes that payment first to the credit card company and then swipes the card. The debit card operates in the exact opposite manner of the credit card.
- ♣ **Deposit Slip** - A deposit slip is a bill of itemized nature and depicts the amount of paper money, coins and the check numbers that are being deposited into a bank account.



## CHAPTER 6 – COMMON BUSINESS TERMINOLOGIES

---

- ❖ **Depositor** - The person who deposits money into a bank account is called a depositor.
- ❖ **Debt Settlement** - Debt settlement is a procedure wherein a person in debt negotiates the price with the lender of a loan, in order to reduce the installments and the rate of repayment, and ensure a fast and guaranteed repayment.
- ❖ **Debt Repayment** - Debt repayment is the total process repayment of a debt along with the interest. Sometimes, the consolidation that is provided is also included in debt repayment.
- ❖ **Debt Recovery** - Debt recovery is the process that is initiated by the banks and lending institutions, by various procedures like debt settlement or selling of collaterals.
- ❖ **E-Cash** - Also known as electronic cash and digital cash, e-cash is a technology where the banking organizations resort to the use of electronic, computer, internet and other networks to execute transactions and transfer funds.
- ❖ **Early Withdrawal Penalty** - An early withdrawal penalty is basically a penalty that is levied by a bank because of an early withdrawal of a fixed investment by any investor.
- ❖ **Earnest Money Deposit** - An earnest money deposit is made by the buyer to the potential seller of a real estate, in the initial stages of negotiation of purchase.
- ❖ **Expiration Date** - This term indicates the invalidity of a financial document or instrument, after a specified period of time.
- ❖ **Education Loan** - An education loan, also known as student's loan, is specifically meant to provide forth borrower's expenditure towards education.
- ❖ **Guarantor** - A guarantor is a creator of trust who takes the responsibility of the repayment of a loan, and is also, in some cases, liable and equally responsible for the repayment of the loan.
- ❖ **Installment Contract** - An installment contract is a contract where the borrower, who is also the purchaser, pays a series of installments that includes the interest of the principal amount.
- ❖ **Interest / Interest Rate** - Interest is a charge that is paid by any borrower or debtor for the use of money, which is calculated on the basis of the rate of interest, time period of the debt and the principal amount that was borrowed. Interest is, sometimes, also titled as the 'cost of credit'.
- ❖ **Internet Banking** - Internet banking is a system wherein customers can conduct their transactions through the Internet. This kind of banking is also known as e-banking or online banking.
- ❖ **Letter of Credit** - A document issued by a bank (on behalf of the buyer or the importer), stating its commitment to pay a third party (seller or the exporter),

## CHAPTER 6 – COMMON BUSINESS TERMINOLOGIES

---

a specific amount, for the purchase of goods by its customer, who is the buyer.

- ♣ **Lock-in Period** - A guarantee given by the lender that there will be no change in the quoted mortgage rates for a specified period of time, which is called the lock-in period.
- ♣ **Mortgage** - A mortgage is a legal agreement between the lender and the borrower where real estate property is used as collateral for the loan, in order to secure the payment of the debt.
- ♣ **Maturity** - The term maturity is used to indicate the end of investment period of any fixed investment or security.
- ♣ **Market Value** - Market value is the value at which the demand of consumers and the supply of the manufacturers decide the price of a commodity or service.
- ♣ **Online Banking** - The accessing of bank information, accounts and transactions with the help of a computer through the financial institution's website on the Internet is called online banking. It is also called Internet banking or e-banking.
- ♣ **Overdraft** - It is a check or rather an amount of check, which is above the balance available in the account of the payer.
- ♣ **Payee** - Payee is the person to whom the money is to be paid by the payer.
- ♣ **Payer** - Payer is the person who pays the money to the payee.
- ♣ **Personal Identification Number (PIN)** - Personal identification number or PIN is a secret code of numbers and alphabets given to customers to perform transactions through an automatic teller machine or an ATM.
- ♣ **Repo Rate** - The rate at which banks borrow money from the RBI against pledging or sale of government securities to RBI is known as "Repo Rate." Repo rate is short form of Repurchase Rate. Generally, these loans are for short durations up to 2 weeks. Repo Rate differs from Bank Rate with respect to the time horizon. Repo Rate is a short-term measure and it refers to short-term loans. On the other hand, Bank Rate is a long term measure and is governed by the long-term monetary policies of the RBI.
- ♣ **Reverse Repo Rate** - It is the rate of interest offered by RBI, when banks deposit their surplus funds with the RBI for short periods.
- ♣ **Smart Cards** - Unlike debit and credit cards (with magnetic stripes), smart cards possess a computer chip, which is used for data storage, processing and identification.
- ♣ **Syndicated Loan** - A very large loan extended by a group of small banks to a single borrower, especially corporate borrowers. In most cases of syndicated loans, there will be a lead bank, which provides a part of the loan and syndicates the balance amount to other banks.
- ♣ **Time Deposit** - A kind of bank deposit which the investor is not able to withdraw, before a time fixed when making the deposit.

## CHAPTER 6 – COMMON BUSINESS TERMINOLOGIES

---

- ❖ **Value At Risk (VAR)** - The sum or portion of the value that is at stake of subject to loss from a variation in prevalent interest rates.
- ❖ **Wholesale Banking** - Wholesale banking is a term used for banks which offer services to other corporate entities, large institutions and other financial institutions.
- ❖ **Zero Balance Account** - A bank account which does not require any minimum balance is termed as a zero balance account.
- ❖ **Zero-Down-Payment Mortgage** - Zero-down-payment mortgage is a type of mortgage given to a buyer who does not make any down payments while borrowing. The mortgage buyer borrows the amount at the entire purchase price. For example, Jaan Dhan Account.

### OTHER BUSINESS TERMINOLOGY

- ❖ **Acquisition** - When one organization takes over the other organization and controls all its business operations, it is known as acquisitions.
- ❖ **Bankruptcy** - A bankruptcy refers to economic insolvency, wherein the person's assets are liquidated, to pay off all liabilities with the help of a bankruptcy trustee or a court of law.
- ❖ **Bottom-Line** - In plain english bottom line means the most important fact or aspect of anything. In BCK, it may be defined as the firm's income after all expenses have been deducted from revenues. These expenses include interest charges paid on loans, general and administrative costs and income taxes. In simpler words, it is the same thing as Net Profits for these mattered the most for the owners of the firm.
- ❖ **Business Environment** - It is a set of all the variables external to the firm but influence its decision-making and in turn are also influenced by it.
- ❖ **Business Facilitators** - These are individuals, organisations/ institutions and all other arrangements that ease the setting up of, operating and exiting from business.
- ❖ **Corporate Forms of Business Organisation** - These are the forms of business organisation where in the eyes of law the business entity is distinct from its owners.
- ❖ **Corporate Governance** - It is a system of overseeing the affairs of a corporation to ensure that they are conducted in an ethical manner and as per provisions of law. The mechanism of corporate governance includes the board of directors who appoint, oversee and reward the management team; (b) independent audit of the accounts of the company; (c) reporting of the performance to the markets (stock exchanges) and business media. All these are examples of the system of corporate governance.
- ❖ **Electronic Commerce** - It broadly refers to the Internet and mobile telephony based applications for conducting business and commerce. The latter more precisely is known as mobile commerce.

## CHAPTER 6 – COMMON BUSINESS TERMINOLOGIES

---

- ❖ **Electronic Filing** - Electronic filing is system of filing information required by regulators, government and others electronically.
- ❖ **Globalisation** - It is a systematic process of removing the barriers to international trade in goods and services and the international flows of capital.
- ❖ **Goodwill** - Goodwill in accounting is the difference between what a company pays when it buys the assets of another company and the book value of those assets.
- ❖ **Infrastructure** - It means the basic facilities e.g. buildings, roads, power supplies needed for the operation of a society or enterprise.
- ❖ **Joint Products and By-Products** - Joint products represent "two or more products separated in the course of the same processing operation, usually requiring further processing each product being in such proportion that no single product can be designed as a major product". By-products are defined as "products recovered from material discarded in a main process, or from the production of some major products, where the material value is to be considered at the time of severance from the main product". Thus, by-products emerge as a result of processing operation of another product or they are produced from the scrap or waste of materials of a process. For example, molasses in sugar industry.
- ❖ **Liberalisation** - It refers to a systematic process of easing of government's control over the private business activity.
- ❖ **Logistics** - It is a commercial activity implying moving of supplies to the production facilities and goods and services to their respective markets. Inbound logistics imply the movement of inputs and the outbound logistics means the movement of outputs.
- ❖ **Merger** - When two or more companies come together to increase their strength and financial gains along with breaking the trade barriers in a newly created entity.
- ❖ **Mission** - A company's Mission statement is typically focused on its present business scope - who we are and what we do mission statements broadly describe an organizations present capabilities, customer focus activities, and business makeup.
- ❖ **PESTLE** - It is a mnemonic i.e. a pattern of letters that helps in remembering the various elements of the macro environment of business.
- ❖ **Privatisation** - It is a systematic process of dispensing with the state ownership of business enterprises. One way of doing this could be by way of listing the shares of public corporations on the stock exchanges.
- ❖ **Proprietary Forms of Business Organisations** - These are the forms of business organisation where the law does not distinguish between the business as a separate entity distinct from its owners.
- ❖ **Returns and Risks** - These are the two sides of the business's outcomes particularly for its owners and generally for all investments.

## CHAPTER 6 – COMMON BUSINESS TERMINOLOGIES

---

- ❖ **Sustainable Development** - Sustainable development (SD) is a broader measure of the development of a country that includes economic parameters such as income and non-economic parameters such as social equity and ecological balance.
- ❖ **Term Insurance** - It is the insurance for a certain time period which provides for no defrayal to the insured individual, excluding losses during the period, and that becomes null upon its expiration.
- ❖ **Triple Bottom Line (TBL)** - It is the BCK philosophy that promotes the belief and evaluates the business's performance on the basis that attainment of profit, care for people and care for the planet are equally important. The equal emphasis on these triple Ps, viz., Profits, People and Planet is known as the TBL. This idea at the macro level corresponds to the more evolved notion of the development of a country's economy, society and ecology. See sustainable development.
- ❖ **Turnaround** - A turnaround is the financial recovery of a company that has been performing poorly for an extended time. To effect a turnaround, a company must acknowledge and identify its problems, consider changes in management, and develop and implement a problem-solving strategy.
- ❖ **Vision** - A Strategic vision is a road map a company's future providing specifics about technology and customer focus, the geographic and product markets to be pursued, the capabilities it plans to develop, and the kind of company that management is trying to create.
- ❖ **Whole Life Insurance** - A whole life insurance is a contract between the insurer and the policy owner, that the insurer will pay the sum of money on the occurrence of the event mentioned in the policy to the insured. It's a concept wherein the insurer mitigates the loss caused to the insured on the basis of certain principles.